



HAL
open science

DoF of a Cooperative X-Channel with an Application to Distributed Computing

Yue Bi, Philippe Ciblat, Michèle Wigger, Yue Wu

► **To cite this version:**

Yue Bi, Philippe Ciblat, Michèle Wigger, Yue Wu. DoF of a Cooperative X-Channel with an Application to Distributed Computing. IEEE International Symposium on Information Theory (ISIT), Jun 2022, Helsinki, Finland. hal-03700925

HAL Id: hal-03700925

<https://hal.archives-ouvertes.fr/hal-03700925>

Submitted on 21 Jun 2022

HAL is a multi-disciplinary open access archive for the deposit and dissemination of scientific research documents, whether they are published or not. The documents may come from teaching and research institutions in France or abroad, or from public or private research centers.

L'archive ouverte pluridisciplinaire **HAL**, est destinée au dépôt et à la diffusion de documents scientifiques de niveau recherche, publiés ou non, émanant des établissements d'enseignement et de recherche français ou étrangers, des laboratoires publics ou privés.

DoF of a Cooperative X-Channel with an Application to Distributed Computing

Yue Bi^{*†}, Philippe Ciblat^{*}, Michèle Wigger^{*}, Yue Wu[†]

^{*} *LTCI, Telecom Paris, IP Paris, 91120 Palaiseau, France*

{bi, philippe.ciblat, michele.wigger}@telecom-paris.fr

[†]*School of Electronic Information and Electrical Engineering, Shanghai Jiao Tong University, China; wuyue@sjtu.edu.cn*

Abstract—We consider a cooperative X-channel with K transmitters (TXs) and K receivers (RXs) where TXs and RXs are gathered into groups of size r respectively. TXs belonging to the same group cooperate to jointly transmit a message to each of the $K - r$ RXs in all other groups, and each RX individually decodes all its intended messages. By introducing a new interference alignment (IA) scheme, we prove that when K/r is an integer the **Sum Degrees of Freedom (Sum-DoF)** of this channel is lower bounded by $2r$ if $K/r \in \{2, 3\}$ and by $\frac{K(K-r)-r^2}{2K-3r}$ if $K/r \geq 4$. We also prove that the **Sum-DoF** is upper bounded by $\frac{K(K-r)}{2K-3r}$. The proposed IA scheme finds application in a wireless distributed MapReduce framework, where it improves the normalized data delivery time (NDT) compared to the state of the art.

Index Terms—wireless distributed computing, interference alignment, cooperative MIMO

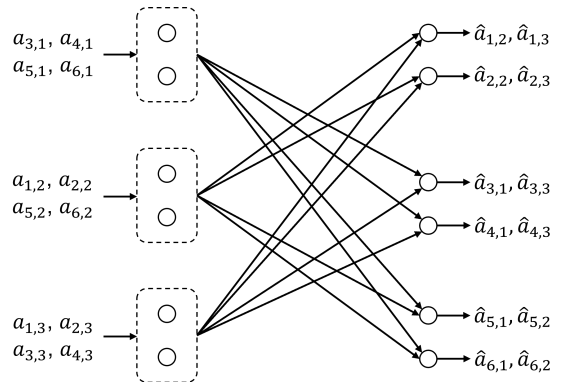

Fig. 1. The cooperative X-channel model for $K = 6, r = 2$

I. INTRODUCTION

Identifying the capacity region of a multi-user channel with interference is generally a difficult task. One way to provide insights on the capacity region is to resort to the *Sum Degrees of Freedom* (Sum-DoF) of the channel, which characterizes the pre-log approximation of the sum-capacity in the asymptotic regime of infinite Signal-to-Noise Ratios (SNR) [1], i.e., when the network operates in the interference-limited regime. The study of the Sum-DoF of interference channels (IC) and X-channels (where each Tx sends a message to each Rx) with and without cooperation has a rich history, see e.g., [2]–[12]. In particular, it has been shown that the Sum-DoF of a fully-connected K -user IC without cooperation is $K/2$ when the channel coefficients are independent and identically distributed (i.i.d.) fading according to a continuous distribution [6] and the Sum-DoF of the corresponding X-channel is $K^2/(2K - 1)$. Both these Sum-DoFs are achieved with interference alignment (IA) [9].

In this paper, we study the Sum-DoF of the partially-connected X-channel in Fig. 1. TXs/RXs are gathered into groups of $r > 0$ consecutive TXs/RXs, and each Rx observes a linear combination of all Tx-signals in Gaussian noise, except for the signals sent by its corresponding Tx-group. TXs in the same group cooperate to jointly transmit a message to each Rx in all other groups, while RXs decode their intended messages independently of each other.

We adapt the IA schemes in [7], [8] to this network model, where we exploit the partial connectivity of the network to reduce the number of precoding matrices and thus the number

of interference spaces. Our proposed scheme achieves Sum-DoF $(K(K - r) - r^2)/(2K - 3r)$ whenever the ratio of K by r is an integer larger than 3. A naive application of the schemes in [7], [8] (without reduction of the number of precoding matrices) would have resulted in the smaller Sum-DoF $(K(K - r))/(2K - 2r)$. Our new lower bound also improves over the $K/2$ lower bound in [9, Theorem 2] which was reported for the special case $r = 1$. In this paper we further show a Sum-DoF upper bound of $K(K - r)/(2K - 3r)$.

The motivation for studying our particular X-channel stems from an application in *MapReduce distributed computing* (DC). MapReduce is a popular framework to carry out heavy computation tasks and runs in three phases [13], [14]. In the first *map phase*, nodes calculate intermediate values (IVA) from their associated input files. In the subsequent *shuffle phase*, nodes exchange these IVAs to obtain all IVAs required to run the final *reduce phase* where they compute the desired output function. The largest part of the execution time in MapReduce systems stems from the IVA *delivery time* during the shuffle phase. Several works proposed to reduce this delivery time through smart coding. More specifically, in wired networks, delivery time is decreased by sending appropriate linear combinations of the IVAs [15]–[17], over wireless cellular networks [18], [19] a similar effect is achieved through simple interference cancellation at the receiving nodes, and over wireless interference networks a gain was achieved by zero-forcing [20]. In this paper, we show further improvement in wireless interference networks using a novel IA scheme.

Notations: We use sans serif font for constants, bold for

vectors and matrices, and calligraphic font for most sets. The sets of complex numbers and positive integers are denoted \mathbb{C} and \mathbb{Z}^+ . For a finite set \mathcal{A} , let $|\mathcal{A}|$ denote its cardinality. For any $n \in \mathbb{Z}^+$, define $[n] \triangleq \{1, 2, \dots, n\}$ and let \mathbf{I}_n be the $n \times n$ identity matrix. Let further $\mathbf{0}$ denote the all-zero matrix and $\mathbf{1}$ the all-one vector, where the dimensions will be clear from the context. For any vector \mathbf{v} , let $\text{diag}(\mathbf{v})$ be the diagonal matrix with diagonal entries given by the elements of the vector \mathbf{v} . When writing $[v_i: i \in \mathcal{S}]$ or $[v_i]_{i \in \mathcal{S}}$ we mean the matrix consisting of the set of columns $\{v_i\}_{i \in \mathcal{S}}$. For two matrices \mathbf{A} and \mathbf{B} , we use $\mathbf{A} \otimes \mathbf{B}$ to denote their Kronecker product.

II. CHANNEL MODEL

Consider an interference network with K TxS and K RxS labeled from 1 to K . For a given group-size $r \geq 1$, where K is assumed divisible by r , we define the group of TxS/RxS

$$\mathcal{T}_k \triangleq \{(k-1)r+1, \dots, kr\}, \quad k \in [\tilde{K}], \quad (1)$$

where $\tilde{K} \triangleq K/r$.

In our network model, each Rx p in Rx-group \mathcal{T}_j observes a linear combination of the signals sent by all TxS *outside* Tx-group \mathcal{T}_j , corrupted by Gaussian noise. Denoting Tx q 's slot- t input by $X_q(t) \in \mathbb{C}$ and Rx p 's slot- t output by $Y_p(t) \in \mathbb{C}$, the input-output relation of the network is:

$$Y_p(t) = \sum_{q \in [K] \setminus \mathcal{T}_j} H_{p,q}(t) X_q(t) + Z_p(t), \quad p \in \mathcal{T}_j, \quad (2)$$

where the sequences of complex-valued channel coefficients $\{H_{p,q}(t)\}$ and standard circularly symmetric Gaussian noises $\{Z_p(t)\}$ are both i.i.d. and independent of each other and of all other channel coefficients and noises. The real and imaginary parts of a coefficient $H_{p,q}(t)$ are i.i.d. according to a given continuous distribution on some bounded interval $[-H_{\max}, H_{\max}]$ and are known by all terminals even before communication starts.

We consider a scenario where all TxS in Tx-group \mathcal{T}_k cooperatively transmit an individual message $a_{p,k}$ to each Rx $p \in [K] \setminus \mathcal{T}_k$ *outside* Rx-group k . When communication is of blocklength T , this message is uniformly distributed over $[2^{\text{TR}_{p,k}}]$, where $R_{p,k} \geq 0$ denotes the rate of transmission, and it is independent of all other messages and of all channel coefficients and noise sequences. As a consequence, Tx $q \in [K]$ produces its block of channel inputs $X_q^{(T)} \triangleq (X_q(1), \dots, X_q(T))$ as

$$X_q^{(T)} = f_q^{(T)} \left(\left\{ a_{p,k} : k = \left\lceil \frac{q}{r} \right\rceil, p \in [K] \setminus \mathcal{T}_k \right\} \right) \quad (3)$$

by means of an encoding function $f_q^{(T)}$ on appropriate domains and so that the inputs satisfy the block-power constraint

$$\frac{1}{T} \sum_{t=1}^T \mathbb{E} [|X_q(t)|^2] \leq P, \quad q \in [K]. \quad (4)$$

Given a power $P > 0$, the *capacity region* $\mathcal{C}(P)$ is defined as the set of all rate tuples $(R_{p,k} : k \in [\tilde{K}], p \in [K] \setminus \mathcal{T}_k)$ so that for each blocklength T there exist encoding functions

$\{f_q^{(T)}\}_{q \in [K]}$ as described above and decoding functions $\{g_{p,k}^{(T)}\}$ on appropriate domains producing the estimates

$$\hat{a}_{p,k} = g_{p,k}^{(T)}(Y_p(1), \dots, Y_p(T)), \quad k \in [\tilde{K}], p \in [K] \setminus \mathcal{T}_k, \quad (5)$$

in a way that the sequence of error probabilities

$$p^{(T)}(\text{error}) \triangleq \Pr \left[\bigcup_{k \in [\tilde{K}]} \bigcup_{p \in [K] \setminus \mathcal{T}_k} \hat{a}_{p,k} \neq a_{p,k} \right] \quad (6)$$

tends to 0 as the blocklength $T \rightarrow \infty$.

Our main interest is in the **Sum-DoF**:

$$\text{Sum-DoF} \triangleq \overline{\lim}_{P \rightarrow \infty} \sup_{\mathbf{R} \in \mathcal{C}(P)} \sum_{k \in [\tilde{K}]} \sum_{p \in [K] \setminus \mathcal{T}_k} \frac{R_{p,k}}{\log P}. \quad (7)$$

III. MAIN RESULTS

The main results of this paper are new upper and lower bounds on the **Sum-DoF** of the network described in the previous Section II. We restrict attention to $K/r > 1$, because for $r = K$ the RxS only observe noise and trivially **Sum-DoF** = 0.

Theorem 1. *When K/r is an integer strictly larger than 1, the **Sum-DoF** of the network in Section II is lower bounded as:*

$$\text{Sum-DoF} \geq \text{Sum-DoF}_{\text{Lb}} \triangleq \begin{cases} 2r & \text{if } K/r \in \{2, 3\}, \\ \frac{K(K-r)-r^2}{2K-3r} & \text{if } K/r \geq 4, \end{cases} \quad (8)$$

and upper bounded as:

$$\text{Sum-DoF} \leq \frac{K(K-r)}{2K-3r}. \quad (9)$$

Proof: See Section V for the proof of the lower bound and [21, Appendix A] for the proof of the upper bound. ■

For $K/r \in \{2, 3\}$ the bounds (8) and (9) match and yield:

Corollary 1. *For $K/r \in \{2, 3\}$, we have **Sum-DoF** = $2r$.*

For $r = 1$, our lower bound (8) improves over the lower bound **Sum-DoF** $\geq K/2$ reported in [9] for all values of K .

Remark 1. *By the symmetry of the setup and standard time-sharing arguments, the bound in (8) implies the following bound on the Per-Message DoF (PMDoF)*

$$\text{PMDoF} \triangleq \lim_{P \rightarrow \infty} \sup_{\mathbf{R} \in \mathcal{C}(P)} \min_{\substack{k \in [K] \\ p \in [K] \setminus \mathcal{T}_k}} \frac{R_{p,k}}{\log P} \geq \frac{\text{Sum-DoF}_{\text{Lb}}}{K(K/r-1)}. \quad (10)$$

IV. APPLICATION TO WIRELESS DISTRIBUTED COMPUTING

A. The MapReduce System

Consider a distributed computing (DC) system with K nodes labelled $1, \dots, K$; N input files W_1, \dots, W_N ; and Q output functions h_1, \dots, h_Q mapping the input files to the desired computations. A *Map-Reduce* System decomposes the functions h_1, \dots, h_Q as

$$h_q(W_1, \dots, W_N) = \phi_q(a_{q,1}, \dots, a_{q,N}), \quad q \in [Q], \quad (11)$$

where ϕ_q is an appropriate *reduce function* and $a_{q,i}$ is an *intermediate value (IVA)* calculated from input file W_i through an appropriate *map function*:

$$a_{q,i} = \psi_{q,i}(W_i), \quad i \in [N]. \quad (12)$$

For simplicity, all IVAs are assumed independent and consisting of A i.i.d. bits.

Computations are performed in 3 phases:

Map phase: A subset of all input files $\mathcal{M}_p \subseteq [N]$ is assigned to each node $p \in [K]$. Node p computes all IVAs $\{a_{q,i} : i \in \mathcal{M}_p, q \in [Q]\}$ associated with these input files.

Shuffle phase: Computations of the Q output functions is assigned to the K nodes, where we denote by $\mathcal{Q}_p \subseteq [Q]$ the output functions assigned to node p .

The K nodes in the system communicate over T uses of a wireless network in a full-duplex mode, where T is a design parameter. During this communication, nodes communicate IVAs that they calculated in the Map phase to nodes that are missing these IVAs for the computations of their assigned output functions. So, node $p \in [K]$ produces complex channel inputs of the form

$$X_p^{(T)} \triangleq (X_p(1), \dots, X_p(T)) = f_p^{(T)}(\{a_{1,i}, \dots, a_{Q,i}\}_{i \in \mathcal{M}_p}), \quad (13)$$

by means of appropriate encoding function $f_p^{(T)}$ satisfying the power constraint (4). Given the full-duplex nature of the network, Node p also observes the complex channel outputs

$$Y_p(t) = \sum_{\ell \in [K]} H_{p,\ell}(t)X_\ell(t) + Z_p(t), \quad t \in [T], \quad (14)$$

where noises $\{Z_p(t)\}$ and channel coefficients $\{H_{p,\ell}(t)\}$ are as defined in Section II.

Based on its outputs $Y_p^{(T)} \triangleq (Y_p(1), \dots, Y_p(T))$ and the IVAs $\{a_{q,i} : i \in \mathcal{M}_p, q \in [Q]\}$ it computed during the Map phase, Node p decodes the missing IVAs $\{a_{q,i} : i \notin \mathcal{M}_p, q \in \mathcal{Q}_p\}$ required to compute its assigned output functions $\{h_q\}_{q \in \mathcal{Q}_p}$ as:

$$\hat{a}_{q,i} = g_{q,i}^{(T)}(\{a_{1,i}, \dots, a_{Q,i}\}_{i \in \mathcal{M}_p}, Y_p^{(T)}), \quad i \notin \mathcal{M}_p, q \in \mathcal{Q}_p. \quad (15)$$

Reduce phase: Each node applies the reduce functions to the appropriate IVAs calculated during the Map phase or decoded in the Shuffle phase.

The performance of the distributed computing system is measured in terms of its *computation load*

$$r \triangleq \sum_{p \in [K]} \frac{|\mathcal{M}_p|}{N}, \quad (16)$$

and the *normalized delivery time (NDT)*

$$\Delta = \lim_{P \rightarrow \infty} \lim_{A \rightarrow \infty} \frac{T}{A \cdot Q \cdot N} \cdot \log P. \quad (17)$$

We focus on the *fundamental NDT-computation tradeoff* $\Delta^*(r)$, which is defined as the infimum over all values of Δ satisfying (17) for some choice of file assignments $\{\mathcal{M}_p\}$, transmission time T , and encoding and decoding functions $\{f_p^{(T)}\}$ and $\{g_{q,i}^{(T)}\}$ in (13) and (15), all depending on A so that the probability IVA decoding error

$$\Pr \left[\bigcup_{p \in [K]} \bigcup_{q \in \mathcal{Q}_p} \bigcup_{i \notin \mathcal{M}_p} \hat{a}_{q,i} \neq a_{q,i} \right] \rightarrow 0 \quad \text{as } A \rightarrow \infty. \quad (18)$$

B. Results on Normalized Delivery Time

Theorem 2. Assume N and Q are both multiples of K . If N is large enough, the fundamental NDT-computation tradeoff of the full-duplex wireless DC system is upper bounded as

$$\Delta^*(r) \leq \text{lowc} \left((K, 0) \cup \left\{ \left(r, \frac{1-r/K}{\text{Sum-DoF}_{\text{LB}}} \right) : 1 \leq r < K \text{ and } r|K \right\} \right), \quad (19)$$

where $\text{lowc}(\cdot)$ denotes the lower-convex envelope, $\text{Sum-DoF}_{\text{LB}}$ is defined in Eq. (8), and $r|K$ indicates that r divides K .

Proof: We prove the result for integer values of $r \in [K]$ that divide K . The final result follows by time- and memory-sharing arguments when N is sufficiently large.

We reuse the group definition in \mathcal{T}_k in (1).

Map phase: Choose the same file assignment for all nodes in group \mathcal{T}_k :

$$\mathcal{M}_p = \tilde{\mathcal{M}}_k \triangleq \left\{ (k-1)\frac{rN}{K} + 1, \dots, k\frac{rN}{K} \right\}, \quad p \in \mathcal{T}_k, k \in [\tilde{K}], \quad (20)$$

This file assignment satisfies the communication load r in (16).

Shuffle phase: We assume the output function assignment is given as:

$$\mathcal{Q}_p \triangleq \{(p-1)Q/K + 1, \dots, pQ/K\}, \quad p \in [K]. \quad (21)$$

The shuffle phase is split into rounds, where in each round, each group of nodes \mathcal{T}_k communicates a different IVA $a_{\nu,i}$ to each node $\ell \in [K] \setminus \mathcal{T}_k$, for chosen $\nu \in \mathcal{Q}_\ell$ and $i \in \tilde{\mathcal{M}}_k$. To send all missing IVAs, $\Phi \triangleq |\mathcal{Q}_1| \cdot |\tilde{\mathcal{M}}_1| = (Q/K) \cdot (Nr/K)$ rounds are necessary.

Choose a blocklength T' and each node chooses an encoding function $\{f_p^{(T')}\}_{T'}$ achieving symmetric rates $(R_{p,k} = R(P), k \in [\tilde{K}], p \in [K] \setminus \mathcal{T}_k)$ according to the setup of Section II to encode the IVAs transmitted in a round. The rate $R(P)$ satisfies $\lim_{P \rightarrow \infty} \frac{R(P)}{\log P} = \frac{\text{Sum-DoF}_{\text{LB}}}{K(K/r-1)}$ and T' is chosen such that

$$\frac{A}{T'} < R(P). \quad (22)$$

Since all nodes in a group \mathcal{T}_k compute the same IVAs in the Map phase, they can compute each others' inputs. With its channel outputs in a round, each Node $p \in \mathcal{T}_k$ thus forms:

$$\tilde{Y}_p(t) \triangleq Y_p(t) - \sum_{\ell \in \mathcal{T}_k} H_{p,\ell}(t)X_\ell(t), \quad p \in \mathcal{T}_k, t \in [T'], \quad (23)$$

and it applies the decoding functions $\{g_{p,k}^{(T')}\}_{k \in [\tilde{K}] \setminus [p/r]}$ corresponding to $\{f_p^{(T')}\}$ to the sequence $\tilde{Y}_p(1), \dots, \tilde{Y}_p(T')$ to reconstruct the IVAs sent to it in this round.

Analysis: By our choice of the coding scheme and (22), the probability of error in (18) tends to 0 as $T' \rightarrow \infty$. By (10), (22) and since the total length of the shuffle phase is $T \triangleq \Phi T'$, the NDT of our scheme is:

$$\lim_{P \rightarrow \infty} \lim_{A \rightarrow \infty} \frac{T \log P}{A \cdot Q \cdot N} = \lim_{P \rightarrow \infty} \lim_{A \rightarrow \infty} \frac{\Phi T' \log P}{A \cdot Q \cdot N}$$

$$\geq \lim_{P \rightarrow \infty} \frac{r \log P}{K^2 R(P)} = \frac{1 - \frac{r}{\tilde{K}}}{\text{Sum-DoF}_{\text{Lb}}} \quad (24)$$

This proves the desired achievability result. \blacksquare

The one-shot scheme in [20], which applies zero-forcing and side information cancellation, achieves the upper bound

$$\Delta^*(r) \leq \text{lowc} \left(\left\{ \left(r, \frac{1 - r/K}{\min(K, 2r)} \right) : 1 \leq r \leq K \right\} \right). \quad (25)$$

For fixed K and for r a value that divides K but neither equals $K/2$ nor $K/3$, our new upper bound in (19) is strictly better (lower) than the upper bound in (25). If K is even, the two bounds coincide on the interval $r \in [K/2, K]$, where they are given by the straight line $(1 - r/K)/K$. If K is a multiple of 3, the two bounds also coincide for $r = K/3$, where they are given by $(1 - r/K)/r$. For other values of r , the bound in (25) can be smaller. An improved upper bound on $\Delta^*(r)$ is thus obtained by combining the two upper bounds, which results in the lower-convex envelope of the union of the sets in (19) and (25).

In Fig. 2, we numerically compare the bounds in (19) and (25) for $K = 12$. We observe that on the interval $r \in [0, 4]$ the bound in (19) performs better and on the interval $r \in [4, 6]$ the bound (25) performs better because (19) is simply given by a straight line as $r = 5$ does not divide 12. On the interval $r \in [6, 12]$ both bounds perform equally-well as explained in the previous paragraph.

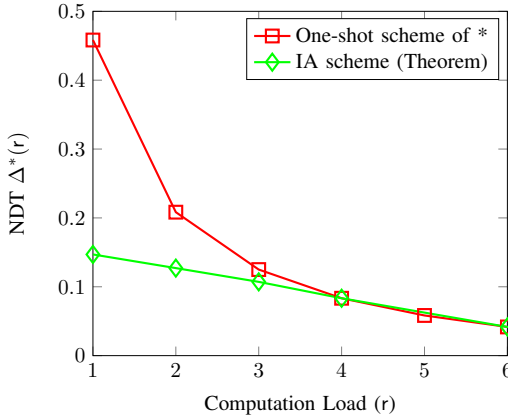

Fig. 2. Upper bounds on $\Delta^*(r)$ for the one-shot scheme in * and our IA scheme when $K = 12$.

V. PROOF OF THE Sum-DoF LOWER BOUND IN THEOREM 1

For $\tilde{K} \in \{2, 3\}$ the proof follows easily by ignoring all TxS, RxS, and messages outside groups \mathcal{T}_1 and \mathcal{T}_2 . For details see [21, Section V.A]. We thus focus on the case $\tilde{K} = 4$.

1) *Coding Scheme*: We fix a parameter $\eta \in \mathbb{Z}^+$, define

$$\Gamma \triangleq K \cdot (K - 2) \cdot r^2, \quad (26)$$

and choose $T = \eta^\Gamma (\tilde{K} - 2) + (\eta + 1)^\Gamma (\tilde{K} - 1)$. Each message $\{a_{p,k}\}$ for $k \in [\tilde{K}]$, $p \in [K] \setminus \mathcal{T}_k$ —but not messages $\{a_{p,\tilde{K}}\}_{p \in \mathcal{T}_1}$ which are not transmitted in our coding scheme—is encoded using a circularly symmetric Gaussian codebook of average

power $P/(K - r)$ and codeword length η^Γ . Each codeword is sent over a block of T consecutive channel uses. More precisely, let $\{\mathbf{b}_{p,k}\}$ be the η^Γ -length codeword for message $a_{p,k}$. For $j \in [K]$, $k \in [\tilde{K}] \setminus \{j\}$ and $(j, k) \neq (1, \tilde{K})$ define $\tilde{\mathbf{b}}_{j,k} \triangleq (\mathbf{b}_{(j-1)r+1,k}^T, \mathbf{b}_{(j-1)r+2,k}^T, \dots, \mathbf{b}_{j \cdot r,k}^T)^T$ where the superscript T stands for the transpose operator. Form also the T -length vector of channel inputs $\mathbf{X}_q \triangleq (X_q(1), \dots, X_q(T))^T$ for each Tx q , and $\tilde{\mathbf{X}}^{(k)} \triangleq (\mathbf{X}_{(k-1)r+1}^T, \dots, \mathbf{X}_{kr}^T)^T$ for each Tx-group k . Tx-groups form their inputs as:

$$\tilde{\mathbf{X}}^{(1)} = \sum_{i=2}^{\tilde{K}} \tilde{\mathbf{V}}^{(i,1)} \tilde{\mathbf{U}}_i \tilde{\mathbf{b}}_{i,1}, \quad (27)$$

$$\tilde{\mathbf{X}}^{(k)} = \sum_{i \in [\tilde{K}] \setminus \{1,k\}} \tilde{\mathbf{V}}^{(i,k)} \tilde{\mathbf{U}}_i \tilde{\mathbf{b}}_{i,k} + \tilde{\mathbf{V}}^{(1,k)} \tilde{\mathbf{U}}_k \tilde{\mathbf{b}}_{1,k}, \quad k \in [\tilde{K} - 1] \setminus \{1\}, \quad (28)$$

$$\tilde{\mathbf{X}}^{(\tilde{K})} = \sum_{i \in \{2, \dots, \tilde{K}-1\}} \tilde{\mathbf{V}}^{(i,\tilde{K})} \tilde{\mathbf{U}}_i \tilde{\mathbf{b}}_{i,\tilde{K}}, \quad (29)$$

where

$$\tilde{\mathbf{U}}_i \triangleq \mathbf{I}_{\text{d}_r} \otimes \mathbf{U}_i, \quad i \in \{2, 3, \dots, \tilde{K}\}, \quad (30)$$

and matrices $\{\mathbf{U}_i\}$ and $\{\mathbf{V}^{(i,k)}\}$ are described shortly.

Notice that for $i \in \{2, 3, \dots, \tilde{K}\}$, messages $\{\tilde{\mathbf{a}}_{i,k}\}_{k \in [\tilde{K}] \setminus \{i\}}$ and $\tilde{\mathbf{a}}_{i,i}$ are multiplied by the same precoding matrix $\tilde{\mathbf{U}}_i$.

2) *Zero-forcing Matrices* $\{\tilde{\mathbf{V}}^{(i,k)}\}$: For each $i, k \in [\tilde{K}]$ with $i \neq k$, construct the $T \times T$ diagonal matrices $\mathbf{S}_1^{(i,k)}, \dots, \mathbf{S}_r^{(i,k)}$ by picking the real and imaginary parts of all non-zero entries i.i.d. according to a continuous distribution over $[-H_{\max}, H_{\max}]$ and form the diagonal matrix

$$\mathbf{S}^{(i,k)} \triangleq \text{diag}(\mathbf{S}_1^{(i,k)}, \dots, \mathbf{S}_r^{(i,k)}). \quad (31)$$

Define the $rT \times rT$ channel matrix from Tx-group k to Rx-group j :

$$\tilde{\mathbf{H}}^{(j,k)} \triangleq \begin{pmatrix} \mathbf{H}_{(j-1) \cdot r+1, (k-1) \cdot r+1} & \cdots & \mathbf{H}_{(j-1) \cdot r+1, k \cdot r} \\ \vdots & & \vdots \\ \mathbf{H}_{j \cdot r, (k-1) \cdot r+1} & \cdots & \mathbf{H}_{j \cdot r, k \cdot r} \end{pmatrix} \quad (32)$$

where $\mathbf{H}_{p,q} \triangleq \text{diag}([H_{p,q}(1), H_{p,q}(2), \dots, H_{p,q}(T)])$.

Choose the precoding matrices as:¹

$$\tilde{\mathbf{V}}^{(i,k)} = \left(\tilde{\mathbf{H}}^{(i,k)} \right)^{-1} \mathbf{S}^{(i,k)}, \quad i, k \in [\tilde{K}], i \neq k, \quad (33)$$

so that all information sent to any Rx in group \mathcal{T}_j is zero-forced at all other RxS in the same group \mathcal{T}_j . Defining for each triple $(i, j, k) \in [\tilde{K}]^3$ with $i \neq j, j \neq k, k \neq i$ the “generalized” channel matrix

$$\tilde{\mathbf{G}}_j^{(i,k)} = \begin{pmatrix} \mathbf{G}_{(j-1) \cdot r+1}^{((i-1) \cdot r+1, k)} & \cdots & \mathbf{G}_{(j-1) \cdot r+1}^{(i \cdot r, k)} \\ \vdots & & \vdots \\ \mathbf{G}_{j \cdot r}^{((i-1) \cdot r+1, k)} & \cdots & \mathbf{G}_{j \cdot r}^{(i \cdot r, k)} \end{pmatrix} \quad (34)$$

$$\triangleq \tilde{\mathbf{H}}^{(j,k)} \cdot \tilde{\mathbf{V}}^{(i,k)} = \tilde{\mathbf{H}}^{(j,k)} \left(\tilde{\mathbf{H}}^{(i,k)} \right)^{-1} \mathbf{S}^{(i,k)}, \quad (35)$$

¹We assume that all matrices $\{\tilde{\mathbf{H}}^{(i,k)}\}$ are invertible, which happens with probability 1. Otherwise, TxS and RxS immediately declare an error in the communication.

allows to write the signals at the various Rx-groups as:

$$\tilde{\mathbf{Y}}^{(1)} = \underbrace{\sum_{k=2}^{\tilde{K}-1} \mathbf{S}^{(1,k)} \tilde{\mathbf{U}}_k \tilde{\mathbf{b}}_{1,k}}_{\text{desired signal}} + \sum_{i=2}^{\tilde{K}} \sum_{k \notin \{1,i\}} \tilde{\mathbf{G}}_1^{(i,k)} \tilde{\mathbf{U}}_i \tilde{\mathbf{b}}_{i,k} + \tilde{\mathbf{Z}}^{(1)}, \quad (36)$$

$$\begin{aligned} \tilde{\mathbf{Y}}^{(j)} &= \underbrace{\sum_{k \neq j} \mathbf{S}^{(j,k)} \tilde{\mathbf{U}}_j \tilde{\mathbf{b}}_{j,k}}_{\text{desired signal}} + \sum_{i \notin \{1,j\}} \sum_{k \notin \{i,j\}} \tilde{\mathbf{G}}_j^{(i,k)} \tilde{\mathbf{U}}_i \tilde{\mathbf{b}}_{i,k} \\ &+ \sum_{k \notin \{1,j,\tilde{K}\}} \tilde{\mathbf{G}}_j^{(1,k)} \tilde{\mathbf{U}}_k \tilde{\mathbf{b}}_{1,k} + \tilde{\mathbf{Z}}^{(j)}, \quad j \in [\tilde{K}] \setminus \{1\}. \end{aligned} \quad (37)$$

Here $\tilde{\mathbf{Z}}^{(j)}$ are the corresponding Gaussian noise vectors observed at Rx-group j , for $j \in [\tilde{K}]$.

3) *IA Matrices* $\{\mathbf{U}_i\}$: Inspired by the IA scheme in [6], we choose each $\mathbb{T} \times \eta^\Gamma$ precoding matrix \mathbf{U}_i so that its column-span includes all power products (with powers from 1 to η) of the “generalized” channel matrices $\mathbf{G}_{p'}^{(p,k)}$ that premultiply \mathbf{U}_i in (36) and (37). That means for $i \in [\tilde{K}] \setminus \{1\}$:

$$\mathbf{U}_i = \left[\prod_{\mathbf{G} \in \mathcal{G}_i} \mathbf{G}^{\alpha_i, \mathbf{G}} \cdot \boldsymbol{\Xi}_i : \forall \alpha_i \in [\eta]^\Gamma \right], \quad (38)$$

where $\{\boldsymbol{\Xi}_i\}_{i=2}^{\tilde{K}}$ are i.i.d. random vectors independent of all channel matrices, noises, and messages, and

$$\begin{aligned} \mathcal{G}_i &\triangleq \left\{ \mathbf{G}_{p'}^{(p,k)} : p \in \mathcal{T}_i, k \in [\tilde{K}] \setminus \mathcal{T}_i, p' \in [\mathbb{K}] \setminus (\mathcal{T}_i \cup \mathcal{T}_k) \right\} \\ &\cup \left\{ \mathbf{G}_{p'}^{(p,i)} : p \in \mathcal{T}_1, p' \in [\mathbb{K}] \setminus \{\mathcal{T}_i \cup \mathcal{T}_1\} \right\}, \end{aligned} \quad (39)$$

and $\alpha_i \triangleq (\alpha_{i, \mathbf{G}} : \mathbf{G} \in \mathcal{G}_i)$.

4) *Analysis of Signal-and-Interference Subspaces*: Since the column-span of \mathbf{U}_i contains all power products of powers 1 to η of the modified channel matrices $\mathbf{G} \in \mathcal{G}_i$ that premultiply \mathbf{U}_i in (36) and (37), the product of any of these matrices with \mathbf{U}_i is included in the column-space of the $\mathbb{T} \times \eta^\Gamma$ -matrix

$$\begin{aligned} \mathbf{W}_i &= \left[\prod_{\mathbf{G} \in \mathcal{G}_i} \mathbf{G}^{\alpha_i, \mathbf{G}} \cdot \boldsymbol{\Xi}_i : \forall \alpha_i \in [\eta + 1]^\Gamma \right], \\ &\text{for } i \in [\tilde{K}] \setminus \{1\}, \end{aligned} \quad (40)$$

where notice that $|\mathcal{G}_i| = \Gamma$. Formally, for each $i \in \{2, 3, \dots, \tilde{K}\}$ and $\mathbf{G} \in \mathcal{G}_i$, we have $\text{span}(\mathbf{G} \cdot \mathbf{U}_i) \subseteq \text{span}(\mathbf{W}_i)$. As a consequence, the signal and interference space at a Rx $p \in \mathcal{T}_j$, for $j \in \{2, \dots, \tilde{K}\}$, is represented by the matrix:

$$\Lambda_p \triangleq \left[\underbrace{\mathbf{D}_p}_{\text{signal space}}, \underbrace{\mathbf{W}_2, \dots, \mathbf{W}_{j-1}, \mathbf{W}_{j+1}, \dots, \mathbf{W}_{\tilde{K}}}_{\text{interference space}} \right]. \quad (41)$$

with the signal subspaces given by the $\mathbb{T} \times (\tilde{K}-1)\eta^\Gamma$ -matrices

$$\mathbf{D}_p \triangleq \left[\mathbf{S}_{p \bmod r}^{(j,k)} \cdot \mathbf{U}_j \right]_{k \in [\tilde{K}] \setminus \{j\}}, \quad p \in \mathcal{T}_j. \quad (42)$$

For a Rx p in the first group \mathcal{T}_1 , the signal and interference spaces are represented by the $\mathbb{T} \times \mathbb{T}$ -matrix:

$$\Lambda_p = \left[\underbrace{\mathbf{D}_{p,2}, \dots, \mathbf{D}_{p,\tilde{K}-1}}_{\text{signal space}}, \underbrace{\mathbf{W}_2, \mathbf{W}_3, \dots, \mathbf{W}_{\tilde{K}}}_{\text{interference space}} \right], \quad (43)$$

where the signal subspace is given by the $\mathbb{T} \times \eta^\Gamma$ -matrices

$$\mathbf{D}_{p,k} \triangleq \mathbf{S}_p^{(1,k)} \cdot \mathbf{U}_k, \quad k \in \{2, \dots, \tilde{K}-1\}, \quad p \in \mathcal{T}_1.$$

We shall prove that all matrices $\{\Lambda_p\}$ are of full column rank. This proves that the desired signals intended for Rx p can be separated from each other and from the interference space at this Rx. In the limits $\eta \rightarrow \infty$ (and thus $\mathbb{T} \rightarrow \infty$) and $\mathbb{P} \rightarrow \infty$, this establishes an DoF of $\lim_{\eta \rightarrow \infty} \frac{(\tilde{K}-1)\eta^\Gamma}{\mathbb{T}} = \frac{\tilde{K}-1}{2\tilde{K}-3}$ at Rxs $p \in [\mathbb{K}] \setminus \mathcal{T}_1$ and an DoF of $\frac{\tilde{K}-2}{2\tilde{K}-3}$ for Rxs $p \in \mathcal{T}_1$. The **Sum-DoF** of the entire system is thus given by **Sum-DoF_{LB}**, which establishes the desired achievability result.

Notice that each matrix Λ_p , for $p \in [\mathbb{K}]$, is of the form of the matrix Λ in Lemma 1 at the end of this section. Defining the matrices $\{\hat{\mathbf{U}}_i\}$, $\{\hat{\mathbf{W}}_i\}$, $\{\hat{\mathbf{D}}_p\}$ and $\{\hat{\mathbf{D}}_{p,k}\}$ in the same way as $\{\mathbf{U}_i\}$, $\{\mathbf{W}_i\}$, $\{\mathbf{D}_p\}$, and $\{\mathbf{D}_{p,k}\}$ but with $\boldsymbol{\Xi}_i$ replaced by the all-one vector $\mathbf{1}$, it suffices to show that with probability 1 all square submatrices of the following matrices (which play the roles of $\{\mathbf{B}_i\}$ when applying Lemma 1) are full rank:

$$\{\hat{\mathbf{D}}_p\}_{p \in [\tilde{K}] \setminus \mathcal{T}_1}, \quad \{\hat{\mathbf{W}}_j\}_{j=2}^{\tilde{K}}, \quad \left\{ \left[\hat{\mathbf{D}}_{p,j}, \hat{\mathbf{W}}_j \right] \right\}_{\substack{p \in \mathcal{T}_1 \\ j \in \{2, \dots, \tilde{K}\}}}. \quad (44)$$

For matrix $\hat{\mathbf{D}}_p$, $p \in \mathcal{T}_2$, this proof is provided in [21, Appendix B]. For the other matrices the proof is similar.

Lemma 1. Consider positive integers $n_1, n_2, \dots, n_{\tilde{K}}$ summing to $C \triangleq \sum_{i=1}^{\tilde{K}} n_i \leq \mathbb{T}$, and for each $i \in [\tilde{K}]$ and $k \in [n_i]$ a diagonal $\mathbb{T} \times \mathbb{T}$ matrix $\mathbf{B}_{i,k} \in \mathbb{C}$ so that all square submatrices of the following matrices are full rank:

$$\mathbf{B}_i \triangleq [\mathbf{B}_{i,1} \cdot \mathbf{1}, \mathbf{B}_{i,2} \cdot \mathbf{1}, \dots, \mathbf{B}_{i,n_i} \cdot \mathbf{1}], \quad i \in [\tilde{K}]. \quad (45)$$

Let $\{\boldsymbol{\Xi}_i\}$ be independent \mathbb{T} -length vectors with i.i.d. entries from continuous distributions and define the $\mathbb{T} \times n_i$ -matrices

$$\mathbf{A}_i \triangleq [\mathbf{B}_{i,1} \cdot \boldsymbol{\Xi}_i, \mathbf{B}_{i,2} \cdot \boldsymbol{\Xi}_i, \dots, \mathbf{B}_{i,n_i} \cdot \boldsymbol{\Xi}_i], \quad i \in [\tilde{K}]. \quad (46)$$

Then, the $\mathbb{T} \times C$ -matrix $\Lambda \triangleq [\mathbf{A}_1, \mathbf{A}_2, \dots, \mathbf{A}_{\tilde{K}}]$ has full column rank with probability 1.

Proof: See [21]. ■

VI. CONCLUSION

We provided new lower and upper bounds on the **Sum-DoF** of a particular partially-connected K-user X-channel where each group of r consecutive TxS cooperates and sends a message to each Rx outside its group. When $K/r \in \{2, 3\}$ the bounds coincide and establish the exact **Sum-DoF** of the system. The proposed lower bound is used to provide an improved NDT for wireless distributed Map-Reduce systems.

ACKNOWLEDGEMENT

This work has been supported by the European Research Council (ERC) under the European Union’s Horizon 2020 under grant agreement No 715111, and in part by National Key R&D Program of China under Grant No 2020YFB1807504 and National Science Foundation of China Key Project under Grant No 61831007.

REFERENCES

- [1] P. Algoet and J. Cioffi, "The capacity of a channel with Gaussian noise and intersymbol interference," in *IEEE International Symposium on Information Theory*, Budapest, Hungary, Jun. 1991, p. 16.
- [2] G. J. Foschini and M. J. Gans, "On limits of wireless communications in a fading environment when using multiple antennas," *Wireless Personal Communications*, vol. 6, no. 3, pp. 311–335, Mar. 1998.
- [3] A. Lapidoth, S. Shamai, and M. Wigger, "On cognitive interference networks," in *IEEE Information Theory Workshop*, Tahoe City, CA, USA, Sep. 2007, pp. 325–330.
- [4] N. Devroye and M. Sharif, "The multiplexing gain of MIMO X-channels with partial transmit side-information," in *IEEE International Symposium on Information Theory*, Nice, France, Jun. 2007, pp. 111–115.
- [5] V. R. Cadambe and S. A. Jafar, "Interference alignment and degrees of freedom of the K-user interference channel," *IEEE Transactions on Information Theory*, vol. 54, no. 8, pp. 3425–3441, Aug. 2008.
- [6] S. Jafar and S. Shamai, "Degrees of freedom region of the MIMO X-channel," *IEEE Transactions on Information Theory*, vol. 54, no. 1, pp. 151–170, Jan. 2008.
- [7] V. R. Cadambe and S. A. Jafar, "Interference alignment and the degrees of freedom of wireless X networks," *IEEE Transactions on Information Theory*, vol. 55, no. 9, pp. 3893–3908, Sep. 2009.
- [8] V. S. Annapureddy, A. El Gamal, and V. V. Veeravalli, "Degrees of freedom of interference channels with CoMP transmission and reception," *IEEE Transactions on Information Theory*, vol. 58, no. 9, pp. 5740–5760, Sep. 2012.
- [9] V. R. Cadambe and S. A. Jafar, "Can feedback, cooperation, relays and full duplex operation increase the degrees of freedom of wireless networks?" in *IEEE International Symposium on Information Theory*, Toronto, Canada, Jul. 2008, pp. 1263–1267.
- [10] A. S. Motahari, S. Oveis-Gharan, M.-A. Maddah-Ali, and A. K. Khandani, "Real interference alignment: Exploiting the potential of single antenna systems," *IEEE Transactions on Information Theory*, vol. 60, no. 8, pp. 4799–4810, Aug. 2014.
- [11] M. Zamanighomi and Z. Wang, "Degrees of freedom region of wireless X networks based on real interference alignment," *IEEE Transactions on Information Theory*, vol. 62, no. 4, pp. 1931–1941, Apr. 2016.
- [12] Y. Wei and T. Lok, "An iterative interference alignment algorithm for the general MIMO X channel," *IEEE Transactions on Wireless Communications*, vol. 18, no. 3, pp. 1847–1859, Mar. 2019.
- [13] J. S. Ng, W. Y. B. Lim, N. C. Luong, Z. Xiong, A. Asheralieva, D. Niyato, C. Leung, and C. Miao, "A comprehensive survey on coded distributed computing: Fundamentals, challenges, and networking applications," *IEEE Communications Surveys & Tutorials*, vol. 23, no. 3, pp. 1800–1837, Jun. 2021.
- [14] J. Dean and S. Ghemawat, "MapReduce: simplified data processing on large clusters," *Communications of the ACM*, vol. 51, no. 1, pp. 107–113, Jan. 2008.
- [15] S. Li, M. A. Maddah-Ali, Q. Yu, and A. S. Avestimehr, "A fundamental tradeoff between computation and communication in distributed computing," *IEEE Transactions on Information Theory*, vol. 64, no. 1, pp. 109–128, Jan. 2018.
- [16] Q. Yan, S. Yang, and M. Wigger, "Storage-computation-communication tradeoff in distributed computing: Fundamental limits and complexity," *IEEE Transactions on Information Theory*, pp. 1–1, 2022.
- [17] F. Xu, S. Shao, and M. Tao, "New results on the computation-communication tradeoff for heterogeneous coded distributed computing," *IEEE Transactions on Communications*, vol. 69, no. 4, pp. 2254–2270, Apr. 2021.
- [18] S. Li, Q. Yu, M. A. Maddah-Ali, and A. S. Avestimehr, "A scalable framework for wireless distributed computing," *IEEE/ACM Transactions on Networking*, vol. 25, no. 5, pp. 2643–2654, Oct. 2017.
- [19] K. Yang, Y. Shi, and Z. Ding, "Data shuffling in wireless distributed computing via low-rank optimization," *IEEE Transactions on Signal Processing*, vol. 67, no. 12, pp. 3087–3099, Jun. 2019.
- [20] F. Li, J. Chen, and Z. Wang, "Wireless mapreduce distributed computing," *IEEE Transactions on Information Theory*, vol. 65, no. 10, pp. 6101–6114, Oct. 2019.
- [21] Y. Bi, M. Wigger, P. Ciblat, and Y. Wu, "Dof of a cooperative x-channel with an application to distributed computing," 2022, arXiv: 2201.11149 [cs.IT].