



HAL
open science

Double synchronous controller for integration of large-scale renewable energy sources into a low-inertia power grid

Edris Pouresmaeil, Majid Mehrasa, Radu Godina, Ionel Vechiu, Rubén L Rodríguez, João Catalão

► **To cite this version:**

Edris Pouresmaeil, Majid Mehrasa, Radu Godina, Ionel Vechiu, Rubén L Rodríguez, et al.. Double synchronous controller for integration of large-scale renewable energy sources into a low-inertia power grid. 2017 IEEE PES Innovative Smart Grid Technologies Conference Europe (ISGT-Europe), Sep 2017, Torino, Italy. hal-01940013

HAL Id: hal-01940013

<https://hal.science/hal-01940013>

Submitted on 29 Nov 2018

HAL is a multi-disciplinary open access archive for the deposit and dissemination of scientific research documents, whether they are published or not. The documents may come from teaching and research institutions in France or abroad, or from public or private research centers.

L'archive ouverte pluridisciplinaire **HAL**, est destinée au dépôt et à la diffusion de documents scientifiques de niveau recherche, publiés ou non, émanant des établissements d'enseignement et de recherche français ou étrangers, des laboratoires publics ou privés.

Double Synchronous Controller for Integration of Large-Scale Renewable Energy Sources into a Low-Inertia Power Grid

Edris Pouresmaeil
ESTIA Institute of Technology,
France, and INESC-ID/
IST-UL, Portugal

Majid Mehrasa and
Radu Godina
C-MAST/UBI,
Portugal

Ionel Vechiu and
Rubén L. Rodríguez
ESTIA Institute of
Technology, France

João P. S. Catalão
INESC TEC and FEUP,
C-MAST/UBI, and
INESC-ID/IST-UL, Portugal

Abstract—Renewable energy sources are normally connected to the power grid via power electronic converters. High penetration of these energy sources into the power grid leads to high instability in voltage and frequency. This issue is caused by neglecting the inherent characteristics of synchronous generators i.e., inertia, damping and proper active and reactive power sharing in the structure of the used control technique in the control loop of the interfaced converter between power grid and renewable energy sources. This paper presents a power-based control technique based on a double synchronous controller (DSC) for interfaced converter between the renewable energy sources and the power grid, including an active-reactive power based dynamic equation. Through the proposed DSC, a decoupled control method is performed in which both active and reactive power can be injected from renewable energy sources into the power grid by the interfaced power converter with the inherent features of synchronous power generators. By using the proposed control technique, a stable operation of the power grid can be guaranteed during the integration of large-scale renewable energy sources. Stringent simulation results performed in MATLAB/SIMULINK environment verify the proficiency of the proposed control technique.

Index Terms—Large-scale renewable energy sources, double synchronous controller (DSC), active and reactive power.

I. INTRODUCTION

Because of environmental reasons and also the lack of fossil fuel sources in the near future, using power converter based distributed generation (DG) sources [1] in the frame of microgrid systems has attracted significant attention in recent years [2]-[3].

However, increasing the penetration of renewable energy sources in power grids by use power electronic converters leads to major problems, e.g. power flow fluctuations, unstable operation, oscillations of system frequency and out-of-range of converter capability curve, which have been presented recently in several papers [3]-[6].

On the other hand, focusing on the design of an autonomous unified reactive power control method with the aims of the system voltage regulation and unintentional islanding problems linked in presence of high penetration of distributed photovoltaic (PV) generation systems are discussed in [8].

Generally, in control loop of most of the power generators with interfaced power electronic converters, the intrinsic kinetic energy buffer that is rotor inertia is not considered, which lack of this inertia leads to instability issues in power grid during connection of large scale renewable energy sources.

In [9], a short-term energy buffer is added to the system by emulation of rotor inertia, called as Virtual Synchronous Generator (VSG) that can reduce instability problems of system operation level.

A synchronous power controller has been proposed in [10] for control of grid-connected converters for integration of renewable energy sources to the power grid.

In this paper, inertia, damping, and flexible droop characteristics are considered to meet the requirements for connection of power converters into the power grid and both dynamics and frequency regulations.

In [11] a novel robot-soccer-coordination inspired control architecture has been proposed for a coordinated operation of an islanded microgrid which this controller is able to perform the voltage and frequency restoration for reaching a complete regulation of the common bus without losing the coordination between distributed generation units.

For a large-scale photovoltaic (PV) farm/plant, a distributed voltage control (DVC) scheme has been presented in [12] to decrease high ramp-rate issues.

Reference [13] employs probabilistic analysis to evaluate the small signal stability of power systems in presence of wind generation high penetration.

Also distributed energy storage systems (DESS) are highly utilized for making power grid stable in large scale integration of renewable energy units into power grid [14]-[16].

To deal with the high penetration of renewable energy systems into power grid, a double synchronous controller (DSC) is performed by analyzing and considering the features of synchronous power generator in this paper, in order to provide coordinated behavior for operation of the interfaced converters. This controller is designed using a new dynamic equation based on active and reactive power.

By the use of the proposed dynamic equation and DSC, the DSC based control technique is able not only to execute accurate active and reactive power sharing, also can perform fast reaction to voltage magnitude and frequency instability to reach desired values for them. The ability of the proposed control technique is validated through stringent simulation results via MATLAB/SIMULINK.

II. THE PROPOSED MODEL

General schematic diagram of the proposed converter-based model is presented in Fig. 1.

As can be seen, a DC-DC converter with a photovoltaic (PV) source is responsible to provide DC-link voltage for a three-phase dc-ac voltage source converter.

To draw a control technique for control of the interfaced converter for integration of renewable energy sources into the grid, dynamic model of the whole model should be extracted.

Therefore, the dynamic equations of the proposed model in d-q reference frame can be expressed as,

$$L \frac{di_d}{dt} + Ri_d - \omega Li_q - u_d v_{dc} + v_d = 0 \quad (1)$$

$$L \frac{di_q}{dt} + Ri_q + \omega Li_d - u_q v_{dc} + v_q = 0 \quad (2)$$

$$C \frac{dv_{dc}}{dt} + u_d i_d + u_q i_q + i_{dc} = 0 \quad (3)$$

where, v_{dq} and i_{dq} are the output voltages and currents of dc-ac converter in d-q reference frame.

Also, v_{dc} , i_{dc} , and u_{dq} are dc-link voltage, dc-link current, and switching state functions of the dc-ac converter in d-q reference frame, respectively.

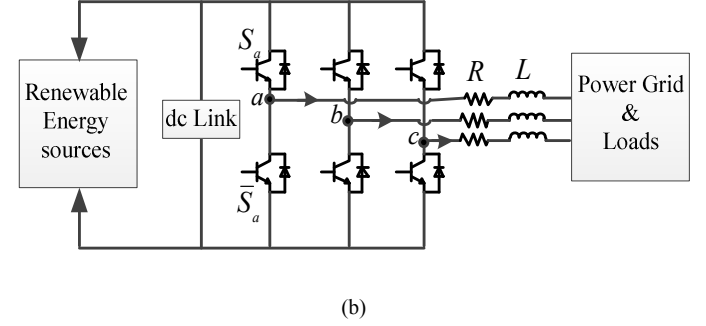
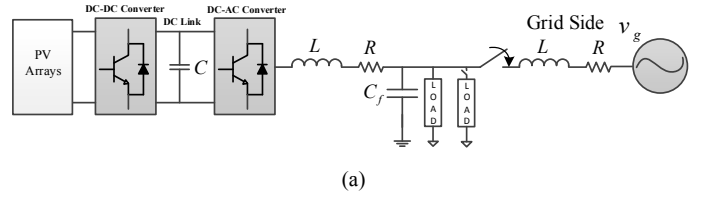

Fig. 1. the proposed model (a) single phase diagram of the grid-connected PV based model, (b) three-phase model included with the interfaced dc-ac converter between renewable energy sources and power grid.

By multiplying v_d in equations (1)-(3) and assuming $P = i_d v_d$, $Q = -i_q v_d$ and neglecting partial variations, a set of new dynamic equations in terms of active and reactive power of the dc-ac converter is achieved as,

$$\frac{L}{R} \frac{dP}{dt} + P + \frac{\omega L}{R} Q - u_d P_{c1} + P_{pd} = 0 \quad (4)$$

$$\frac{L}{R} \frac{dQ}{dt} + Q - \frac{\omega L}{R} P + u_q P_{c1} - P_{pdq} = 0 \quad (5)$$

$$RC \frac{dP_{c1}}{dt} + u_d P - u_q Q + P_{c2} = 0 \quad (6)$$

where, P_{c1} and P_{c2} are power associated with the dc-link voltage and current, and P_{pd} and P_{pdq} are the active power associated with the d and q voltage components of interfaced converter, which can be calculated as,

$$P_{c1} = \frac{v_{dc} v_d}{R} \quad (7)$$

$$P_{c2} = i_{dc} v_d \quad (8)$$

$$P_{pd} = \frac{v_d^2}{R} \quad (9)$$

$$P_{pdq} = \frac{v_d v_q}{R} \quad (10)$$

III. THE PROPOSED CONTROL TECHNIQUE

In this section, the proposed control technique is presented based on the new dynamic equations and also the proposed double synchronous controller.

In the following subsection, DSC is designed in the first step and then the overall structure of the final control method is discussed in the next step with all details.

A. The Proposed Double Synchronous Controller (DSC) Model Analyze

The main concern about the large-scale integration of renewable energy sources to the power grid is the unstable behavior of the utilized control techniques for control of dc-ac converters. To solve this problem, all properties of synchronous generators (SG) are considered in the final proposed control technique as following.

As it is known, the so-called swing equation can be expressed as,

$$J \frac{d\omega}{dt} = \frac{P_m - P}{\omega} \quad (11)$$

where, J , ω , P_m and P are the values of inertia, angular speed, mechanical power and electrical power of SG, respectively. By applying small-signal linearization to (11) and doing some simplifications, (12) can be driven as,

$$\Delta\omega = \frac{1}{\omega^* J} \cdot \frac{\Delta P_m - \Delta P}{s + (P^* - P_m^*) / \omega^{*2} J} \quad (12)$$

In other words, the relationship between the power and the angular speed variations can be demonstrated as,

$$\frac{\Delta P}{s} = \frac{\Delta P_m}{s} - \left(\omega^* J + \frac{(P^* - P_m^*)}{\omega^* s} \right) \Delta\omega \quad (13)$$

By noticing (12) and (13) and adding some control considerations, the proposed DSC can be achieved as shown in Fig. 2. Based on Fig. 2, DSC1 is consisted of all properties of SG which is used for active power-axis of the proposed controller. In this part of DSC, the proportional-integral coefficients of angular speed error PI controller are equal to,

$$\begin{aligned} k_{pm} &= \omega^* J \\ k_{im} &= \frac{P^* - P_m^*}{\omega^*} \end{aligned} \quad (14)$$

According to Fig. 2, DSC2 consists of a mechanical power error and a low pass filter (LPF). In fact, DSC2 is aimed to generate the moment angular speed employed for both active and reactive-axis of the proposed control method. Also, the angular speed driven by DSC2 is used for DSC1 as well.

By noticing Fig. 3, the switching functions of dc-ac converter can be achieved as (15) and (16),

$$u_d = \frac{1}{P_{c1}} \left((\Delta P - \Delta P_m) (k_{pp} + k_{ip} / s) + (\Delta\omega) (k_{pm} + k_{im} / s) + \frac{\omega L}{R} Q + P_{pd} \right) \quad (15)$$

$$u_q = \frac{-1}{P_{c1}} \left(\Delta Q (k_{pq} + k_{iq} / s) + \frac{\omega L}{R} P + P_{pdq} \right) \quad (16)$$

The proposed switching functions of (15) and (16) are made to provide the synchronous behavior for PWM dc-ac converter.

B. The Proposed Control Technique

By use of the power based dynamic equations of (4)-(6) and the DSC illustrated in Fig. 2, the proposed control method can be performed as depicted in Fig. 3. As can be seen from this figure, a modified feed-forward (decoupled) power-based control technique included both DSC1 and DSC2 is performed to control the proposed converter-based model shown in Fig. 1, with the aim of synchronous regulation performance analogous SG operation.

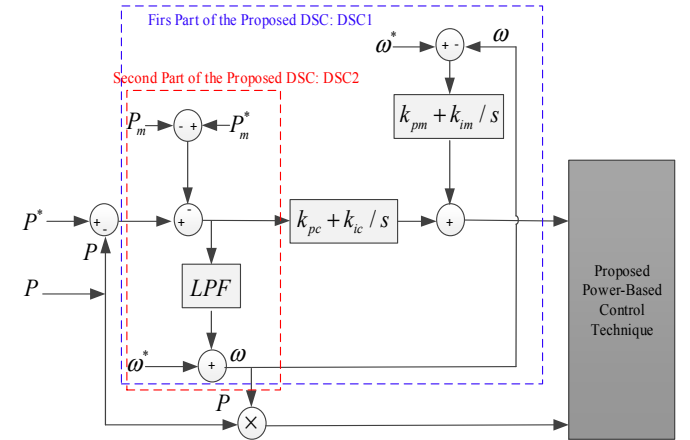

Fig. 2. General structure of the proposed Double Synchronous Controller.

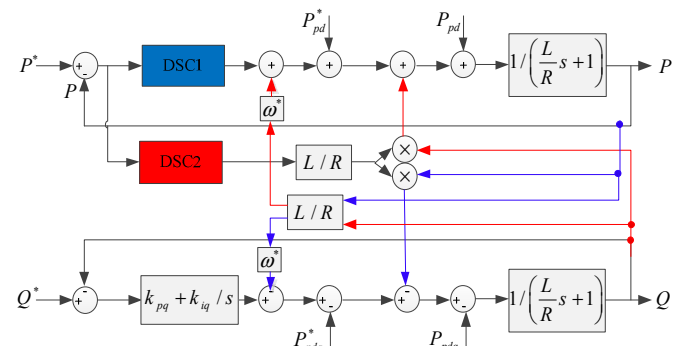

Fig. 3. General structure of the proposed Power-Based control technique consisting of DSC.

To further evaluate the DSC responsibilities, it can be understood from Fig. 3 that DSC1 can exclusively impact on the accuracy of synchronous active power sharing of DG unit. Moreover, DSC2 has high effect on the decoupling properties of the proposed control technique which should be considered in more regulations of DSC.

IV. RESULTS AND DISCUSSION

The complete system model proposed in Fig.1 is simulated using the ‘Power System Blockset’ simulator operating under the Matlab/Simulink environment, in order to demonstrate the high performance of the proposed control technique for control of the interfaced converters and integration of renewable energy sources into the power grid and/or loads, in grid connected and islanded operating modes.

The network parameters, including the ratings and impedances of the proposed model components for simulation analysis, are given in Table I.

As the first step, the renewable energy source is regulated to supply a load of $6\text{kW}+j3.5\text{kVAR}$ in grid-connected mode. At the same mode, another load with the value of $4\text{kW}+j2\text{kVAR}$ is added at $t=0.1\text{s}$. This operation is continued until $t=0.2\text{s}$, while the operation of interfaced converter is changed to the islanded mode with the same load and should continue its performance for supplying the load in this operating mode.

Fig. 4 shows the output *ac* voltages of the interfaced-converter during both operating modes. As can be seen, in grid-connected mode, three phase *ac* voltages are kept in its steady state waveforms without any transient time. Immediately after the operation mode changes to the islanded mode, a fast-transient response can be observed and then the desired waveforms are achieved in an acceptable response range.

TABLE I
SIMULATION PARAMETERS

Parameter	Value
<i>dc</i> -link voltage (v_{dc})	850 V
<i>ac</i> voltage	310 V
Fundamental frequency	50 Hz
Switching/Sampling frequency	10 kHz
SPVSI resistance	0.25 Ω
SPVSI inductance	30 mH
J	7.5 s
ΔP_m	10 W
Load 1	$6+j3.5$
Load 2	$4+j2$

The output *ac* currents of the interfaced-converter is illustrated in Fig. 5. Based on this figure, increasing the *ac* currents is happened proportional to the load changes and after making islanded mode, this increment is remained with a proper transient response.

The frequency of three phase *ac* voltages is illustrated in Fig. 6. When the load increment occurs at $t=0.2\text{s}$, a drop happens for PCC voltage frequency as depicted in Fig.6. As it can be seen from this figure, the *ac* voltages frequency is placed closed to the 50 Hz after a very short transient time, which very proper from the view point of controller operation.

In the time of load increment, the voltage magnitude experiences some fluctuations which will be damped in very short transient time as shown in Fig.7.

Also, when islanding mode occurs, some slight undershoot and overshoot happen and then the magnitude completely tracks its reference value.

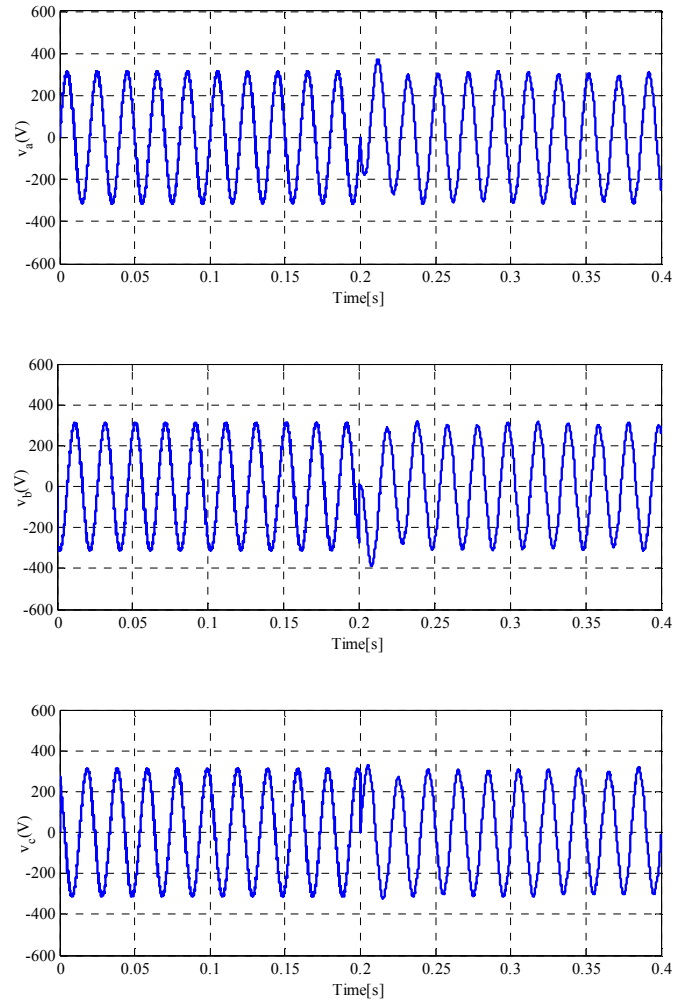

Fig. 4. Three phase *ac* voltages of interfaced-converter in both grid-connected and islanded operating modes.

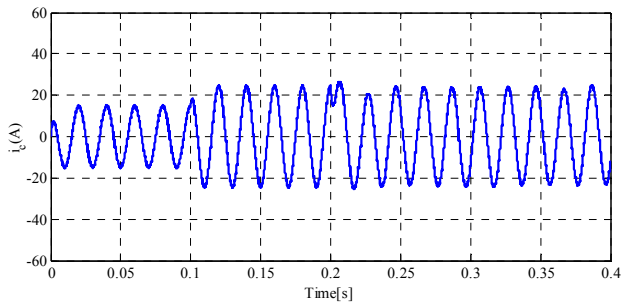
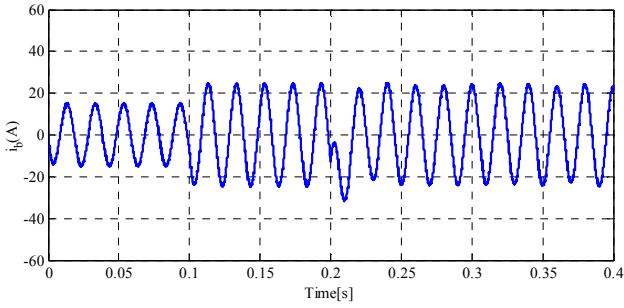
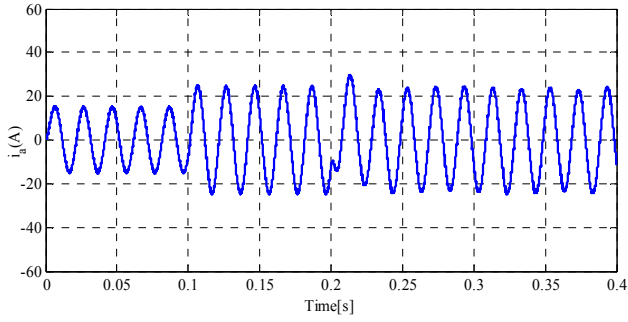

Fig. 5. Three phase ac currents of interfaced-converter in both grid-connected and islanded operating modes.

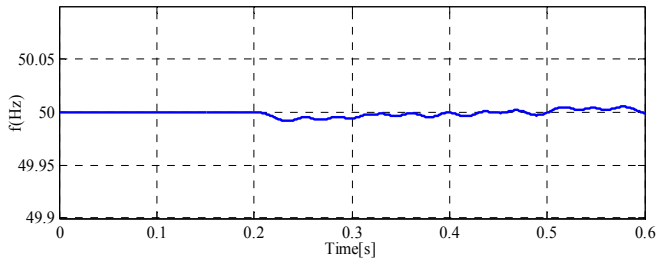

Fig. 6. Frequency of three phase ac voltages.

The ability of the proposed control technique for tracking the active and reactive power desired values is depicted in Fig. 8 and Fig. 9.

As it can be seen from the Fig. 8, the tracking of load active power variations is accurately done in grid connected mode which follows all the active power of grid connected loads before and after load increment. After the operation mode changes to the islanded mode, the proper active power tracking is continued with very low fluctuations.

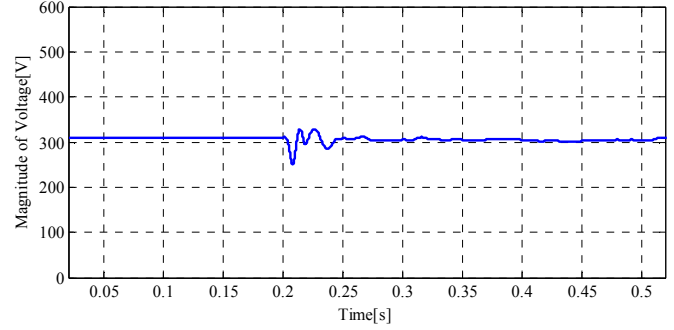

Fig. 7. Voltage Magnitude of three phase ac voltages.

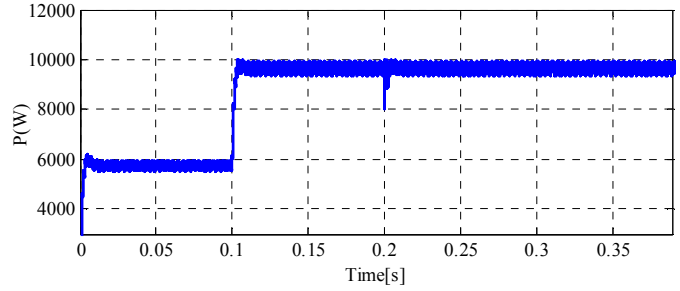

Fig. 8. Active power injected from the interfaced-converter.

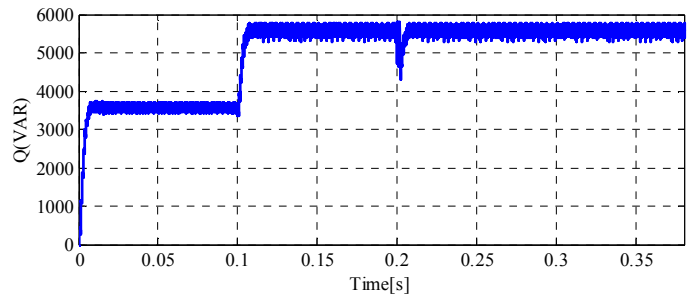

Fig. 9. Reactive power injected from the interfaced-converter.

The reactive power injection from the interfaced-converter to the loads, before and after load increment, and for both of grid-connected and islanded operating modes is shown in Fig. 9.

As shown in this figure, the same consequence happens for the reactive power compensation, in which the tracking of desired values is properly executed for reactive power of the system. In both active and reactive power, the proposed controller is able to quickly damp the transient responses.

V. CONCLUSION

An innovative double synchronous control technique has been proposed in this paper for the integration of large-scale

renewable energy sources into the power grid. The features of synchronous generators have been considered in the structure of the proposed control technique for the interfaced converter to integrate renewable energy sources into the power grid. The control technique has been developed based on a new dynamic model made by active and reactive powers state variables. This control technique is influenced by the proposed DSC in both its active and reactive control axis. The application of the proposed control technique can guarantee the stability of the power grid during the integration of large-scale renewable energy sources into the power grid. The high performance of the proposed control technique was validated through stringent simulation results in MATLAB/SIMULINK environment under different operation conditions.

ACKNOWLEDGMENTS

This work was supported by INSUL'GRID project, France, by FEDER funds through COMPETE 2020 and by Portuguese funds through FCT, under Projects SAICT-PAC/0004/2015 - POCI-01-0145-FEDER-016434, POCI-01-0145-FEDER-006961, UID/EEA/50014/2013, UID/CEC/50021/2013, UID/EMS/00151/2013, and SFRH/BPD/102744/2014. Also, the research leading to these results has received funding from the EU Seventh Framework Programme FP7/2007-2013 under grant agreement no. 309048.

REFERENCES

- [1] E. Pouresmaeil, D. Montesinos-Miracle, and O. Gomis-Bellmunt, "Control scheme of three-level H-bridge converter for interfacing between renewable energy resources and AC grid," in *Proc. 14th IEEE Proceedings of the European Conference on Power Electronics and Applications (EPE)*, pp.1-9, Aug. 2011.
- [2] M. Mehraza, M. E. Adabi, E. Pouresmaeil, J. Adabi, "Passivity-based control technique for integration of DG resources into the power grid," *International Journal of Electric Power Systems Research*, vol. 58, pp. 281-290, January. 2014.
- [3] M. Mehraza, E. Pouresmaeil, B. N. Jørgensen, J. P.S. Catalão, "A control plan for the stable operation of microgrids during grid-connected and islanded modes," *Electric Power Systems Research*, vol. 129, pp. 10-22, July. 2015.
- [4] W. Yan, W. Cui, W-J. Lee, J. Yu, and X. Zhao, " Pilot-Bus-Centered Automatic Voltage Control With High Penetration Level of Wind Generation," *IEEE Trans. Industry Applications*, vol. 52, pp. 1962-1969, May/June. 2016.
- [5] S. K. Sharma, A. Chandra, M. Saad, S. Lefebvre, D. Asber, and L. Lenoir, " Voltage Flicker Mitigation Employing Smart Loads With High Penetration of Renewable Energy in Distribution Systems," *IEEE Trans. Sustainable Energy*, vol. 8, pp. 414-424, Jan. 2017.
- [6] M. Zeraati, M. E. H. Golshan, and J. M. Guerrero, " Distributed Control of Battery Energy Storage Systems for Voltage Regulation in Distribution Networks with High PV Penetration," *IEEE Trans. Smart Grid*, DOI 10.1109/TSG.2016.2636217.
- [7] X. Xing, J. Lin, C. Wan, and Y. Song, " Model Predictive Control of LPC-looped Active Distribution Network with High Penetration of Distributed Generation," *IEEE Trans. Sustainable Energy*, DOI 10.1109/TSTE.2016.2647259.
- [8] Y. Zhou, H. Li, and L. Liu, "Integrated Autonomous Voltage Regulation and Islanding Detection for High Penetration PV Applications," *IEEE Trans. Power Electronics*, vol. 28, pp. 2826-2841, Jun. 2013.
- [9] M.P.N.V Wesenbeeck, S.W.H.D Haan, P. Varela and K. Visscher, "Grid Tied Converter with Virtual Kinetic Storage," in *Proc. 2009 IEEE Bucharest Power Tech Conf.*, pp. 1-7.
- [10] W. Zhang, A. M. Cantarellas, J. Rocabert, A. Luna, and P. Rodriguez, "Synchronous Power Controller With Flexible Droop Characteristics for Renewable Power Generation Systems," *IEEE Trans. Sustainable Energy*, vol. 7, pp. 1572-1582, October. 2016.
- [11] N. L. Diaz, J. G. Guarnizo, M. Mellado, J. C. Vasquez, and J. M. Guerrero, " A Robot-Soccer-Coordination Inspired Control Architecture Applied to Islanded Microgrids," *IEEE Trans. Power Electronics*, vol. 32, pp. 2728-2742, April. 2017.
- [12] M. Chamana, B. H. Chowdhury, and F. Jahanbakhsh, " Distributed Control of Voltage Regulating Devices in the Presence of High PV Penetration to Mitigate Ramp-Rate Issues," *IEEE Trans. Smart Grid*, DOI 10.1109/TSG.2016.2576405.
- [13] Z. W. Wang, C. Shen, and F. Liu, " Probabilistic Analysis of Small Signal Stability for Power Systems With High Penetration of Wind Generation," *IEEE Trans. Sustainable Energy*, Vol. 7, pp. 1182-1193, July. 2016.
- [14] S. Liu, X. Wang, and P. X. Liu, " A Stochastic Stability Enhancement Method of Grid-Connected Distributed Energy Storage Systems," *IEEE Trans. Smart Grid*, DOI: 10.1109/TSG.2015.2514286.
- [15] S. K. Hoseini, E. Pouresmaeil, S. H. Hosseinnia, and J. P. S. Catalao, "A Control Approach for the Operation of DG units Under Variations of Interfacing Impedance in Grid-Connected Mode," *International Journal of Electrical Power and Energy Systems (IJEPES)*, vol. 74, pp. 1-8, Jan. 2016
- [16] M. A. Torres, L. A. Lopes, L. A. Moran, and J. R. Espinoza, "Self-tuning virtual synchronous machine: A control strategy for energy storage systems to support dynamic frequency control," *IEEE Trans. Energy Convers.*, vol. 29, no. 4, pp. 833-840, Dec. 2014.