



HAL
open science

The internationalization of family SME

Sami Basly

► **To cite this version:**

Sami Basly. The internationalization of family SME: An organizational learning and knowledge development perspective. *Baltic Journal of Management*, 2007, 2 (2), pp.154-180. 10.1108/17465260710750973 . hal-00465863

HAL Id: hal-00465863

<https://hal.science/hal-00465863>

Submitted on 22 Mar 2010

HAL is a multi-disciplinary open access archive for the deposit and dissemination of scientific research documents, whether they are published or not. The documents may come from teaching and research institutions in France or abroad, or from public or private research centers.

L'archive ouverte pluridisciplinaire **HAL**, est destinée au dépôt et à la diffusion de documents scientifiques de niveau recherche, publiés ou non, émanant des établissements d'enseignement et de recherche français ou étrangers, des laboratoires publics ou privés.

The internationalization of family SME: An organizational learning and knowledge development perspective

Abstract

Purpose – Due to its specificities, the family Small and Medium Enterprise shows a particular behavior as for the creation, development, sharing, protection and transmission of knowledge. The purpose of this paper is to study the specificities of the processes of knowledge creation and development in family firms. Three variables should influence the processes of knowledge development. The characteristics underlined by the literature as being specific to the small and medium-sized family firms are conservatism, independence orientation and social networking. We study particularly the influence of these characteristics on the development of the knowledge base in a context of internationalization.

We conceive internationalization as a process of organizational learning and knowledge development (Eriksson and ali., 2000). Johansson and Vahlne (1977) studied market knowledge composed of objective knowledge, on the one hand, and experiential knowledge, on the other hand. Whereas market knowledge refers primarily to relevant information relating to markets and allowing the penetration, the establishment and the exploitation, internationalization knowledge is the competence accumulated by the firm, knowledge carried by the women and men who manage and take part in international activities. Indeed, international expansion of firms does not depend on the only knowledge relating to a specific market but on various aspects of knowledge relating to the international activity. Eriksson and ali. (1997, 2000) analyze thoroughly the different dimensions of knowledge in the context of internationalization. In addition to operational and institutional knowledge, internationalization knowledge is crucial. Autio and ali. (2000) explain the rapid international growth of entrepreneurial firms by the high international knowledge. Because it is difficult to obtain and reproduce, Knight and Liesch (2002) argue that tacit internationalization knowledge provides a competitive advantage for the internationalizing firm.

H1: Internationalization knowledge positively influences the degree of internationalization of the firm.

Internationalizing implies the beginning of a new activity (new markets, new customers, new competitors, etc.) weakly connected to the original activity (Gallo and Sveen, 1991). So that internationalization starts, a motivation for change, for strategic revival and adaptation to the new requirements of the environment are necessary. However, the usual conservative attitude of the family business can inhibit such a change. The literature suggests that the family system attempts to create and maintain a cohesiveness that supports the family "paradigm" which is described as the core assumptions, beliefs, and convictions that the family holds in relation to its environment. Information that is not consistent with this paradigm is resisted or ignored (Davis, 1983). The more the family is conservative the less it works for change. As a consequence, the level of internationalization knowledge would be weak. More quantitatively the family firm would exhibit a weak degree of internationalization.

H2: Conservatism negatively influences the level of internationalization knowledge.

The independence orientation is a consequence of the family long-term commitment to the business. Paradoxically, this commitment has two contradictory effects on growth. First, it

implies the pursuit of future development and continuity of the firm to make sure that the family heritage is passed on to the following generations. On the other hand, commitment implies a strategy of conservation of the heritage which passes by a strong seek for the independence. Aiming to guarantee its continuity, the (small and medium-sized) family firm establishes an independence orientation of three different types. First, from the financial point of view, it avoids as much as possible turning to outside partners (Hirigoyen, 1985). Then, on the human plan, it would be favorable to the appointment of family members or individuals belonging to the close relational circle to the posts of direction and would be reluctant to the recruitment of professional directors. Finally, to maintain the decision-making in hands of the family, the family firm tends to avoid the inter-organizational relations, cooperative investments, and tries to limit the sharing of control of its investments. The contribution of the outsiders (financiers, directors or partner organizations) can, however, be precious to the company. And the introversion would be a major obstacle to the perpetuity of the firm because it inhibits growth. Independence orientation limits the accumulation of internationalization knowledge because, on one hand, the horizons of the company will be limited and little varied, and on the other hand, the potential valuable knowledge contribution of the outsiders is excluded. As a consequence, the more the direction of the firm wishes the independence the more the internationalization will be slowed down.

H3: Independence orientation negatively influences the level of internationalization knowledge.

The family firm shows a weak cooperative orientation in the sense of the pursuit of common objectives with an economic partner but a strong orientation toward social networking. It favors social relationships to economic ones that risk alienating its decision-making independence. Indeed, the family firm relies enormously on its family relations in the broad sense of the term during its internationalization. The members of the family either assigned abroad or already present on the foreign markets form "an internationally spread family" (Fan, 1998) which is able to mobilize resources and especially knowledge of markets to conquer. This knowledge permits to reduce uncertainty (Johanson and Vahlne, 1977) because the relations of the social ties established abroad are more capable to evaluate opportunities and risks, and manage and govern effectively the activities. The social network not only allows the family firm to develop a high awareness of opportunities and threats in relation to its activity, because it exposes it strongly to environment, but also permits to base decisions and actions (concerning the strategy of internationalization for example) on an imitation of other actors of the network, considered as more legitimate because of their experience. Lastly, the social network allows a direct transfer of knowledge between the various participants.

H4: Social networking positively influences the level of internationalization knowledge.

Design/methodology/approach – Through a questionnaire, we tested the hypotheses of our model. The measurement of constructs is based on the one hand on scales existing in the literature and on the other hand on the development of new scales. Indeed, several empirical studies were first used to build the study questionnaire. Besides, the new scales were developed through the literature review and an exploratory study. The questionnaire was pre-tested in order to check for the validity of content. All the items, except for the scale of internationalization knowledge, were evaluated on a Likert scale of 5 points. The collection of data by questionnaire was carried out in two stages. The strategy of collection of the responses was carried out exclusively through Internet.

The study is based on 118 firms belonging to various industries. The age of the firms

of the sample varies between 5 and 254 years with an average is 54,8 years. More than 58% of the firms are controlled mainly by the family and approximately 36% of the firms are still directed by their founders.

After, evaluating the reliability and validity of the items through exploratory and confirmatory factor analysis, the model was tested through structural equation modeling (LISREL). Several iterations were carried out in order to obtain the best interpretable model. Refinements were operated on the basis of initial theoretical construction and 5 various models were compared.

Findings – The model retained induces the following conclusions:

- Internationalization knowledge positively influences the degree of internationalization of the firm (H4 confirmed).
- The conservatism of family SME does not directly influence the level of internationalization knowledge. The influence of conservatism on internationalization knowledge is exerted only through the decisional dimension of independence orientation (H1 partially confirmed).
- The independence orientation of family SME, then with its two dimensions simultaneously (decisional and resource independence), does not significantly influence internationalization knowledge. Contrary to decisional independence which influences indirectly the degree of internationalization (thanks to the intermediation of internationalization knowledge), resource independence influences directly the dependant variable. The mediation of internationalization knowledge of is thus not totally proven (H2 partially confirmed)
- Social networking positively influences the amount of internationalization knowledge (H3 confirmed).

Research limitations/implications – A major weakness is the absence of a synchronic approach as the dependant and independent variables are measured at the same moment. A more longitudinal approach would be valuable to analyze the causal relationships between the independent variables and internationalization knowledge and degree of internationalization. A second limitation is that the characteristics of the sample may limit the generalizability of the results.

Originality/value – The paper is the first of its kind to examine the knowledge-based processes in family businesses.

Keywords: Family business, internationalization, organizational knowledge, independence orientation, conservatism, networking

Article Type: Research paper

The internationalization of family SME: An organizational learning and knowledge development perspective

Introduction

Despite the profusion of research about knowledge-based processes within the firm, rare studies tried to analyze them for the family firmⁱ. The family firm can be defined as a firm controlled by one or more families involved in governance or management or at least holding capital stakes in this organizationⁱⁱ. Due to its specificities, this entity exhibits a specific behavior as for the creation, development, sharing, protection and transmission of knowledge. Habbershon and Williams (1999) initiated the research aiming at the identification of the specific resources of the family firm. But, more than specific resources and capacities, the family firm uses a collective tacit knowledge needed to integrate, coordinate and mobilize effectively its resources (Cabrera-Suarez et al., 2002). The aim of the present contribution is to analyze the characteristics of the family firm critical to the knowledge-based processes. Due to its founding characteristics, family SME seems to be a closed, hermetic and rigid organization. Although this description can be criticized and challenged, it remains valid for many of these entities. The interaction between the family system and the firm system appears to be the essential element preventing the organization from quickly adapting to the changing conditions (Moloktos, 1991). Moloktos (1991) explains that when the life cycles of these two systems do not evolve at the same speed, the risks of crisis are significant. Thus, conservatism constitutes a first obstacle to knowledge development. Besides, small and medium family enterprise is strongly oriented towards independence which has advantages but also many drawbacks. The impact of this orientation on the system of resources and in particular on knowledge can be crucial. Conversely, the family firm is characterized by social networking which impact on knowledge development is positive. In this article, we will study the influence of these three variables on the knowledge base of the firm in a context of internationalization.

Research which explicitly conceived the internationalization of the firm as a process of organizational learning is infrequent. At most, this phenomenon is deemed as underlying the process of resource commitment abroad. Here, we analyze internationalization in the light of the theoretical developments about learning and knowledge development within the organization. Internationalization can be conceived as a process of learning and accumulation of knowledge (Eriksson et al., 2000). Johanson and Vahlne (1977) took the first steps in considering knowledge within the context of internationalization. The stream of the literature initiated by these authors analyzes the process of international development as a sequence of steps permitting to the firm to gain knowledge of international environment. The move from

one stage of commitment to another as well as the move from a given market to another are done incrementally. This incremental dynamics is precisely justified by an underlying process of foreign market knowledge development. Built on the analysis of Carlson (1966), this reasoning suggests more precisely that the firm managers fight against uncertainty through two strategies implying the development of two distinct forms of knowledge. The first mode to reduce uncertainty is based on a process of acquisition of objective information, on a cognitive learning. For instance, Knight and Liesch (2002) emphasize that the process of internalization of information and its translation into relevant knowledge is a fundamental step in order to accomplish an internationalization project whatever its form or its localization. The second way of reducing uncertainty is the engagement of the firm in an action-based international expansion permitting to develop an international competence incrementally and cumulatively. Johanson and Vahlne (1977) distinguish between objective knowledge and experiential knowledge (Penrose, 1959). The first is a public good and therefore transferable at a weak or null cost. The latter is unique to the firm since it is acquired only through market experience. Recently, Eriksson et al. (1997, 2000) analyzed more thoroughly the different dimensions of knowledge relevant to international operations. In addition to operational and institutional knowledge, internationalization knowledge is of a crucial importance. In sum, two dimensions of knowledge, a resource and a competence, are together necessary and underlie the progression of the firm through the dimensions of internationalization (modes of entry, markets, products, etc). The first is the market knowledge which is constituted of a set of information in relation to a specific market or a number of markets. Johanson and Vahlne (1977) deal with this type of knowledge which requires obviously the activity on the market but could especially be acquired in an explicit form through cognitive learning. The second type of knowledge is synonymous of international competence. Behavioral learning largely contributes to the development of this knowledge whose form is primarily tacit.

This article is structured as follow: after analyzing the main idiosyncratic variables influencing the development of internationalization knowledge, we discuss some theoretical implications. Indeed, the study of these variables raises questions about the efficacy of the organizational memory within the family firm. This organization runs particular risks because of the peculiarity of its knowledge management mechanisms. Intergenerational transmission and transfer of knowledge could be the solution to protect and perpetuate valuable knowledge.

1. Theoretical framework and research model

Three variables are distinctive as for the processes of knowledge development within family SME. These are characteristics frequently emphasized by the literature as being specific to this organization. We will study the effects of conservatism (1.1), independence orientation (1.2) and social networking (1.3) on the development of the knowledge base of small and medium family enterprise.

1.1. Internationalization knowledge

We conceive internationalization as a process of organizational learning and knowledge development (Eriksson and ali., 2000). Johansson and Vahlne (1977) studied market knowledge composed of objective knowledge, on the one hand, and experiential knowledge, on the other hand. Whereas market knowledge refers primarily to relevant information relating to markets and allowing the penetration, the establishment and the exploitation, internationalization knowledge is the competence accumulated by the firm, knowledge carried by the women and men who manage and take part in international activities. Indeed, international expansion of firms does not depend on the only knowledge relating to a specific market but on various aspects of knowledge relating to the international activity. Eriksson and ali. (1997, 2000) analyze thoroughly the different dimensions of knowledge in the context of internationalization. In addition to operational and institutional knowledge, internationalization knowledge is crucial. Autio and ali. (2000) explain the rapid international growth of entrepreneurial firms by the high international knowledge. Because it is difficult to obtain and reproduce, Knight and Liesch (2002) argue that tacit internationalization knowledge provides a competitive advantage for the internationalizing firm.

H1: Internationalization knowledge positively influences the degree of internationalization of the firm.

1.2. Conservatism

The conservatism limits the variation and accordingly the extent of knowledge developed by the firm. Indeed, the literature stresses that this variation, i.e. the diversity of environments to which the firm is exposed, is strongly correlated with the amount of knowledge accumulated and developed. Organizations exposed to a variety of business and institutional actors are likely to develop knowledge of an important set of events and thus learn more than poorly exposed ones. They are more able to define problems, errors and opportunities than firms whose horizon of action is more reduced (Eriksson et al., 2000). The weak variation indeed implies a limited number of customers, competitors and other institutional actors. Accordingly, conservative organizations carry out only a simple loop learning which does not reform their theories-in-uses since they accumulate little knowledge.

Conservatism is the attachment to the choices of the past (Timur, 1988). The literature about cultural specificities emphasizes the maintenance of the *status quo* and harmonious relations not only within the group but also within the entire society. The pursuit of security, conformism and tradition are characteristic of conservative organizations. Particularly with the family firm, Miller et al. (2003) explain that the conservative posture of this entity is reflected on its governance, strategy and organization (mainly culture). We will discuss these three components in order to be able to understand their impact on the family SME knowledge base.

1.2.1. Conservatism and firm governance

The first sphere concerned with conservatism is the governance of the firmⁱⁱⁱ. Conservative organizations and particularly family firms are characterized by the persistence and substantial power of old generations who exert a strong supervision on the owner-manager. Otherwise, conservatism can be due to the owner-manager himself. He plays a significant role in the processes of organizational learning and influences the strategic posture that his firm adopts. A patriarchal family controlling a paternalist organization is the ultimate case of figure (Jenster and Malone, 1991): being dependent to a high degree on its founder, the organization would be unable to promote change as it is not instigated by the founder. However, the founder or owner-manager may be unwilling to promote change. Hambrick, Geletkanycz and Fredrickson (1993) call this tendency to slow down the change “commitment to the *status quo*” (CSQ). The management believes in the permanent accuracy of current strategies or organizational behaviors (Hambrick et al., 1993). Therefore, personal

paradigms which by the past proved their efficacy constitute inhibitors to change. Thus, in spite of the evolution of the environment and performance requirements, the owner-manager could become inflexible and rigid by promoting practices and strategies resulting from past successes and avoiding decisions which can threaten his image or his economic wealth (Ward, 1997). Consequently, he perceives a weak need for adjustment even in case of critical changes in the external environment. In sum, the conservatism of the owner-manager constitutes a significant barrier to organizational learning and knowledge development within family SME.

The efficacy of the board of directors^{iv} is an indicator of the struggle against conservatism and strategic inertia. According to theoretical descriptions, this corporate body constitutes a source of strategic initiative and relevant information and also a source of expertise, counsel and control since it must also correct the trajectory in case of unsatisfactory management. However, its role within family SME needs to be moderated. Mustakallio and Autio (2001) argue that the role of the board of directors, measured by its composition and by the intensity of control it exerts, would be more significant as the implication of the family members in the management decreases - suggesting at the opposite that the more the family is involved, the less decisive the role of the board would be. In general, the traditional family firm is known to have a board of directors whose members, selected according to their status and influence within the family and not according to their knowledge of the activity or industry, occupy their positions for long periods and have insufficient or inadequate professional competences. According to this description, they constitute a barrier to any attempt of change potentially threatening the stability of the firm. Ranft and O'Neill (2001), notice that the founders of high-performing firms are even tempted to weaken deliberately the board of directors of their firms in order to maintain the *status quo*. The inward orientation is more corroborated in some family firms who simply do not implement such a body (Melin and Nordqvist, 2000).

However, the role of the board of directors can be crucial since it should increase the amount of information available to the operational management when planning or implementing strategies. This role is accomplished by insiders as well as external administrators^v. The insiders contribute through their thorough comprehension of the firm. The outsiders would prevent from the dominance of a single line of thought by challenging the assumptions underlying the firm's strategies and injecting external knowledge. The results obtained by Schwartz and Barnes (1991), based on a sample of 262 family firms, prove the relevance of the incorporation of external administrators. The authors find that they provide unbiased points of view and constitute a precious means for the establishment of networks. As

far as the internationalization of the firm is concerned, Sanders and Carpenter (1998) prove the existence of a significant relation between internationalization and the composition of the board. First, it is suggested that the size of the board of directors increases according to the intensity of international activities. Moreover, the authors find that the proportion of outsiders in the board of directors increases with internationalization. In brief, the role of counsel accomplished by the board would have a significant influence on the strategic orientation of the firm by improving the variety and quality of information available for the strategic processes and, consequently, the variation, selection and retention of alternative paths of development (Mustakallio and Autio, 2002). This function of counsel should thus improve the capacity of the firm to innovate and establish new strategic directions such as internationalization.

The study of the conservatism of the family firm governance is necessary because this phenomenon has consequences on firm's strategy selection and implementation. An analysis of the strategic manifestations of this posture will, consequently, be outlined.

1.2.2. Strategic conservatism

Second, the conservatism of the firm is expressed strategically. Generally, the family firm has a tendency to be strongly devoted to a strategy which becomes a source of rigidity. Thus, strategy and pursued business goals constitute factors inhibiting the trigger of internationalization (Gallo and Sveen, 1991). The literature suggests that the family system attempts to create and maintain a cohesiveness that supports the family "paradigm" which is described as the core assumptions, beliefs, and convictions that the family holds in relation to its environment (Gudmundson et al., 1999). Information that is not consistent with this paradigm is resisted or ignored (Davis, 1983). The more the family is conservative the less it works for change. Strategic conservatism implies stagnation and risk of insularity (Miller et al., 2003). The firm carries out few changes in its objectives, business and lines of product or markets (Miller et al., 2003). Generally, family SME is known to maintain its differentiation through the same activities and policies (Gallo and Sveen, 1991) and to privilege a defensive position with protection of its niche. Accordingly, its market shares are likely to be narrowing and its market potential exhausting. However, internationalizing implies the beginning of a new activity (new markets, new customers, new competitors, etc.) weakly connected to the original activity (Gallo and Sveen, 1991). So that internationalization starts, a motivation for change, for strategic revival and adaptation to the new requirements of the environment are

necessary. For instance, Ward (1988) stresses that the succeeding family firm renews its business strategy several times as the market and competitive pressures evolve.

In sum, the usual conservative attitude of the family business can inhibit internationalization. In fact, the organizational learning remains weak since the direction focuses primarily on problem solving rather than on the search and pursuit of new opportunities. Indeed, it deals exclusively with internal issues relative to the efficiency of operations or the quality of products and neglects issues pertaining to the evolution of market requirements or consumers needs.

The third dimension where conservatism can appear is the culture of the firm. Instead of nurturing the will of change and development, cultural conservatism implies characteristics of preservation and rigidity.

1.2.3. Cultural conservatism

The pursuit of the goal of culture and identity protection constitutes the last element exerting a negative influence on learning orientation within family SME. Many authors emphasize the central role of culture and values in shaping the competitive posture of this organization (Dyer, 1986). For instance, analyzing values in the family firm, Salvato et al. (2002) show that they influence activities and routines of the organization aiming to create a competitive advantage. The family firms show an inclination to be independent from their environment and the external culture (Donckels and Fröhlich, 1991). In addition, they insist on artifacts which generally originate from the firm's local environment and are the result of the influence of certain members of the family, in particular that of the founder (Gallo and Sveen, 1991). Consequently, cultural conservatism inhibits any will of change and learning.

H2: Conservatism negatively influences the level of internationalization knowledge.

1.3. Independence orientation

The second variable influencing the processes of knowledge development within family SME is independence orientation. The independence orientation is a consequence of the family long-term commitment to the business. Paradoxically, this commitment has two contradictory effects on growth. First, it implies the pursuit of future development and continuity of the firm to make sure that the family heritage is passed on to the following

generations. On the other hand, commitment implies a strategy of conservation of the heritage which passes by a strong seek for the independence. Aiming to guarantee its continuity, family SME establishes an independence orientation on three levels (see Figure 1).

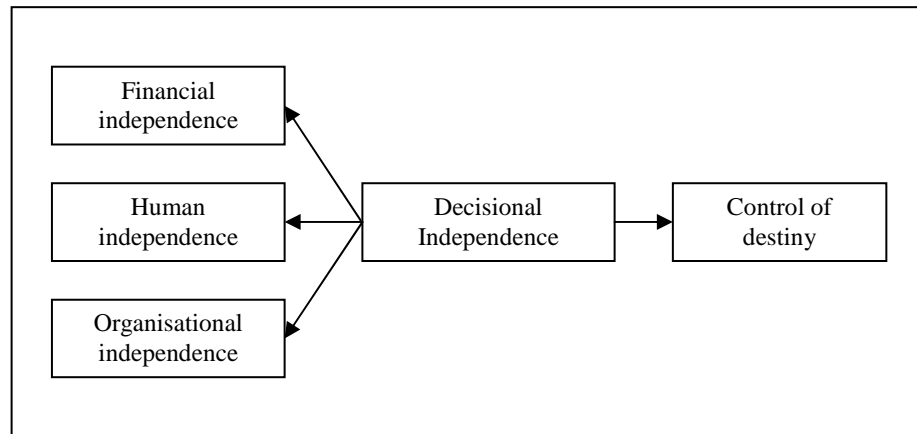

Figure 1 : Dimensions of the independence orientation

First, from the financial point of view, it avoids as much as possible turning to outside partners (Hirigoyen, 1985). Then, on the human plan, it would be favorable to the appointment of family members or individuals belonging to the close relational circle to the posts of direction and would be reluctant to the recruitment of professional directors (Astrachan and Kolenko, 1996; King et al., 2001). Finally, to maintain the decision-making in hands of the family, the family firm tends to avoid the inter-organizational relations, cooperative investments, and tries to limit the sharing of control of its investments (Donckels and Fröhlich, 1991). The contribution of the outsiders (financiers, directors or partner organizations) can, however, be precious to the company. And the introversion would be a major obstacle to the perpetuity of the firm because it inhibits growth. Independence orientation limits the accumulation of internationalization knowledge because, on one hand, the horizons of the company will be limited and little varied, and on the other hand, the potential valuable knowledge contribution of the outsiders is excluded. As a consequence, the more the direction of the firm wishes the independence the more the internationalization will be slowed down.

1.3.1. The financial dimension of independence orientation

Devoted to its goal of continuity, family SME tries to evolve in a more or less hermetic universe. Accordingly, external financial intervention is avoided because it could deteriorate the independence of the firm. The resource dependence theory provides an explanation to this attitude (Davis et al., 2000): the higher the dependence to the (resource) capital, the more the potential financier would have greater power and influence in the decision-making within the firm (Davis et al., 2000). Consequently, family SME seems reluctant to adopt modes of financing other than internal ones. Schematically, it appears strongly predisposed to implement or at least to adhere to the recommendations of the pecking order theory (Myers and Majluf, 1984). It favors generally internal financing by the retention of earnings and the constitution of reserves. Moreover, it avoids opening financially to external sources. First, it tends to avoid debt and relies enormously on costly internal capital. Financing through equity has other specificities that fear family SME. Quotation, for instance, could indeed involve a major change in the ownership structure and governance of the firm due to the entry of external shareholders (Schulze et al., 2003).

Financial independence has significant consequences on the knowledge base of the firm. Initially, in a managerial vision of the firm, internal financing helps to avoid the diffusion of the cognitive map of management and endangering growth opportunities not perceived by competitors (Charreaux, 2002). However, this advantage is compensated by the fact that, at the same time, internal financing implies an inward orientation and a weak development of the knowledge base as it prevents from the penetration of a potentially relevant external cognitive contribution. In addition, debt avoidance, even if it permits to limit the risk of diffusion of information and management cognitive schemas towards bankers implies a lot of disadvantages relatively to the firm's knowledge base. Indeed, the contribution of the bank could be valuable since it can take part in the development of the knowledge base through adhering or enriching the management vision and cognitive map (Charreaux, 2002). Lastly, external shareholders can play a valuable role as for the firm's knowledge base. First, they could exert their influence on the development of the vision of the firm. Then, they can play a significant role in providing proposals for investment opportunities. External ownership thus makes it possible to extend the knowledge base.

Family SME don't recognize these valuable contributions and follow a conservative financial behavior (Hirigoyen, 1985). As a result, financial independence is likely to limit the amount of internationalization knowledge and hence internationalization of small and medium family firms.

1.3.2. The human dimension of independence orientation

The pursuit of independence inhibits internationalization from the human point of view. The family firm adhering completely to the principle of managerial independence is limited quantitatively and qualitatively by the lack of human resources. Indeed, trying to avoid loss of control, family management tends to limit external managerial implication even it would be valuable to undertake international activities. To justify the customary recruitment of family directors and managers, the literature speaks about paternalist management and nepotism characteristics of the traditional family firm. Welsch (1996) observes that when the family firm makes a decision relating to its human resources, it is more influenced by family values and personality issues more than by a standardized set of performance and competence indicators. The altruism characterizing the owner-manager, generally the father or head of the family, implies a feeling of natural right among members of family. The owner-manager is thus incited to make use of firm resources to provide employment and other privileges to the family members (Schulze et al., 2001). Dunn (1995) indicates a critical consequence of this behavior. Indeed, the pursuit of the objective of preferential employment of family members may often signify the hiring of sub-optimal employees. Besides, the analysis of Harris et al. (1994) shows that the rigidities of the family firm, when it is about change of paradigm, are primarily due to the sclerosis to the human element:

- Family firm privileges internal succession, which is one of its main goals, and devotes the principle of loyalty, whereas new paradigms are likely to come from outside employees or management,

- Internally trained successors have weak external experience whereas new paradigms are likely to emerge from the variety of personal experiences,

- Heir of the entrepreneur can suffer from a lack of self-confidence whereas the possibility of emergence of new paradigms generally requires a great confidence in its personal judgment.

Another characteristic of family firms is to be emphasized. Indeed, this type of organization is known to be loyal i.e. seeking to keep the same employees for long periods. According to Miller et al. (2003), the same policies of recruitment and promotion, for example, are implemented at the profit of the same people. The absence of recruitment implies, however, an ageing of human resources and management in particular (Jenster and Malone, 1991).

Overall, the prerequisite in external competences is explained by the contribution in knowledge resources that outsiders can offer. Particularly with internationalization, they constitute a privileged source of market-specific knowledge. Despite the availability of increasingly powerful means of communication, moreover, delegation of responsibilities remains necessary because of the geographical distance.

In sum, human independence, implying exclusively internal recruitment and responsibility transfer, has a notable negative impact on the knowledge base of internationalizing small and medium family firm.

1.3.3. The relational dimension of independence orientation: co-operation and economic networks

Gray (1995) observes that owner-managers of small firms adhere to an organizational culture impregnated by individualism and anti-participation. The potential attenuation of independence constitutes a short or long term threat explaining probably the weak co-operative orientation of family SME. Indeed, the co-operation contains a dynamics which can make evolve the co-operation to a relation of global dependence. In fact, the attenuation of the independence, initially limited to the only field of agreement, would be extended to the entire firm (Adam-Ledunois and Le Vigoureux, 1998). Another explanation of the weak organizational networking of family SME can be induced from the explanations of the network approach. Belonging to a network implies, indeed, acceptance of the external influence. The position of a firm within its network can influence and is also influenced by expectations of other actors as for the way it should behave and interact with other organizations (Johanson and Mattson, 1988). Consequently, the position occupied by a firm, even if it permits access to new and valuable resources, relations and markets, is constraining because it shapes its role and relations with the other firms.

According to some authors, when they cooperate, family firms would choose their similar i.e. other family firms. Indeed, pursuing the same principles, in particular independence, and having a comparable size, they would not constitute a threat to independence^{vi}. In summary, family SME exhibits a weak co-operative orientation and a disinclination to integrate economic networks (Donckels and Fröhlich, 1991). Consequently, it is likely to develop a poor knowledge base since the role of the network can be crucial at least on three levels. First, through its implication in a network, a firm can develop a high

awareness of opportunities and threats pertaining to its activities since it is strongly exposed to environment. Second, its decisions and actions (concerning strategies to be adopted, for example) can be founded on an imitation of other more experienced actors of the network. Finally, the network allows a direct transfer of knowledge between participants.

In sum, we can argue that the influence of relational independence on the development of internationalization knowledge is negative.

H3: Independence orientation negatively influences internationalization knowledge.

1.4. Social networking

The network orientation of the owner-manager and his family is the last variable influencing the process of development of internationalization knowledge. This orientation is to be distinguished from organizational networking analyzed in the preceding section. The family firm shows a weak cooperative orientation in the sense of the pursuit of common objectives with an economic partner but a strong orientation toward social networking. It favors social relationships to economic ones that risk alienating its decision-making independence. The role of social networking in development of knowledge is crucial. Overall, networking was defined as an organizational means aiming to strengthen entrepreneurial processes. Yli-Renko, Autio and Tontti (2002) observe, in addition, that internal and external social capital influence acquisition and creation of knowledge guiding the international development of technological-intensive new ventures. The network approach of internationalization (Johanson and Mattson, 1988), even if it concerns organizational networks, stresses the seminal role of network orientation as for the development of knowledge during internationalization. Transposing this reasoning within the framework of social networks, social networking appears to be much important for the initiation and consolidation of international activities of family SME. In total, social networking influences positively the amount of internationalization knowledge of family SME.

Even if a lot of research analyzes the role of personal networks as a support in period of crises, the way in which social network functions and especially with respect to internationalization is still unexplained. We argue that the role of networking is to be stressed at least on two levels. Initially, this orientation plays a valuable role for the trigger of

international activities. Then, the network of personal and family relations contributes to the choices taken as regards markets to penetrate and entry modes to adopt.

1.4.1. Role of the social networking for the initiation of internationalization

The social network constitutes a competitive advantage for SME during its internationalization. Watkins (2000) find, for example, that Indian firms (up to 99 % under family control) are favored compared to firms belonging to countries where community and family relations values are not significant. The author explains that social network i.e. personal contacts established through family, friends and close relations and also the rooting of the firm in a community, is the main factor pushing the majority of studied firms to internationalize. Likewise, Dibben and Harris (2001) argue that social ties are the key trigger of international operations as the management would generally seek to establish durable relations and assigns a minor importance to short-term transactions. Yeung (2000) illustrates the economic potential allowed through personal and familial relations. He describes the case of a Chinese family firm whose international growth was done in particular through these relations. Social networking was not only the fact of the owner-manager but also of the entire family interacting with another family firm established in another country of the region. These two families, having lived experiences together and having a shared past, decided to initiate a business trans-border relation and found the essential complementarities to live this relation and to make it durable. The trust which exists through purely human relations (at the beginning) is thus used to propel a business relation.

The family firm relies enormously on its family relations in the broad sense of the term during its internationalization. The members of the family either assigned abroad or already present on the foreign markets form “an internationally extended family” (Fan, 1998) able to mobilize resources and especially knowledge of markets to conquer. This knowledge permits to reduce uncertainty (Johanson and Vahlne, 1977) because the social ties established abroad are more capable to evaluate opportunities and risks, and manage and govern effectively the activities. Overall, belonging to an ethnic community constitutes an advantage for internationalizing firms and in particular for family SME. Solberg (2001) evokes Jewish tradesmen established during centuries in various areas of the world as well as Indian or Chinese and Pakistani migrations during the second half of the last century as many factors having allowed the opening of many international trade routes (Solberg, 2001). In fact, the

cultural proximity, natural honesty and the confidence shared between people of the same ethnic group reduce uncertainty inherent to commercial transactions.

1.4.2. Social networking and international strategic choices

Personal networks (strong and weak ties^{vii}) are strategically important to the internationalizing firm. Their number and quality determine the choice capacity of the firm. The importance of these relations must be emphasized at least for two aspects of international strategy: the choice of target country and the choice of entry mode.

Choice of target country

Social networks play a significant role in the choice of the country where efforts of internationalization will be directed. This choice can be made according to the relations established in this country. Initially, the family firm can target a particular country at the instigation of members of its network present on this market. Sometimes, between two alternative markets, the firm will choose that where it holds a personal network because of the best knowledge of country these ties permit. In addition, family firm may want to assign its relations established in this country to the management and governance of local operations. Gallo and Sveen (1996) indicate that the existence of individuals belonging to the family, in the broad sense of the term, in foreign countries would facilitate the establishment of business relations with these countries as responsibilities could be assigned to them. A last factor pushing the family firm to choose a specific country reveals the subjective nature of this decision since the owner-family may want simply to invest in his country of origin or "do something for the country". Okoroafo (1999) notes indeed that ethnic and racial relations appear to affect choices of country of location of internationalizing family firms.

Another significant aspect has to be emphasized. The literature pertaining to "the immigrant effect" suggests that immigrants originating from a particular host market constitute a "bridge" between the foreign firm and this market. Immigrants often have a significant knowledge of their country of origin and understand profoundly the market culture. The results of certain studies imply that the immigrant effect could be regarded as a localization endowment for an internationalizing firm.

Choice of entry modes

The social ties can also influence the choice of entry modes on a specific market. Initially, through the counsel of its relations established on a market and holding an intimate knowledge of its functioning, the firm can choose a specific mode of penetration. On certain markets, these social ties are crucial because they permit to introduce the firm into the local business networks. Without the adequate contacts, this introduction would be difficult and even impossible in some markets (Ellis, 2000). Particularly to the family firm, a supplementary factor needs to be underlined. This organization would be inclined to privilege high control entry modes via direct investment in order to guarantee the implication of its relations in the business (family, friends of childhood). In fact, weak control entry modes require less control, administration and management and therefore do not allow a strong implication of the social ties. Consequently, the role of social ties proves to be more significant in the case of a penetration through direct investment than in case of export operations, since this last procedure implies a less commitment of resources and requires in particular less activity of information search and internalization. Finally, when the family wishes to involve or "do something" with its local partner, it would choose the co-operative modes such as alliances with this partner.

H4: Social networking positively influences internationalization knowledge.

2. METHODOLOGY AND EMPIRICAL RESULTS

2.1. Methodology

Through a questionnaire, we tested the hypotheses of our model. Prior to this step, we carried out interviews for an end of validation of some items forming the questionnaire. The measurement of constructs is based on the one hand on scales existing in the literature and on the other hand on the development of new scales. Indeed, several empirical studies were first used to build the study questionnaire. Besides, the new scales were developed through the literature review and an exploratory study. Concerning internationalization knowledge, we adopt a posture which considers knowledge as a measurable construct. Indeed, many authors

note that one of the weaknesses of the knowledge-based approaches is the difficulty if not the impossibility of the measurement of knowledge.

The questionnaire was pre-tested in order to check for the validity of content. All the items, except for the scale of internationalization knowledge (Likert scale of 3 points), were evaluated on a Likert scale of 5 points. The collection of data by questionnaire was carried out in two stages. Indeed, a year after the first sending, the questionnaire was re-examined and revised. An improved version was tested and sent to the sample enterprises.

The strategy of collection of the responses was carried out exclusively through Internet. Two strategies of constitution of the sample were adopted, the first selecting *a priori* the relevant firms, the second carrying out *a posteriori* selection. First, a sample was constituted through the electronic data bases Diane and Kompass 1999 and the French “Atlas of groups and financial links” 2001. The obtained sample includes 764 family business groups defined according to two criteria: control of the capital and involvement in high management. The second adopted approach is comparable to the one used by Luostarinen and Hellman (1995). The authors start from a sample of internationalized Finnish firms and proceed to a screening in order to isolate two sub-sets: family firms and non-family firms. A second sample was thus formed on the basis various sources (Kompass, Associations of exporting firms, CCI French exporting firms files).

Finally, the study was based on 118 firms belonging to various industries. The age of the firms of the sample varies between 5 and 254 years with an average is 54,8 years. More than 58% of the firms are controlled mainly by the family and approximately 36% of the firms are still directed by their founders.

After evaluating the reliability and validity of the items through exploratory and confirmatory factor analysis, the model was tested through structural equation modeling (LISREL). Several iterations were carried out in order to obtain the best interpretable model. Refinements were operated on the basis of initial theoretical construction and 5 various models were compared.

2.2. Results

Initially, the evaluation of the reliability of the items was carried out. It is a needed condition preceding the stage of the assessment of the model. Indeed, the statistical method

adopted for the explanatory analysis, structural models (LISREL), must first ascertain the relevance of the measurement model.

2.2.1. The purification of the scales

This analysis is based first on “conventional” statistical analysis of psychometric scales purification. Then, a confirmatory analysis grounded on structural equations is used. Indeed, the structure of the scales resulting from the first series of analyzes has to be verified through the confirmatory evaluation.

Results of the exploratory factorial analysis

Several exploratory factor analyses were carried out in order to obtain stable and interpretable structures from the initial scales. A recapitulation of the retained scales at the end of this phase is shown in the following table (Table 1).

Table 1: Summary of the measurement scales

Dimension	Number of items	Scale/Under-scale	Retained items	Cronbach's Alpha
Conservatism	8	(CONSE)	5	0,848
Independence	10	(IndRes) Resource Independence	2	0,703
		(InDec) Decisional Independence	4	0,878
Networking	7	(RESEAU)	4	0,906
Internationalization Knowledge	17	(CI)	15	0,949
Degree of internationalization	4	(DOI)	4	0,772

Confirmatory factorial analysis

Confirmatory factor analyses were carried out in order to validate the factorial structure of each construct of the model, except for the internationalization knowledge. Indeed, we choose to use a single indicator for this variable during the explanatory phase of the study. Therefore, there is no need to carry out a CFA on the basis of the retained indicators for this variable. Essentially, the aggregation of the 15 items contributing to this construct was made necessary because of the strong correlations between them. However, the use of a single indicator in structural equations models is likely to imply identification problems (Roussel and ali., 2002). Accordingly, for the assessment of the causal model, we had to fix the error variance of the single indicator in order to identify the model.

The following table synthesizes the obtained global fit indices for the first 3 scales. Overall, the obtained values meet the commonly admitted standards and thus the measurement models are accepted.

Table 2: Global fit indices

		Conservatism	Independence	Networking
Absolute	χ^2	χ^2 (ddl=4): 4.46 (P = 0.34726)	χ^2 (ddl=6): 17,69 (P = 0.007)	χ^2 (ddl=1): 1,54 (P = 0.22)
	GFI	0,99	0,95	0,99
	AGFI	0,95	0,83	0,94
	RMR	0,018	0,031	0,0062
	RMSEA	0,031	0,13	0,067
Incremental	NFI	0,95	0,97	1
	CFI	1	0,98	1
Parsimony	χ^2 /ddl	1,115	2,948	1,54
	PNFI	0,38	0,39	0,17

For the variable “degree of internationalization”, the fit indices are not presented due to the fact that the model is saturated. The χ^2 of the model is null.

The computation of the indices of reliability and validity for the various scales is summarized in table 3.

Table 3: Measurement model fit

		CONS	IndRes	InDec	Networking	DOI
<i>Reliability</i>	Ksi Rhô	0.866	0,7643	0,8759	0,9229	0,857
<i>Convergent validity</i>	Rhô vc (1)	0.566	0,6218	0,641	0,7519	0,6673
	Rhô vc (2)	0.571	0,6207	0,6388	0,7504	0,6668

The literature assumes good reliability if the value of Rhô is higher than 0.7 or 0.8. Both “Rhô” of convergent validity are good if they are higher than 0.5. Here, all the retained scales satisfy these conditions.

The scale of independence orientation, divided into two dimensions of resource independence and decision independence, has to prove discriminating validity. An analysis making a comparison between the constrained and free models confirm the discriminating validity of the two sub-scales.

2.2.2. Causal analysis

Contrarily to the confirmatory factor analysis, the causal analysis is carried out on the basis of the variance-covariances matrix. The process of definition, comparison and choice of models was done mainly on the basis of the criterion of the χ^2 value which, despite its disadvantages, allows obtaining a rapid appreciation of the quality of fit. Furthermore, an approach needed to reduce the risk of under-identification is adopted. We had to fix to one the first parameter, i.e. the first loading of the first indicator of a latent variable. This action is necessary for the dependant variables contrarily to the independent ones.

Several iterations were carried out in order to obtain to best model. Refinements were operated on the basis of initial theoretical construction and 5 various models were compared.

<p>M1 : Relations are those hypothesized in the theoretical model</p> <p>M2 : Links between variables CONSE and IndRes and InDec are added</p> <p>M3: We order the variables in a chain. Schematically, the model is: CONSE → InDec → IndRes → CI → DOI with, of course, the influence of RESEAU (Networking) on Internationalization knowledge.</p> <p>M4: A link between IndRes and DOI instead of CI is established. In addition, we re-establish the link between CONSE and IK.</p> <p>M5: In the model M2, we broke the link between CONSE and CI and we add a relation between CONSE and</p>

A description of the 5 models is made in table 4. The comparison of the fit indices of the different models as well as the total percentage of explained variance permit to choose the most parsimonious model and best adjusted with the empirical data.

Table 4: Comparison of fit indices between tested models

	Fit indicator	M1	M2	M3	M4	M5
Absolute	χ^2	111,09 (P=0,98791)	108,45 (P=0,9926)	92,22 (P=0,999)	75,37 (P=1,00)	74,85 (P=1,00)
	ddl	147	147	148	147	147
	GFI	0,91	0,91	0,92	0,94	0,94
	AGFI	0,88	0,89	0,9	0,92	0,92
	SRMR	0,12	0,12	0,081	0,064	0,064
Incremental	NFI	0,75	0,76	0,8	0,84	0,84
	CFI	1	1	1	1	1
Parsimony	χ^2 /ddl	0,7557	0,7377	0,623	0,5127	0,509
	PNFI	0,64	0,65	0,69	0,72	0,72
Explicative power	R ² Sum (CI and DOI)	0,91	1	0,71	0,99	1,01
	R ² Sum	0,91	1,48	2,07	2,15	2,21

The table shows that model M5 exhibits a better fit with the empirical data even if its quality is very close to that of model M4. Finally, we adopt M5 as a final model which would be subject to interpretation.

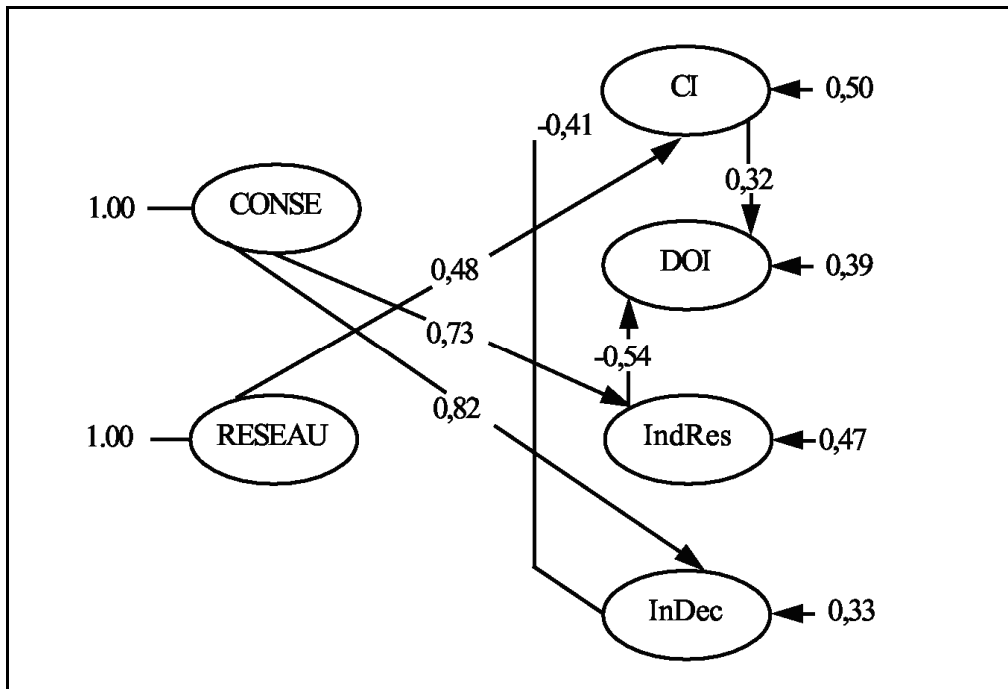

Figure 2: Model M5 – diagram of the linear relations (standardized parameters)

The examination of the results allows suggesting that as for the studied sample:

- Internationalization knowledge positively influences the degree of internationalization of the firm (H1 confirmed).
- The conservatism of family SME does not directly influence the level of internationalization knowledge. The influence of conservatism on internationalization knowledge is exerted only through the decisional dimension of independence orientation (H2 partially confirmed).
- The independence orientation of family SME, then with its two dimensions simultaneously (decisional and resource independence), does not significantly influence internationalization knowledge. Contrary to decisional independence which influences indirectly the degree of internationalization (thanks to the intermediation of internationalization knowledge), resource independence influences directly the dependant variable. The mediation of internationalization knowledge of is thus not totally proven (H3 partially confirmed)
- Social networking positively influences the amount of internationalization knowledge (H4 confirmed).

Table 5: M5 model - Estimates of the parameters of the causal relations

Measurement model							Structural model		
	Item	Lambda	T	Error variance	T	R2	Parameter	Estimate	T
CI	conin	1	-	3,35	-	0,97	CI ← NETWORK	5,31	5,02 (1,06)
DOI	Zcaetran	1	-	1,36	6,05 (0,22)	0,31	CI ← InDec	-4,59	-3,44 (1,33)
	Zeffetra	1,1	4,07 (0,27)	1,23	5,49 (0,22)	0,37	DOI ← CI	0,02	2,62 (0,01)
	Zactfetr	0,96	3,81 (0,25)	1,41	6,23 (0,23)	0,29	DOI ← IndRes	-0,05	-3,21 (0,16)
CONSE	cons1	0,8	5,88 (0,14)	1,35	6,56 (0,21)	0,32	InDec ← CONSE	0,82	3,52 (0,23)
	cons2	0,79	5,76 (0,14)	1,38	6,61 (0,21)	0,31	IndRes ← CONSE	0,73	3,23 (0,22)
	cons3	0,85	6,30 (0,14)	1,27	6,34 (0,20)	0,36	R²		
	cons7	0,62	4,36 (0,14)	1,62	7,12 (0,23)	0,19	R ² (CI) = 0,40		
	cons8	0,71	5,09 (0,14)	1,5	6,89 (0,22)	0,25	R ² (DOI) = 0,61		
IndRes	ind2	0,64	3,40 (0,19)	1,59	6,62 (0,24)	0,2	R ² (IndRes) = 0,53		
	ind4	0,91	3,86 (0,23)	1,18	4,72 (0,25)	0,41	R ² (InDec) = 0,67		
InDec	ind5	0,83	4,04 (0,21)	1,31	6,41 (0,20)	0,35	Disturbances		
	ind6	0,81	3,97 (0,20)	1,35	6,52 (0,21)	0,32	CI	74,5	5,97 (12,48)
	ind7	0,81	4,00 (0,20)	1,34	6,48 (0,21)	0,33	DOI	0,24	1,76 (0,14)
	ind8	0,89	4,15 (0,21)	1,21	6,11 (0,20)	0,39	IndRes	0,47	
NETWORK	netw4	0,7	4,94 (0,14)	1,51	6,81 (0,22)	0,25	InDec	0,33	
	netw5	1	7,33 (0,14)	1,01	5,04 (0,20)	0,5			
	netw6	0,88	6,37 (0,14)	1,23	6,00 (0,20)	0,39			
	netw7	0,93	6,75 (0,14)	1,14	5,67 (0,20)	0,43			

In sum, the data allows to make the following observations:

- Firstly, the development of knowledge during the internationalization of family SME is subject to the influence of decisional independence. Fearing the opening of its capital to external partners and avoiding capitalistic involvement of non-family management, the family SME commits itself to a rigid strategic paradigm preventing from the development of a significant international competence. Indeed, the cognitive contribution of outsiders to the vision and choices of the firm is crucial. In addition, trying to avoid external interferences in decision-making through the devotion to internal recruitment, this entity could be handicapped in its development by the lack of fresh and new knowledge and external points of view.

- Secondly, the model shows that decisional independence is influenced (significantly and more than resource independence) by conservatism. This is not surprising since we can

conceive these two variables, i.e. conservatism and independence orientation, as located at different hierarchical levels, the first constituting a context in which the second is exerted. The independence orientation can be regarded as the manifest expression of the firm's conservatism. Besides, the influence of conservatism on the resource dimension of independence is not to be ignored even if it is not significant out of the bivariate statistics (correlations between the two constructs). In sum, when the influence of conservatism is not exerted directly through decisional independence, it relies on resource independence in the chain connecting it to internationalization knowledge. Conceptually, the conservatism of the firm, through its "government" and "risk" dimensions, logically implies an attitude of avoidance of the outside and a fear of loss of control. This could be understood since the firm constitutes the wealth to be transmitted to the next generations. Consequently, conservatism and the resulting independence orientation might cause a certain prejudice to the firm's growth. As Eriksson and al. explain (2000), the weak variation which could result from conservatism implies a weak international exposition and exerts a negative influence on the development of internationalization knowledge and the two dimensions of market knowledge (operational and institutional).

- Thirdly, as postulated, social networking is significantly and positively associated with internationalization knowledge. The reason underlying this orientation is the access to rare and crucial resources needed for a specific strategic direction. The family firm privileges the establishment of social networks more than formal economic networks. Therefore, initiation, development and maintenance of social ties are crucial for the acquisition and development of the firm's knowledge base. In particular, the role of networking during internationalization is significant. The literature stresses the strategic importance of knowledge originating from outside the organization rather than internal knowledge which could exhibit redundancy and weak adequacy to the external requirements. Therefore, profiting from trust and confidentiality guaranteed by its partners and social relations, the family can devise an entire strategy of networking for ends of development and acquisition of knowledge.

The basic postulate on which all our models are constructed is the fact that internationalization knowledge is preceding i.e. constituting the cause of internationalization. All tested models confirm this relation. Even if this postulate is restrictive because the degree of internationalization can depend on other variables, it is obvious that internationalization knowledge plays a crucial role in the international development of SME. This logic is founded on an assumption of linearity between internationalization knowledge and degree of

internationalization. Currently, this argument is being challenged. For example, Petersen and ali. (2002) argue that knowledge is not only beneficial to the internationalization and that in certain circumstances more knowledge might limit firm's internationalization.

3. Implications: specificities of learning and knowledge development within family SME

The characteristics of conservatism, independence orientation and networking strongly influence the processes of organizational learning and knowledge development within family SME. The justification of this specificity is due to the fact that this entity shows:

- First, the overlapping of "family" and "company" spheres: the family sphere realizes a unique contribution because it constitutes a supplementary source of knowledge inbound to the company compared with a firm without family involvement,
- Then, the frequency of the exchanges within the organization: the processes of exchange of piece of information and knowledge take place not only in the organizational context but also and especially in the family context. The family meetings constitute, for example, supplementary occasions of exchange and sharing of knowledge.

Two consequences are to be analyzed. In this entity, the activities of learning and development of strategic knowledge are centered on the family encouraging causal ambiguity. The second phenomenon is that within the family, knowledge is preserved and perpetuated through a process of intergenerational transfer.

3.1. The family in the heart of the processes of knowledge development

The analysis of the conservatism and independence orientation raises questions about the efficacy of the organizational memory within the family firm. What are the mechanisms of preservation of knowledge within the family firm? This organization runs specific risks because of the singularity of the mechanisms of knowledge management.

The typical paternalistic management of the family firm which implies a centralization of power and decision allows obviously the flexibility of the organization. But, at the same time, it influences the processes of learning and development of knowledge which are henceforth centered on the family sphere. The family holds the monopoly of the acquisition, sharing and transfer of knowledge within the organization. Taking advantage of its rights of decision and control, the family dominates the management of knowledge. Overall, internalization of strategic knowledge would be primarily the fact of the owner-manager and his family. Then, the family firm shows a weak socialization of strategic knowledge out of the family circle. In spite of the contribution they provide to the development of the knowledge base, outsiders are likely to be excluded. The essence of knowledge, i.e. its tacit component, being mainly acquired by the family members, there is a tendency to limit its diffusion. There would be, consequently, a conscious will of the management of not engaging a process of externalization. Firms whose “familiness” (Habbershon and Williams, 1999) is weak would behave differently and tolerate sharing activities of strategic knowledge management with outsiders. This sharing should have a beneficial effect on the construction and development of the organization’s knowledge base because of the variety and richness of externals’ contributions.

Therefore, because of its founding natural characteristics, the family firm nurture mechanisms which reinforce the causal ambiguity (Nelson and Winter, 1982) by strengthening the voluntary effort to avoid either a too fast imitation or the loss of knowledge-based resources if the individual or the group holding it leave the organization (Arrégle, 1995). The family firm is quite inclined to privilege mechanisms of protection of knowledge such as:

- Strengthening the tacit aspect and avoiding formalizing,
- Voluntarily maintaining the complexity.

In short, family firms show an inclination to concentrate the processes of knowledge management around its tacit dimension by encouraging its formation contrarily to the explicit element.

However the weak externalization of knowledge coupled with the avoidance of sharing outside the family causes serious risks. First, an obvious risk of deterioration is present because of the weak importance of the organizational protection mechanisms and the strong reliance on individual memory. Particularly to Chinese family firms, Tsang (1999) observes that they can be classified as "the one-man institution" within Shrivastava’s (1983) typology. The owner is the man “who is knowledgeable about all aspects of the business,

(and) is the key broker of organizational knowledge. He acts as a filter and controls the flow of information to and from every important manager” (Shrivastava, 1983, p. 20). In sum, even if the family firm exhibits a weak erosion of knowledge because of the weak rotation of directors, an important risk is inherent to the eventuality of a sudden loss of a key member of the family and the company. The organizational memory of the family firm is fragile. Thus, even if operational knowledge gained from the daily activities and profiting to the operational management team is better protected from extinction, the strategic knowledge held primarily by the owner-manager and the members of his family is endangered. Moreover, we suggest a risk of erosion of knowledge due to the fragmentation caused by successions that do not preserve the unity of the firm. There is indeed a risk of "fragmentation" of the strategic knowledge if the company is shared between the potential successors. This risk would be less pronounced if a prior sharing of knowledge with outside directors had been engaged.

In summary, in order to protect experience and knowledge acquired from its activities, which could be lost with the departure of the person or the team holding it, the organization have to set up mechanisms of sharing and diffusion. The solving of the problems of diffusion and transfer of knowledge can, in the case of the family firm, be founded on a specific process: the intergenerational transfer of knowledge.

3.2. Intergenerational transfer of knowledge: means of knowledge preservation

Mechanisms inciting to intergenerational transfer of knowledge must be set up because of the negative impact of conservatism and independence orientation on knowledge and due to the fragility of family firm organizational memory. The process of transfer of knowledge through generations is thus crucial to be able to maintain the competitive advantage of the firm. It is important to operate a distinction between the strategic knowledge on one hand and the operational knowledge, on the other hand. Strategic knowledge is the competence generally held by the management implied in decision-making. Operational knowledge is that used or acquired by employees confronted to daily operational management. In fact, the modes of appropriation of these types of knowledge are different. Ward and Aronoff (1996) make a similar distinction between the acquisition of business knowledge and the acquisition of leadership capacities. Initially, the successor has to be able to acquire and use the operational knowledge which encompasses the founding know-how of the company. But the learning of the successor is more importantly about strategic knowledge

stemming from the experience of direction acquired by the predecessors. It is a question of passing on not only the content of knowledge founding the advantage of the firm but the way of operating and of running business. Indeed, the transfer concerns a managerial competence of direction, in our case relative in particular to the international operations of the firm.

Competence being a competence in action (Le Boterf, 1994), the successor has to show competence i.e. that he can act with competence. Not subject to be formalized, the most suitable strategy of transfer of strategic knowledge would be observation that young managers make supplemented by a process of action learning. The predecessor has to delegate to the potential successor increasingly significant missions. Thus, the successor has to learn from his actions, discoveries and interactions and also from his experiences and the observation of his peers (Hugron and Boiteux, 1998). The learning of the successor is grounded mainly on an intense process of socialization. Indeed, strategic knowledge is shared within the family management and communicated to potential successors. In sum, transmission is less about content of knowledge than a methodology of problem solving.

Intergenerational transfer of knowledge within family firms is nevertheless problematic. Cabrera-Suarez et al. (2001) identify four obstacles against knowledge transfer:

- Characteristics of transferred knowledge, its causal ambiguity,
- Characteristics of the source (the predecessor) and especially its lack of motivation,
- Characteristics of the target (the successor): its absence of motivation, limited absorptive and retention capacity,
- Context of the transfer: sterile organizational context or difficult relations between the predecessor and the successor.

Conclusion

To our knowledge, this research is the first of its kind to examine the knowledge-based processes in family businesses. Despite its value, it has many weaknesses. A major weakness is the absence of a synchronic approach as the dependant and independent variables are measured at the same moment. A more longitudinal approach would be valuable to analyze the causal relationships between the independent variables and internationalization knowledge and degree of internationalization. A second limitation is that the characteristics of the sample may limit the generalizability of the results.

The fact that some other potentially important variables influencing knowledge development during internationalization are omitted is theoretically criticizable. Indeed, several family SME specific variables could bring a complementary understanding to the internationalization process: age of the firm, controlling generation, governance mechanisms (such as the reliance on a board of directors), or technological intensity, etc. Other factors such as perceptions of managers about internationalization benefits, or resources controlled by the firm constitute important variables that have to be taken into account in a future research. Besides, our research does not account for some external variables explaining knowledge development and internationalization degree. In that, our model shows the major limit of its exclusive focusing on knowledge as a determinant of internationalization degree. Many other factors are potentially important in explaining this phenomenon (Sullivan and Bauerschmidt, 1990). For instance, the size of the foreign market is an important explanatory factor of internationalization knowledge acquisition.

Even if conservative behavior can be justified in case of extreme uncertainties or abnormal risks weighing on the economic environment, it is, nevertheless, criticizable. Conservatism establishes an attitude and a thinking hostile to renewal. Yet, the theories of organizational learning stress that the commitment of management team is an essential condition to the trigger and success of internationalization. A strong and committed management is necessary in order to motivate the organization and to help it overcome the difficulties. Since human capital of the family firms shows positive characteristics of strong commitment, cordial, friendly and close ties, and the potential allowing for a deep specific tacit knowledge, we can suppose that this organization can be favored (compared to its counterparts) during organizational learning. A condition is that family SME could draw from its human resources, the necessary commitment to struggle against the forces of conservatism. In order to obtain human resources commitment, it is necessary to involve all levels of direction and management during the reflection and planning of international activities and to sensitize them to the importance of their implication for the success of this orientation. The presence of a strong personality (generally the founder or the owner-manager) who motivates the employees and bring them together to achieve the organizational goals is essential. In particular, the owner-manager should realize the benefits of internationalization, supports and encourages the process. He also could transmit the knowledge accumulated through his personal commitment to other family members (Tsang, 1999). Thus, in spite of a rigid organizational structure, the owner-manager can lead his organization towards flexibility and

change. More generally, the organization must change posture and adopt a positive attitude and open-mindedness.

In addition, family SME needs to tolerate an attenuation of its independence on the financial and human plans. The policy of conservation of financial independence can constitute a significant barrier to future growth and internationalization because the internal financing can be insufficient. Indeed, financial needs appear during the phases of commercial prospecting, establishment and become more important with the increase in working capital requirement (Hirigoyen, 1995). Internationalization of the family firm thus depends on its tolerance to external financial intervention as that of local investors or specialized venture capitalists (Gallo et al., 2002). The recourse to venture capital financing would avoid, indeed, the increase in risk normally due to increase in debt level. Either, the firm should not avoid turning to banking debt but should benefit from the various formulas of loans designed for exporting firms. Studying family firms committed in international strategic alliances, Gallo et al. (2002) indicate that they become less reticent to the opening of capital as the need for investing resources in order to accelerate internationalization becomes urgent and the experience of management as for the sharing and conservation of power in alliances accumulate. Opening up, the family firm can facilitate its access to capital by the institutionalization of appropriate governance mechanisms. In order to ensure that aspirations of capital suppliers, on the one hand, and those of the family, on the other hand, are taken into account simultaneously for decision-making and pursuit of organizational goals, Davis et al. (2000) recommend a dual structuring of organizational governance processes. Family SME must, in addition, overcome its human independence and seek outside for these valuable resources. This can be done through a process of "familization" i.e. incorporation to the dominant family of certain external elements through alliances and marriages. Justified by the quality of the relations established with those people and by their honesty and value in the eyes of the family, these processes are very interesting. Indeed, they indicate a relative broadmindedness and an attenuation of the independence attitude. Also, family SME can open up through its natural tendency to networking which could allow for an intense exposure to international economic environment.

Schematically, not only small and medium family firms internalize and develop weak knowledge but they also externalize and share a little knowledge. The risks associated with this knowledge strategy are the possible extinction of valuable knowledge. Therefore, the process of knowledge transfer through generations would be crucial to the family SME in order to be able to maintain its competitive advantage. In addition, if know-how is the core

resource underlying this competitive advantage then its "transferability" will determine the period during which its holder will obtain returns (Spender, 1996). In sum, small and medium family firms have to implement a deliberate strategy of knowledge preservation through, for instance, externalization of *articulable* tacit knowledge and socialization of non *articulable* knowledge with external managers (Nonaka and Takeuchi, 1998). This strategy is not optional but could be vital to ensure the survival of these firms.

References

- Adam-Ledunois, S. and Le Vigoureux, F. (1998), " Entreprises moyennes : l'indépendance en question ", Paper presented at CIFEPME, Metz, 1998.
- Arrègle, J-L. (1995), " Le savoir et l'approche Resource-based : une ressource et une compétence ", Revue Française de Gestion, Septembre-Octobre 1995, pp. 84-94.
- Astrachan, J. and Kolenko, T. (1996). " A Neglected Factor Explaining Family Business Success: Human Resource Practice " in Beckhard R. (Ed.), *The Best of FBR: A Celebration*, Boston, Mass.: Family Firm Institute, pp. 119-134.
- Astrachan, J., Klein, S. and Smyrnios, K. (2002), " The F-PEC Scale of Family Influence: A Proposal for Solving the Family Business Definition Problem ", Family Business Review, Vol. 15, n°1, March 2002, pp. 45-58.
- Autio, E., Sapienza, H. and Almeida, J. (2000), " Effects of Age at Entry, Knowledge Intensity and Imitability on International Growth ", Academy of Management Journal, Vol. 43, n°5, pp. 909-924.
- Basly, S. (2002), « L'internationalisation de l'entreprise familiale », in Hirigoyen G. and Caby J. (Ed.), *La gestion des entreprises familiales*, Economica, Paris, 2002.
- Basly, S. (2005), " Internationalization of family firms in a knowledge-based view ", Paper presented at the " Workshop on family firm management research ", Jönköping International Business School, Jönköping, Sweden, June 9-11, 2005.
- Basly, S. (2005), " L'internationalisation de la PME familiale: une analyse fondée sur l'apprentissage organisationnel et le développement de la connaissance ", Phd Thesis in Management Science, Université Montesquieu-Bordeaux 4, December 2005.
- Basly, S. (2006), " Propriété, décision et stratégie de l'entreprise familiale: une analyse théorique ", Paper presented at the AFFI International Conference (French Finance Association), June 26-27, 2006, Poitiers, France.
- Basly, S. (2006), " The internationalization of family SME: An organizational learning and knowledge development perspective ", Paper presented at the MMRC-ERA Conference (Modern Management Research in the Context of European Research Area), Kaunas, Lithuania, September 15-17, 2006.
- Basly, S. (2006), " L'internationalisation de la PME familiale : apprentissage organisationnel et développement de la connaissance ", Paper presented at the International Francophone Conference on Entrepreneurship and SME (CIFEPME) 2006, October, 25-27, 2006, Fribourg, Switzerland.

- Cabrera-Suarez, K., De Saa-Perez, P. and Garcia-Almeida, D. (2001), " The Succession Process from a Resource- and Knowledge-Based View of the Family Firm ", *Family Business review*, Vol. 14, n°1, pp. 37-48.
- Carlson, S. (1966), *International Business Research*, Uppsala: Acta Universitatis Upsaliensis.
- Charreaux, G. (2002), " Variations sur le thème : A la recherche de nouvelles fondations pour la finance et la gouvernance d'entreprise ", Research paper, Université de Bourgogne.
- Davis, P. (1983), " Realizing the potential of the family business ", *Organizational Dynamics*, 12, pp. 47-56.
- Davis, P., Pett, T. and Baskin, O. (2000), " Governance and Goal Formation Among Family Businesses: A Resource Dependency Perspective ", Research paper transmitted by the authors.
- Dibben, M. and Harris, S. (2001), " Social Relationships as a Precursor to International Business Exchange ", Paper presented at the 17th IMP Conference, Oslo, Norway, September 9-11 September 2001.
- Donckels, R. and Frohlich, E. (1991), " Are Family Businesses Really Different? European Experiences from STRATOS ", *Family Business Review*, Vol. 4, n° 2, summer 1991.
- Dunn, B. (1995), " Success themes in Scottish family businesses: Philosophies and practices through the generations ", *Family Business Review*, Vol. 8, n°1, pp. 17-28.
- Dyer, W. Jr. (1986), *Cultural change in family firms: anticipating and managing business and family transitions*, San Francisco, CA: Jossey-Bass.
- Ellis, P. (2000), " Social Ties and Foreign Market Entry ", *Journal of International Business Studies*, Vol. 31, n°3, pp. 443-469.
- Eriksson, K., Johanson, J., Majkgard, A. and Deo Sharma, D. (1997), " Experiential Knowledge and Cost in the Internationalization Process ", *Journal of International Business Studies*, Vol. 28, n°2, pp. 337-360.
- Eriksson, K., Johanson, J., Majkgard, A. and Deo Sharma, D. (2000), " Effect of Variation in Knowledge Accumulation in the Internationalization Process ", *International Studies of Management and Organization*, Vol. 30, n°1, pp. 26-44, 2000.
- Fan, Y-K. (1998), " Families in the 21st Century: The Economic Perspective ", *HKCER Letters*, Vol. 50, May 1998.
- Gallo, M. and Sveen, J. (1991), " Internationalizing the Family Business: Facilitating and Restraining Factors ", *Family Business Review*, Vol. 4, n°2, summer 1991.
- Gallo, M., Arino, A., Manez, I. and Cappuyns, K. (2002), " Internationalization via Strategic Alliances in Family Businesses ", Paper presented at the 13th FBN Conference, Helsinki, 2002.
- Granovetter, M. (1973), " The Strength of Weak Ties ", *American Journal of Sociology*, Vol. 78, pp. 1360-1380.
- Gray, C. (1995), " Managing Entrepreneurial Growth: A Question of Control? ", Paper presented at the 18th conference of the Institute of Small Business Affairs (National Small Firms Conference), University of Paisley, Scotland.
- Gudmundson, D., Hartman, E. and Tower, C. (1999), " Strategic Orientation: Differences between Family and Nonfamily Firms ", *Family Business Review*, Vol. XII, n°1, March 1999.
- Habbershon, T. and Williams, M. (1999), " A Resource-Based Framework for Assessing the Strategic Advantages of Family Firms ", *Family Business Review*, Vol. XII, n°1, March 1999.
- Hambrick, D., Geletkanycz, M. and Fredrickson, J. (1993), " Executive Commitment to the *Status Quo*: Some Tests of its Determinants ", *Strategic Management Journal* 14, pp. 401-418.

- Harris, D., Martinez, J. and Ward, J. (1994), " Is Strategy Different for the Family-Owned Business? ", *Family Business Review*, Vol. VII, n°2, summer 1994.
- Hirigoyen, G. (1985), " Les implications de la spécificité des comportements financiers des moyennes entreprises industrielles (M.E.I) familiales ", Research paper, IAE de Toulouse, n°35, september 1985.
- Hirigoyen, G. (1995), " Le financement des PME exportatrices en Europe ", in B. PRAS and A. BOUTIN (*Ed.*), *Les Euro-PMI*, Paris, Economica 1995.
- Hugron, P. and Boiteux, S. (1998), " La PME familiale mondiale : conséquence sur la relève ", Paper presented at the 4th International Francophone Congress on SME (CIFEPME).
- Jenster, P. and Malone, S. (1991), " Resting on your Laurels: The Plateauing of the Owner-manager ", Paper presented at the FBN conference, Barcelona, Spain.
- Johanson, J. and Mattsson, L-G. (1988), " Internationalization in Industrial systems-A Network Approach ", in P.J Buckley and N.G. Pervez (Ed.), *The Internationalization of the Firm : A Reader*, 1993.
- Johanson, J. and Vahlne, J-E. (1977), " The Internationalization Process of the Firm - A Model of Knowledge Development and Increasing Foreign Market Commitments ", *Journal of International Business Studies*, Vol. 18, n°1, pp. 23-32.
- King, S., Solomon, G. and Fernald, Jr. L. (2001), " Issues in Growing a Family Business: A Strategic Human Resource Model ", *Journal of Small Business Management*, Vol. 39, n°1, pp. 3-13.
- Knight, G. and Liesch, P. (2002), " Information Internalization in Internationalizing the Firm ", *Journal of Business Research*, Vol. 55, n°12, pp. 981-995.
- Le Boterf, G. (1994), *De la Compétence. Essai sur un attracteur étrange*, Paris, Editions d'Organisation, 1994.
- Litz, R. (1995), " The Family Business: Toward Definitional Clarity ", *Family Business Review*, Vol. 8, n°2, summer 1995.
- Melin, L. and Nordqvist, M. (2000), " Corporate Governance in Family Firms: The Role of Influential Actors and the strategic Arena ", Paper presented at the ICSB Conference, 2000, Brisbane, June 2000.
- Miller, D., Steier, L. and Le Breton-Miller, I. (2003), " Lost in Time: Intergenerational Succession, Change, and Failure in Family Business ", *Journal of Business Venturing* 18 (2003), pp. 513-531.
- Moloktos, L. (1991), " Change and Transition and Family Businesses ", Paper presented at the FBN conference, Barcelona, Spain.
- Mustakallio, M. and Autio, E. (2001), " Optimal Governance in Family Firms ", Paper presented at the Babson Entrepreneurship Conference.
- Mustakallio, M. and Autio, E. (2002), " Governance, Entrepreneurial Orientation and Growth in Family Firms ", Paper presented at the 13th FBN Conference, Helsinki, 2002.
- Myers, S. and Majluf, N. (1984), " Corporate Financing and Investment Decisions when Firms Have Information that Investors Do Not Have ", *Journal of Financial Economics* 13, pp. 187-221.
- Nelson, R. and Winter, S. (1982), *An Evolutionary Theory of Economic Change*, Cambridge: Belknap Press of Harvard University Press.
- Nonaka, I. and Takeuchi, H. (1998), " A Theory of the Firm's Knowledge-Creation Dynamics ", in Alfred D. Chandler, Jr., Peter Hagström and Örjan Sölvell,(Ed.), *The Dynamic Firm, The Role of Technology, Strategy, Organization, and Regions*, Oxford University Press, pp. 214-241.

- Okoroafo, S. (1999), " Internationalization of Family Businesses: Evidence from Northwest Ohio, USA ", *Family Business Review*, Vol. XXI, n°2, June 1999.
- Penrose E. (1959), *The Theory of the Growth of the Firm*, Oxford University Press, Third Edition (1995).
- Ranft, A. and O'Neill, H. (2001), " Board Composition and High-flying Founders: Hints of Trouble to Come? ", *The Academy of Management Executive*, Vol. 15, n°1, pp. 126-139.
- Salvato, C., Williams, M. and Habbershon, T. (2002), " Values and Competitive Advantage: The Cultural Determinants of Dynamic capabilities in Family Firms ", Paper presented at the 13th FBN Conference, Helsinki, 2002.
- Sanders, W. and Carpenter, M. (1998), " Internationalization and Firm Governance: The Roles of CEO Compensation, Top Team Composition and Board Structure ", *Academy of Management Journal*, Vol. 41, n°2, 1998, pp. 158-178.
- Schulze, W., Lubatkin, M. and Dino, R. (2003), " Exploring the Agency Consequences of Ownership Dispersion Among the Directors of Private Family Firms ", *Academy of Management Journal*, Vol. 46, n°2, pp. 179-194.
- Schulze, W., Lubatkin, M., Dino, R. and Buchholtz, A. (2001), " Agency Relationships in Family Firms: Theory and Evidence ", *Organization Science*, Vol. 12, n°2, March-April 2001, pp. 99-116.
- Schwartz, B. and Barnes, L. (1991), " Outside Boards and Family Businesses: Another Look ", *Family Business Review*, Vol. 4, n°3, pp. 269-285.
- Shrivastava, P. (1983), " A typology of organizational learning systems ", *Journal of Management Studies*, 20 (1), pp. 7-28.
- Solberg, C. (2001), " Market Information and the Role of Networks in International Markets ", Paper presented at the 17th IMP Conference, Oslo, Norway, September 9-11 2001.
- Spender, J-C. (1996), " Making Knowledge the Basis of a Dynamic Theory of the Firm ", *Strategic Management Journal*, Vol. 17, Special issue, 1996, pp. 45-62.
- Timur, K. (1988), " The Tenacious Past: Theories of Personal and Collective Conservatism ", *Journal of Economic Behavior and Organization*, Vol. 10, n° 2, pp. 143-172.
- Tsang, E. (1999), " Internationalizing the Family Firm: A Case Study of a Chinese family Business ", *Journal of Small Business Management*, Vol. 39, n°1, pp. 88-94.
- Ward, J. (1988), " The Special Role of Planning for Family Businesses ", *Family Business Review*, Vol. 1, n°2, summer 1988.
- Ward, J. (1997), " Growing the Family Business: Special Challenges and Best Practices ", *Family Business Review*, Vol. 10, n°4, December 1997.
- Ward, J. and Aronoff C. (1996), " How a Family Shapes Business Strategy ", in Joseph H. Astrachan, John L. Ward and Craig E. Aronoff (Ed.), *Family Business Sourcebook II*, pp. 113-114.
- Watkins, D. (2000), " Internationalization of Indian small scale industry (SSI) ", Paper presented at the "Rencontres de St-Galles" 2000, Saint-Galles University, pp. 505-521.
- Welsch, J. (1996), " The Impact of Family Ownership and Involvement on the Process of Management Succession ", in Richard Beckhard (Ed.), *The Best of FBR: A Celebration*, Boston: Family Firm Institute, Boston, Mass.: Family Firm Institute, pp. 96-108.

Yeung, H. (2000), " Limits to the Growth of Family-Owned Business? The Case of Chinese Transnational Corporations from Hong Kong ", *Family Business Review*, Vol. 13, n°1, March 2000.

Yli-Renko, H., Autio, E. and Tontti, V. (2002), " Social Capital, Knowledge, and the International Growth of Technology-based New Firms ", *International Business Review* 11, pp. 279-304.

ⁱ The study of Cabrera-Suarez et al. (2002) seems to initiate a knowledge-based approach for the family firm.

ⁱⁱ The recurring problem of family firm definition will not be addressed. On this question, Cf. Astrachan, and ali. (2002) or Litz, (1995). Here we choose to adopt a general and common definition.

ⁱⁱⁱ In France, Gérard Hirigoyen distinguishes between government and governance, the first pertaining to direction and decision, the second dealing with mechanisms of control.

^{iv} For the firms which adopt one.

^v Nevertheless, the positive role of outsiders is frequently questioned and authors criticize their lack of knowledge of the firm and his environment, their low availability and weak authority.

^{vi} According to Adam-Ledunois, and Le Vigoureux, (1998), when they cooperate, the natural preference of SMEs goes for situations which see emerging a mutual dependence rather than the subservience for one of the parties (Adam-Ledunois, and Le Vigoureux, 1998).

^{vii} Cf. Granovetter, (1973).