



**HAL**  
open science

## New turbulence models preserving symmetries

Dina Razafindralandy, Aziz Hamdouni, M. Oberlack

► **To cite this version:**

Dina Razafindralandy, Aziz Hamdouni, M. Oberlack. New turbulence models preserving symmetries. 5th International Symposium on Turbulence and Shear Flow Phenomen, Aug 2007, Munich, Germany. hal-00312562

**HAL Id: hal-00312562**

**<https://hal.archives-ouvertes.fr/hal-00312562>**

Submitted on 1 Apr 2019

**HAL** is a multi-disciplinary open access archive for the deposit and dissemination of scientific research documents, whether they are published or not. The documents may come from teaching and research institutions in France or abroad, or from public or private research centers.

L'archive ouverte pluridisciplinaire **HAL**, est destinée au dépôt et à la diffusion de documents scientifiques de niveau recherche, publiés ou non, émanant des établissements d'enseignement et de recherche français ou étrangers, des laboratoires publics ou privés.

# NEW TURBULENCE MODELS PRESERVING SYMMETRIES

**Dina Razafindralandy**

Chair of Fluid Dynamics  
Department of Mechanical Engineering  
Technische Universität Darmstadt  
Hochschulstr. 1, D-64289 Darmstadt, Germany  
drzafin@fdy.tu-darmstadt.de

**Aziz Hamdouni**

LEPTAB, Pôle Sciences et Technologie  
Université de La Rochelle  
Av. Michel Crépeau, 17042 La Rochelle Cedex 1, France  
ahamdoun@univ-lr.fr

**Martin Oberlack**

Chair of Fluid Dynamics  
Department of Mechanical Engineering  
Technische Universität Darmstadt  
Hochschulstr. 1, D-64289 Darmstadt, Germany  
oberlack@fdy.tu-darmstadt.de

## ABSTRACT

Some subgrid turbulence models are analysed according to the symmetry group of the Navier–Stokes equations. Since a major part of them destroy the symmetry properties of the equations, a new class of subgrid models is proposed. These new models are expected to restore the fundamental physical properties of the equations (conservation laws, scaling laws, ...) which are contained in the symmetries. Moreover, the derived models are conform with the second law of thermodynamics. A numerical test is presented.

## INTRODUCTION

Symmetry represents a certain invariance in the evolution of nature. And it is now recognized that it plays a fundamental role in physics. Some principles which argue this are the Galilean invariance, embodied by Newton's laws of mechanics, and the relativity principles. Moreover, the Noether's theorem, which shows that a conservation law can be derived from any continuous symmetry of the action of a Lagrangian (Noether and Tavel, 1971), has a central importance in theoretical physics. The symmetry theory provides also efficient analytical methods to solve differential equations.

If symmetry is adopted as the most dominant concept in the exploration and formulation of fundamental laws in some field of physics, such as in quantum mechanics and gauge theory, its application in the study of turbulence is at its first steps. However, some works already show that the symmetry approach can lead to extremely important results in turbulence. For example, Ünal (1994) showed that the Kolmogorov cascade of energy is a manifestation of a particular scaling symmetry of the Navier–Stokes equations. This sym-

metry is a combination of transformations (6) and (7) below which leaves the dissipation rate invariant. Secondly, Razafindralandy and Hamdouni (2006) pointed out that even if the Navier–Stokes equations do not have a Lagrangian formulation, Noether's theorem can be applied to them. They used an idea proposed by Ibragimov and Kolsrud (2004) which consists in adding to the equations new (adjoint) equations such that together, they can be written in a Lagrangian form. Next, Oberlack (2001) used the symmetry theory to derive classical and new scaling laws for turbulent flows. Gandarias et al. (1998) proved also the existence of a bounded travelling wave solution for the  $k - \epsilon$  turbulence model. Finally, we mention that Grassi et al. (2000) got, from the symmetry approach, solutions of the Navier–Stokes equations which represent models of vortices. Such solutions are useful to study the instabilities present in a turbulent flow.

There exist two strategies to use symmetry. The first one is that, knowing the evolution law of a physical system, one calculates the symmetry transformations of the equations and deduces some properties or solutions. It is the way generally used in turbulence. The reverse strategy is that, observing some symmetries of a physical system, one deduces the evolution law. This way has been used for example to construct the relativity theories. In our case, the symmetry transformations of the Navier–Stokes equations are known. In this communication, we then propose to use the reverse way to derive a general form of turbulence models. Such models should be more capable to represent correctly a flow compared to symmetry-breaking models because the latter are unable to reproduce the physical properties of the flow which are contained in the symmetries (conservation laws, scaling laws, ...).

In conjunction with the symmetry approach, we use the second principle of thermodynamics for the

construction of turbulent models. Note that the conformity to this principle leads to the stability of the models (Razafindralandy et al., 2007).

This paper is structured as follow. The symmetry group of the Navier–Stokes equations are recalled in the next section. Some usual subgrid turbulence models are then analysed according to their compatibility with this group. This analysis is an extension of the work of Oberlack (1997) to a wider class of turbulence models. Next, a new class of symmetry preserving subgrid models is built. This class is then refined to the models which are conform to the second principles of thermodynamics. Lastly, a numerical test is presented.

## THE SYMMETRIES OF THE NAVIER–STOKES EQUATIONS

Consider an incompressible and isotherm newtonian fluid, with density  $\rho$  and kinematic viscosity  $\nu$ . The motion of this fluid is governed by the Navier–Stokes equations

$$\begin{cases} \frac{\partial \mathbf{u}}{\partial t} + \operatorname{div}(\mathbf{u} \otimes \mathbf{u}) + \frac{1}{\rho} \nabla p = \operatorname{div} \mathbf{T} \\ \operatorname{div} \mathbf{u} = 0 \end{cases} \quad (1)$$

where  $\mathbf{u} = (u_i)_{i=1,2,3}$  and  $p$  are respectively the velocity and pressure fields and  $t$  the time variable.  $\mathbf{T}$  is the tensor such that  $\rho \mathbf{T}$  is the viscous constraint tensor. It can be linked to the strain rate tensor  $\mathbf{S} = (\nabla \mathbf{u} + {}^T \nabla \mathbf{u})/2$  according to the relation:

$$\mathbf{T} = \frac{\partial \psi}{\partial \mathbf{S}},$$

$\psi$  being the positive and convex “potential” defined by:

$$\psi = \nu \operatorname{tr} \mathbf{S}^2.$$

A symmetry transformation of the Navier–Stokes equations is a transformation, acting on the dependant and independant variables, which remains the equations unchanged (Olver, 1986; Ibragimov, 1994). Equivalently, a symmetry transformation is a transformation which maps a solution to another solution. The set of the symmetry transformations of the Navier–Stokes equations forms a Lie group spanned by the following transformations (Danilov, 1967; Pukhnachev, 1972):

- the time translation:

$$(t, \mathbf{x}, \mathbf{u}, p) \mapsto (t + a, \mathbf{x}, \mathbf{u}, p) \quad (2)$$

where  $\mathbf{x} = (x_i)_{i=1,2,3}$  is the spatial variable and  $a$  is the parameter of the transformation,

- the pressure translation:

$$(t, \mathbf{x}, \mathbf{u}, p) \mapsto (t, \mathbf{x}, \mathbf{u}, p + \zeta(t)) \quad (3)$$

where  $\zeta$  is an arbitrary function,

- the rotation:

$$(t, \mathbf{x}, \mathbf{u}, p) \mapsto (t, \mathbf{R}\mathbf{x}, \mathbf{R}\mathbf{u}, p) \quad (4)$$

where  $\mathbf{R}$  is a rotation matrix,

- the generalized Galilean transformation:

$$(t, \mathbf{x}, \mathbf{u}, p) \mapsto (t, \mathbf{x} + \boldsymbol{\alpha}(t), \mathbf{u} + \boldsymbol{\alpha}'(t), p - \rho \mathbf{x} \cdot \boldsymbol{\alpha}''(t) - \boldsymbol{\alpha}'(t) \cdot \boldsymbol{\alpha}''(t)/2) \quad (5)$$

where  $\boldsymbol{\alpha}$  is an arbitrary vector and the symbol “ $\cdot$ ” represents the Euclidean scalar product

- and the first scale transformation:

$$(t, \mathbf{x}, \mathbf{u}, p) \mapsto (e^{2a}t, e^a \mathbf{x}, e^{-a} \mathbf{u}, e^{-2a} p). \quad (6)$$

If we consider moreover transformations which act on the viscosity in addition to  $t, \mathbf{x}, \mathbf{u}$  and  $p$ , we obtain the second scaling symmetry (Ibragimov and Ünal, 1994):

$$(t, \mathbf{x}, \mathbf{u}, p, \nu) \mapsto (t, e^a \mathbf{x}, e^a \mathbf{u}, e^{2a} p, e^{2a} \nu). \quad (7)$$

Note that the invariance of the Navier–Stokes equations under the pressure translation (3) is due to the fact that these equations determine the pressure only up to an additive temporal function. Next, when  $\boldsymbol{\alpha}$  is linear, transformation (5) gives the classical Galilean transformation. The scale symmetry (6) (respectively (7)) shows how the solution  $(\mathbf{u}, p)$  changes when the spatio-temporal scale (resp. the spatial scale and the viscosity or the Reynolds number) changes.

The Navier–Stokes equations have two last known symmetries:

- the reflection:

$$(t, \mathbf{x}, \mathbf{u}, p) \mapsto (t, \boldsymbol{\Lambda} \mathbf{x}, \boldsymbol{\Lambda} \mathbf{u}, p), \quad (8)$$

where

$$\boldsymbol{\Lambda} = \begin{pmatrix} \iota_1 & 0 & 0 \\ 0 & \iota_2 & 0 \\ 0 & 0 & \iota_3 \end{pmatrix} \quad \text{with } \iota_i = \pm 1, \quad i = 1, 2, 3$$

- and the material indifference in the limit of a 2D flow (Cantwell, 1978):

$$(t, \mathbf{x}, \mathbf{u}, p) \mapsto (t, \widehat{\mathbf{x}}, \widehat{\mathbf{u}}, \widehat{p}), \quad (9)$$

with

$$\widehat{\mathbf{x}} = \mathbf{R}(t) \mathbf{x}, \quad \widehat{\mathbf{u}} = \mathbf{R}(t) \mathbf{u} + \dot{\mathbf{R}}(t) \mathbf{x}, \quad (10)$$

and

$$\widehat{p} = p - 3\omega\varphi + \frac{1}{2}\omega^2 \|\mathbf{x}\|^2 \quad (11)$$

where  $\mathbf{R}(t)$  is a 2D rotation matrix with angle  $\omega t$ ,  $\omega$  an arbitrary real constant,  $\varphi$  the usual 2D stream function defined by:

$$\mathbf{u} = \operatorname{curl}(\varphi \mathbf{e}_3),$$

$\mathbf{e}_3$  the unit vector perpendicular to the plane of the flow and  $\|\cdot\|$  indicates the Euclidean norm.

Symmetries have an important role, as seen in the introduction. To some extent, they contain the physics of the equations. So, turbulent models have to respect them. In the next section, we analyze some standard

LES models according to their compatibility with the symmetries.

## MODEL ANALYSIS

LES consists in reducing the computation time by dropping the small scales of the unknown fields  $\mathbf{u}$  and  $p$ . This is done by using a filter, symbolized herein by the symbol bar ( $\bar{\cdot}$ ) and having a width  $\bar{\delta}$ .  $(\mathbf{u}, p)$  is then approximated by the filtered couple  $(\bar{\mathbf{u}}, \bar{p})$ . To obtain  $(\bar{\mathbf{u}}, \bar{p})$ , one applies the filter to (1). It gives:

$$\begin{cases} \frac{\partial \bar{\mathbf{u}}}{\partial t} + \operatorname{div}(\bar{\mathbf{u}} \otimes \bar{\mathbf{u}}) + \frac{1}{\rho} \nabla \bar{p} = \operatorname{div}(\bar{\mathbf{T}} + \mathbf{T}_s), \\ \operatorname{div} \bar{\mathbf{u}} = 0. \end{cases} \quad (12)$$

In these equations,  $\mathbf{T}_s$  is the subgrid constraint tensor, defined by

$$\mathbf{T}_s = \bar{\mathbf{u}} \otimes \bar{\mathbf{u}} - \widetilde{\bar{\mathbf{u}} \otimes \bar{\mathbf{u}}}, \quad (13)$$

which represents the effect of the (dropped) small scales on the bigger ones and which must be modeled in order to close the equations. Currently, a large number of models exists. Some of the most common ones are reminded below (see Sagaut (2004); John (2004)):

- the Smagorinsky model:

$$\mathbf{T}_s^d = (C\bar{\delta})^2 |\bar{\mathbf{S}}| \bar{\mathbf{S}} \quad (14)$$

where the superscript  $d$  represents the deviatoric part of a tensor and  $|\bar{\mathbf{S}}| = \sqrt{2} \|\bar{\mathbf{S}}\|$ ,

- the dynamic model:

$$\mathbf{T}_s^d = C_d \bar{\delta}^2 |\bar{\mathbf{S}}| \bar{\mathbf{S}} \quad (15)$$

where  $C_d = [\operatorname{tr}(\mathbf{LM})]/[\operatorname{tr} \mathbf{M}^2]$ ,  $\mathbf{L} = \widetilde{\bar{\mathbf{u}} \otimes \bar{\mathbf{u}}} - \widetilde{\bar{\mathbf{u}} \otimes \bar{\mathbf{u}}}$ , and  $\mathbf{M} = \bar{\delta}^2 |\bar{\mathbf{S}}| \bar{\mathbf{S}} - \widetilde{\bar{\delta}^2 |\bar{\mathbf{S}}| \bar{\mathbf{S}}}$ ,

- the structure function model:

$$\mathbf{T}_s^d = C_{SF} \bar{\delta} \sqrt{\overline{F_2(\bar{\delta})}} \bar{\mathbf{S}} \quad (16)$$

where

$$\overline{F_2(\bar{\delta})} = \int \int_{\|\mathbf{z}\|=\bar{\delta}} \|\bar{\mathbf{u}}(\mathbf{x}) - \bar{\mathbf{u}}(\mathbf{x} + \mathbf{z})\|^2 \, d\mathbf{z} \, dx,$$

- the gradient model:

$$\mathbf{T}_s = -\frac{\bar{\delta}^2}{12} \nabla \bar{\mathbf{u}} \, {}^T \nabla \bar{\mathbf{u}}, \quad (17)$$

- the Taylor model:

$$\mathbf{T}_s = -\frac{\bar{\delta}^2}{12} \nabla \bar{\mathbf{u}} \, {}^T \nabla \bar{\mathbf{u}} + C\bar{\delta}^2 |\bar{\mathbf{S}}| \bar{\mathbf{S}}, \quad (18)$$

- the rational model:

$$\mathbf{T}_s = -\frac{\bar{\delta}^2}{12} G * [\nabla \bar{\mathbf{u}} \, {}^T \nabla \bar{\mathbf{u}}] + C\bar{\delta}^2 |\bar{\mathbf{S}}| \bar{\mathbf{S}} \quad (19)$$

where  $G$  is the kernel of the Gaussian filter,

- the similarity model:

$$\mathbf{T}_s = \widetilde{\bar{\mathbf{u}} \otimes \bar{\mathbf{u}}} - \widetilde{\bar{\mathbf{u}} \otimes \bar{\mathbf{u}}}, \quad (20)$$

- the Lund–Novikov model:

$$\begin{aligned} \mathbf{T}_s^d &= C_1 \bar{\delta}^2 |\bar{\mathbf{S}}| \bar{\mathbf{S}} + C_2 \bar{\delta}^2 (\bar{\mathbf{S}}^2)^d + C_3 \bar{\delta}^2 (\bar{\mathbf{W}}^2)^d + \\ &C_4 \bar{\delta}^2 (\bar{\mathbf{S}} \bar{\mathbf{W}} - \bar{\mathbf{W}} \bar{\mathbf{S}}) + C_5 \bar{\delta}^2 \frac{1}{|\bar{\mathbf{S}}|} (\bar{\mathbf{S}}^2 \bar{\mathbf{W}} - \bar{\mathbf{S}} \bar{\mathbf{W}}^2) \end{aligned} \quad (21)$$

- and the Kosovic model:

$$\mathbf{T}_s^d = (C\bar{\delta})^2 \left[ 2|\bar{\mathbf{S}}| \bar{\mathbf{S}} + C_1 (\bar{\mathbf{S}}^2)^d + C_2 (\bar{\mathbf{S}} \bar{\mathbf{W}} - \bar{\mathbf{W}} \bar{\mathbf{S}}) \right]. \quad (22)$$

Here, the symbol tilde ( $\widetilde{\cdot}$ ) represents a test filtering, with a filter width  $\widetilde{\delta}$ ,  $\mathbf{W}$  is the vorticity tensor and  $C$  and  $C_i$  are real constants.

The introduction of turbulence models may destroy the symmetry properties of the equations. Indeed, equations (12) may not have the same invariance properties as the Navier–Stokes equations (1) under the transformations (2)–(9). As a consequence, the solution given by a symmetry-breaking turbulence model may not restore the fundamental physical information contained in the actual solution (conservation laws, spectral properties, ...).

In this section, we investigate the cited turbulence models under their compatibility with the symmetries of the Navier–Stokes equations. We will say that a model is *invariant* under a symmetry transformation of (1) if the same transformation, applied to  $(t, \mathbf{x}, \bar{\mathbf{u}}, \bar{p}, \nu)$ , is also a symmetry of the filtered equations (12) when this model is used.

Since the importance of the invariance of a turbulence model under the time translation (2), the rotation (4), the classical Galilean transformation and the reflection (8) has been understood for a long time, all turbulence models are invariant under these transformations. This invariance extends to the generalized Galilean transformation (5). Moreover, the above turbulence models are autonomous in pressure. Consequently, they are invariant under the pressure translation (3).

The two scale transformations (6) and (7) can be combined into the following two-parameter scaling transformation:

$$(t, \mathbf{x}, \mathbf{u}, p, \nu) \mapsto (e^{2a} t, e^{b+a} \mathbf{x}, e^{b-a} \mathbf{u}, e^{2b-2a} p, e^{2b} \nu). \quad (23)$$

The first scale transformation (6) corresponds to  $b = 0$  and the second, (7), to  $a = 0$ . Equations (12) are invariant under (23) if and only if the image  $\widehat{\mathbf{T}}_s$  of  $\mathbf{T}_s$  is

$$\widehat{\mathbf{T}}_s = e^{2b-2a} \mathbf{T}_s. \quad (24)$$

Relation (24) is then the condition for a turbulence model to be invariant under the scale transformations (6) and (7).

If we take the Smagorinsky model (14), we have:

$$\widehat{\mathbf{T}}_s = e^{-4a} \mathbf{T}_s. \quad (25)$$

Since condition (24) is violated as well when  $a = 0$  as when  $b = 0$ , we conclude that this model is invariant neither under the first nor under the second scale

transformation. Note that the filter width  $\bar{\delta}$  does not vary since it is an external length scale and has no functional dependence on the variables of the flow.

Using similar arguments, it is straight forward to prove that, among the presented turbulence models, only the dynamic and the scale similarity models verify (24) and are invariant under the scale transformations.

The last symmetry of the Navier–Stokes equations to be considered is the material indifference (9) in the limit of 2D flow. A turbulence model is invariant under this symmetry if the following condition is verified (the explicit dependence on time of  $\mathbf{R}$  is not written):

$$\widehat{\mathbf{T}}_s = \mathbf{R}\mathbf{T}_s^T \mathbf{R}. \quad (26)$$

The objectivity of  $\bar{\mathbf{S}}$  directly leads to the invariance of the Smagorinsky model.

Under a good condition on the test filter (see Razafindralandy et al. (2007)), the similarity model and the dynamic model verify condition (26) and are invariant. On the other hand, the non-objectivity of the structure function leads to the non-invariance of the structure function model (16). Next, because of the non-objectivity of the gradient of the velocity, contrarily to the strain rate tensor, the gradient and the Taylor models are also non-invariant under the material indifference. In the same way, the non-objectivity of the vorticity tensor  $\mathbf{W}$  leads to the non-invariance of the Kosovic and the Lund–Novikov models.

In conclusion, only the dynamic and the scale similarity models are invariant under the scale transformations. In addition to the Smagorinsky model, these two models are also the only models, among the ones presented, which are material indifferent.

The non-invariance of a turbulence model under the symmetries of the Navier–Stokes equations has a grave consequence. Indeed, for instance, if we perform a zoom operation, in which the spatio-temporal scale is multiplied by  $(e^{2a}, e^a)$ , the actual solution  $(\mathbf{u}, p)$  is affected by a factor  $(e^{-a}, e^{-2a})$ , according to (6), but the the solution  $(\bar{\mathbf{u}}, \bar{p})$  given by a non-invariant model does not follow the same rule. Moreover, as we said, symmetry contains fundamental information on the flow, which may be lost when we use a non-invariant model.

In the next section, we propose a class of new subgrid turbulence models whose derivation is based on the respect of the symmetries of the Navier–Stokes equations. This class is then refined to models which, contrarily to some popular models like the dynamic model which may induce negative dissipation, are conform to the second law of thermodynamics.

## SYMMETRY AND THERMODYNAMICALLY CONSISTENT MODELS

In order to have models which are invariant under the translations (2), (3), (5) and under the rotations (4) and (9), the subgrid stress tensor  $\mathbf{T}_s$  is taken to be a function of the filtered strain rate tensor  $\bar{\mathbf{S}}$ , and of the objective scalar quantities  $q$ , the subgrid-scale energy, and  $\varepsilon$ , the dissipation rate. The invariance theory leads to the following form of the deviatoric

part of the model:

$$\mathbf{T}_s^d = A_0(\chi, \zeta, q, \varepsilon) \bar{\mathbf{S}} + B_0(\chi, \zeta, q, \varepsilon) \text{Adj}^d \bar{\mathbf{S}} \quad (27)$$

where  $\chi = \text{tr} \bar{\mathbf{S}}^2$  and  $\zeta = \det \bar{\mathbf{S}}$  are the invariants of  $\bar{\mathbf{S}}$ .  $A_0$  and  $B_0$  are arbitrary scalar functions and the operator  $\text{Adj}$  is defined by

$$(\text{Adj} \bar{\mathbf{S}}) \bar{\mathbf{S}} = (\det \bar{\mathbf{S}}) I_d, \quad (28)$$

$I_d$  being the identity operator. Finally, the invariance under the scale transformations (6) and (7) lead to:

$$\mathbf{T}_s^d = \frac{q^2}{\varepsilon} \left( A(v) \bar{\mathbf{S}} + \frac{1}{\sqrt{\chi}} B(v) \text{Adj}^d \bar{\mathbf{S}} \right). \quad (29)$$

where  $v = \frac{\zeta}{\chi^{3/2}}$ .  $A$  and  $B$  are arbitrary scalar functions.

Relation (29) defines then a class of symmetry preserving subgrid turbulence models. Let us now consider the second law of thermodynamics.

On molecular scale, the viscous constraint  $\mathbf{T}$  can be written in a “potential” form:

$$\mathbf{T} = \frac{\partial \psi}{\partial \mathbf{S}} \quad (30)$$

where  $\psi = \nu \text{tr} \mathbf{S}^2$ . This potential form is important because the convexity and positivity of  $\psi$  ensures that the molecular dissipation is positive. Since the subgrid tensor  $\mathbf{T}_s$  can be considered as a constraint, we assume that it can also be written in a potential form:

$$\mathbf{T}_s = \frac{\partial \psi_s}{\partial \bar{\mathbf{S}}} \quad (31)$$

where  $\psi_s$  is a function of  $\bar{\mathbf{S}}$ . This hypothesis holds if and only if:

$$\frac{\partial}{\partial \zeta} \left( \frac{1}{2} A(v) \right) = \frac{\partial}{\partial \chi} \left( \frac{1}{\sqrt{\chi}} B(v) \right). \quad (32)$$

This condition requires the existence of a dimensionless function  $g$  such that

$$\mathbf{T}_s^d = \frac{q^2}{\varepsilon} \left[ \left( 2g(v) - 3v\dot{g}(v) \right) \bar{\mathbf{S}} + \frac{1}{\sqrt{\chi}} \dot{g}(v) \text{Adj}^d \bar{\mathbf{S}} \right]. \quad (33)$$

If  $\Phi_T$  is the total dissipation, we have:

$$\Phi_T = \rho \text{tr}[(\bar{\mathbf{T}} + \mathbf{T}_s) \bar{\mathbf{S}}]. \quad (34)$$

Finally,  $\Phi_T$  is positive if and only  $g$  verifies the following condition:

$$\nu + \frac{q^2}{\varepsilon} g(v) \geq 0. \quad (35)$$

In summary, models of form (33) and verifying (35) are invariant under the symmetry group of NS and are conform with the second law of thermodynamics.

## NUMERICAL TEST

Numerical tests on model (33) are still ongoing. In what follows, a numerical test on another model built in Razafindralandy and Hamdouni (2005) is presented.

Like the present one, this model is invariant under the symmetry group of NS equations, but it has an explicit dependence on the viscosity instead of a dependence on  $q$  and  $\varepsilon$ . However, as will be seen, it already gives encouraging results.

An air flow inside a ventilated room (Nielsen cavity, figure 1) which interests us for applications in building domain is considered. The Reynolds number, computed from the height of the intake opening is about 5000. The function  $g$  is chosen linear. The numerical scheme, based on a finite difference discretisation method, is described in Chen et al. (2001). A  $72 \times 52 \times 26$  grid is used. The time step is  $7.10^{-3}$ s and the calculation is led to 1200s.

Figure 2 reports the horizontal velocity profiles, along the vertical line defined by ( $x_1 = 2L/3$ ,  $x_3 = W/2$ ), given by the Smagorinsky model, the dynamic model and our model (called here “invariant model”). It can be observed that the invariant model gives a result in good agreement with experiments, except near the floor, but in all cases better than those provided by the two other models. Near the upper wall, it predicts particularly well the velocity profile. Note that no wall function was used.

## CONCLUSION

As in (Oberlack, 1997), we conclude that many existing turbulence models are not compatible with the symmetries of the Navier–Stokes equations. The same conclusion has been drawn in the case of a non-isothermal fluid in (Razafindralandy and Hamdouni, 2007). Next, we showed that the symmetry approach, combined to the second law of thermodynamics, can be used to derive turbulence models. Finally, the preliminary test showed that these models, since they are consistent with the physics of the equations, may lead to numerically performant results.

## REFERENCES

- Cantwell, B. (1978). Similarity transformations for the two-dimensional, unsteady, stream-function equation. *Journal of Fluid Mechanics*, 85:257–271.
- Chen, Q., Jiang, Y., Béghein, C., and Su, M. (2001). Particulate dispersion and transportation in buildings with large eddy simulation. Technical report, Massachusetts Institute of Technology.
- Danilov, Y. (1967). Group properties of the maxwell and navier–stokes equations. *Preprint, Khurchatov Inst. Nucl. Energy, Acad. Sci. USSR*.
- Gandarias, M., Medina, E., and Bruzón, M. (1998). An approach to the  $b - \epsilon$  model for turbulence through symmetry reductions. *Europhysics Letters*, 44(6):679–685.
- Grassi, V., Leo, R., Soliani, G., and Tempesta, P. (2000). Vorticies and invariant surfaces generated by symmetries for the 3D Navier-Stokes equation. *Physica A*, 286:79–108.

Ibragimov, N. (1994). *CRC handbook of Lie group analysis of differential equations. Vol 1: Symmetries, exact solutions and conservation laws*. CRC Press.

Ibragimov, N. and Kolsrud, T. (2004). Lagrangian approach to evolution equations : symmetries and conservation laws. *Nonlinear Dynamics*, 36(1):29–40.

Ibragimov, N. and Ünal, G. (1994). Equivalence transformations of Navier-Stokes equations. *Bulletin of the Technical University of Istanbul*, 47(1-2):203.

John, V. (2004). *Large Eddy Simulation of Turbulent Incompressible Flows. Analytical and Numerical Results for a Class of LES Models*, volume 34 of *Lecture Notes in Computational Science and Engineering*. Springer-Verlag.

Nöther, E. and Tavel, A. (1971). Invariant variation problems. *Transport Theory and Statistical Physics*, 1(3):183–207. English traduction of the Nöther’s original paper.

Oberlack, M. (1997). Invariant modeling in large-eddy simulation of turbulence. In *Annual Research Briefs*. Stanford University.

Oberlack, M. (2001). A unified approach for symmetries in plane parallel turbulent shear flows. *Journal of Fluid Mechanics*, 427:299–328.

Olver, P. (1986). *Applications of Lie groups to differential equations*. Graduate texts in mathematics. Springer-Verlag.

Pukhnachev, V. (1972). Invariant solution of Navier-Stokes equations describing motions with free boundary. *Doklady Akademii Nauk SSSR*, pages 202–302.

Razafindralandy, D. and Hamdouni, A. (2005). Subgrid models preserving the symmetry group of Navier-Stokes equations. *Comptes Rendus Mécanique*, 333:481–486.

Razafindralandy, D. and Hamdouni, A. (2006). Consequences of symmetries on the analysis and construction of turbulence models. *Symmetry, Integrability and Geometry: Methods and Applications*, 2:Paper 052.

Razafindralandy, D. and Hamdouni, A. (2007). Invariant subgrid modelling in large-eddy simulation of heat convection turbulence. *Theoretical and Computational Fluid Dynamics*.

Razafindralandy, D., Hamdouni, A., and Oberlack, M. (2007). Analysis and development of subgrid turbulence models preserving the symmetry properties of the Navier–Stokes equations. *European Journal of Mechanics/B*, 26.

Sagaut, P. (2004). *Large eddy simulation for incompressible flows. An introduction*. Scientific Computation. Springer.

Ünal, G. (1994). Application of equivalence transformations to inertial subrange of turbulence. *Lie Group and Their Applications*, 1(1):232–240.

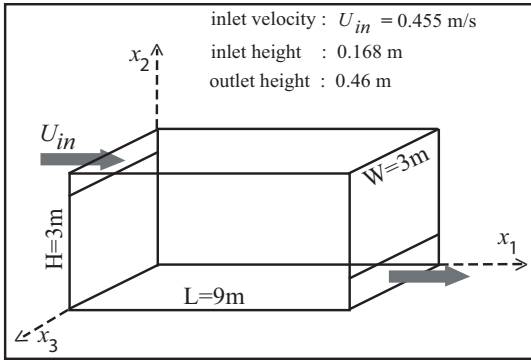

Figure 1: Geometry of the room

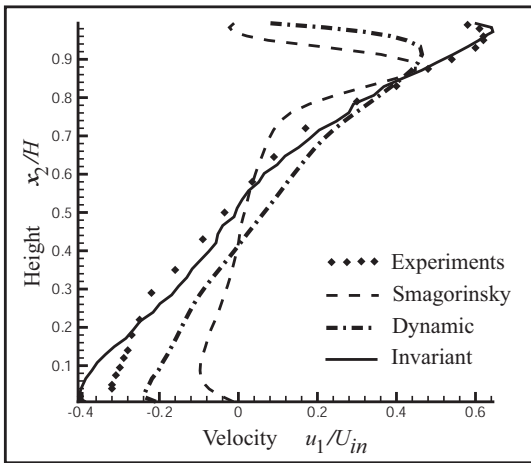

Figure 2: Mean velocity profiles