

# A Real-Time Closed-Loop Setup for Hybrid Neural Networks

G. Bontorin, S. Renaud, A. Garenne, L. Alvado, G. Le Masson, J. Tomas

► **To cite this version:**

G. Bontorin, S. Renaud, A. Garenne, L. Alvado, G. Le Masson, et al.. A Real-Time Closed-Loop Setup for Hybrid Neural Networks. Proc. of the 29th Annual Int. Conference of the IEEE EMBS, Aug 2007, Lyon, France. pp.3004-3007. hal-00181426

**HAL Id: hal-00181426**

**<https://hal.archives-ouvertes.fr/hal-00181426>**

Submitted on 24 Oct 2007

**HAL** is a multi-disciplinary open access archive for the deposit and dissemination of scientific research documents, whether they are published or not. The documents may come from teaching and research institutions in France or abroad, or from public or private research centers.

L'archive ouverte pluridisciplinaire **HAL**, est destinée au dépôt et à la diffusion de documents scientifiques de niveau recherche, publiés ou non, émanant des établissements d'enseignement et de recherche français ou étrangers, des laboratoires publics ou privés.

# A Real-Time Closed-Loop Setup for Hybrid Neural Networks

G. Bontorin, *Student Member, IEEE*, S. Renaud, A. Garenne, L. Alvado, G. Le Masson, J. Tomas

**Abstract**— Hybrid living-artificial neural networks are an efficient and adaptable experimental support to explore the dynamics and the adaptation process of biological neural systems. We present in this paper an innovative platform performing a real-time closed-loop between a cultured neural network and an artificial processing unit like a robotic interface. The system gathers bioware, hardware, and software components and ensures the closed-loop data processing in less than 50  $\mu$ s. We detail here the system components and compare its performances to a recent commercial platform.

## I. INTRODUCTION

LEARNING and adaptation are essential in the nervous systems, although quite misunderstood. Adaptation phenomena are widely investigated, and their basic mechanisms have been identified, like Long Term Potentiation (LTP) or Spike Timing Dependent Plasticity (STDP) [1]. However, the exploitation of these models in large and complex networks are not mature enough. By "large networks", we mean biological structures in which plasticity mechanisms at the cellular level during the learning process result in effective learning when translated at the behavioral level.

Among the experimental techniques that have been developed to investigate the dynamics of neural networks, we have focused on the hybrid neural networks approach. Such a network comprises a biological network connected to an artificial neural network or any artificial unit that communicate in real-time with its biological counterpart: the whole system forms a closed-loop system.

Such closed-loop systems can be separated in two categories, depending on the connection interface between living and artificial neurons: (i) intracellular electrodes [2] or (ii) extracellular [3] electrodes. Intracellular access provides the neuron membrane voltage with a good signal to noise ratio (SNR), but connections are restricted to a small number and a limited duration (few hours).

Extracellular electrodes, implemented on Multi Electrodes Arrays (MEAs) devices, are appropriate to study complex networks. They allow multisite acquisition and stimulation, without perforating the cellular membrane. However, the neural signal, measured through capacitive coupling on the

electrodes, is weaker ( $\sim 10$ - $100 \mu$ V peak-to-peak), and the noise level ( $\sim 1$  mV at low frequencies) is higher. Such an interface requires the use of carefully designed filters and amplifiers stages to process the neural signal.

We describe in this paper a setup designed to run experiments on hybrid neural networks. The "HyNNet" platform includes a real-time closed-loop, in which the activity of a neuron culture plated on a MEA is analyzed and controlled by an artificial apparatus (hardware and software material, see Fig. 1). We will detail each one of the constituting blocks of the closed-loop, present their performances, and conclude on the whole system.

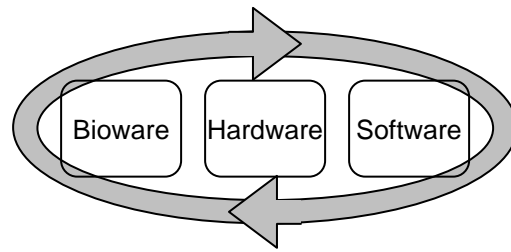

Fig. 1. Elements of the *HyNNet* closed-loop.

## II. THE CLOSED-LOOP SETUP

"Closed-loop" means that the two parts of the hybrid network communicate in bidirectional mode with each other, and that each one receives controlling inputs from the other. The artificial parts of the system (hardware + software) run the "bioware" data acquisition, its processing, and the generation of feedback stimulation patterns. We detail in this section the three HyNNet's components: bioware, hardware, and software (Fig. 2).

### A. Bioware

The first component of the system supports the biological material, and provides the access for the signal acquisition and the electrode stimulation. It includes:

a) the cell cultures (dissociated cultures of rat embryonic cortical cells [4]), placed on a MEA circuit.

b) the MEA: a 60-electrode (planar electrodes with a  $30 \mu$ m diameter) device from MultiChannelsSystems (MCS, [5]). The MEA provides a parallel access for the acquisition and the stimulation of all the electrode sites.

c) a breakout box (BBMEA from MCS) that separates the acquisition (MEA outputs) and stimulation (MEA inputs) channels for the 60 electrodes. A MEA1060 amplifier with a fixed gain of 1200 amplifies the MEA outputs [5-7].

This work was supported the European Union: "Neurobit" IST-2001-33564 and "Facets" FP6-2004-IST-FETPI 15879.

G. Bontorin, J. Tomas and S. Renaud are with IMS Laboratory – ENSEIRB University of Bordeaux I, 351 cours de la Lib ration, F-33405 Talence, France (corresponding: G. Bontorin; e-mail: guilherme.bontorin@ims-bordeaux.fr ). L. Alvado was with IMS.

A. Garenne and G. Le Masson are with INSERM - E358, University of Bordeaux 2, 146 rue L o Saignat, F-33076 Bordeaux, France.

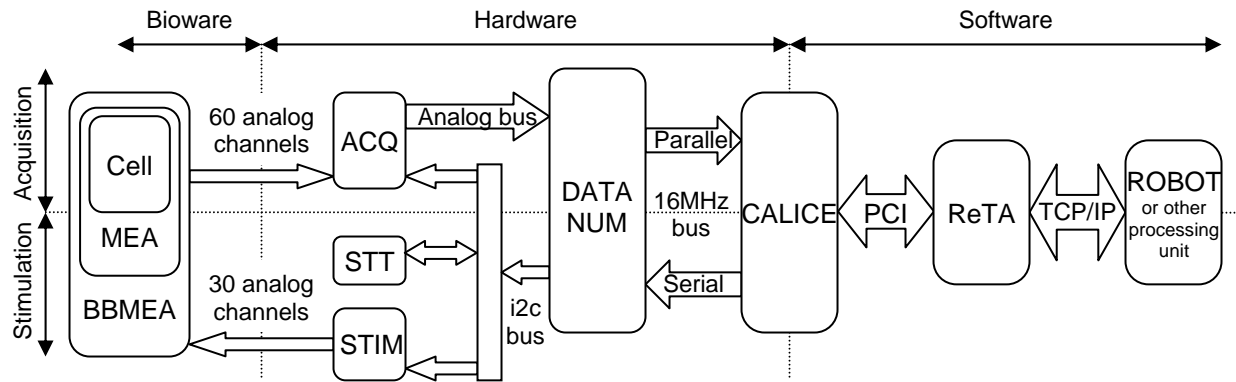

Fig. 2. Details of the HyNNNet's components and interconnections

The 60-electrode signals are finally available as analog outputs of the bioware stage. In parallel, 30-analog input channels are available for stimulation. The distribution of the stimulation channels among the 60 electrodes is configured by the user, using on-board switches. The number of stimulation channels is intentionally limited, as single stimulations are proven to have an effect on a population of neurons distributed over more than one electrode.

### B. Hardware

The second stage of the system, which is implemented on hardware, represents the bridge between the bioware and the software. The different hardware elements were specifically designed for the HyNNNet system, with the objective of providing to the user an entirely tunable system. Hardware elements are a series of boards plugged in a modular and autonomous rack that conveys buses of shared data. All boards are configurable. The parameters are: the number of channels, the gain of individual signals for acquisition; the individual shapes, patterns, and triggers of stimulation signals. The hardware constituting elements are listed here:

1) *Acquisition (ACQ) Boards*: they filter (high-pass filter with a 0.1 Hz cut-off frequency), isolate optically, and amplify the analog signals output by the bioware. They drive them on the racks' analog bus. Each ACQ board manages 4 channels with an individually controlled gain tunable between 1 and 127,000. The gain's control signal uses an i2c protocol (Inter-Integrated Circuit, [8]). For a complete 60-channel recording system, 15 ACQ boards are necessary.

2) *Stimulation (STIM) Boards*: they generate analog stimulation signals applied to the MEA electrodes. Each board controls individually 4 stimulation channels. For a complete 30-channel stimulation system, 8 boards are necessary. Stimulation patterns are configurable voltage signals, with a bipolar and biphasic pulse (see Fig. 3), starting by the positive phase. It is considered as an efficient and safe protocol [9], among the classically used ones: unipolar or bipolar, rectangular, current or voltage stimulations [10]. The parameters of each pulse are configured using the i2c local bus. The positive (TV+) and negative (TV-) pulse's widths are between 50  $\mu$ s and 3.27 s, with a 50  $\mu$ s step. The positive (V+) and negative (V-) pulse's amplitudes are between 0

and 10 V, with a 4 mV step.

3) *Stimulation Trigger (STT) Boards*: they are in charge of the stimulation patterns' trigger. STT boards provide individual sequences of trigger signals; each trigger activates the generation of a biphasic stimulation pulse. The sequences are controlled by the i2c local bus. The resulting stimulation patterns can be configured by: the number of pulses in a group; number of groups in a pattern; periods of pulses and groups (Fig. 3). Each STT board triggers 2 STIM boards, so 8 stimulation channels. The 30-channel stimulation setup necessitates 4 STT boards.

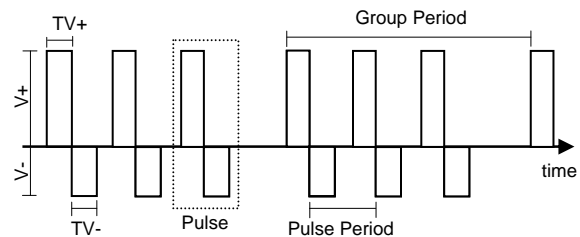

Fig. 3. A stimulation pattern with its parameters.

4) *Rack's Control Board (DATANUM)*: it controls a set of rack's channels. More precisely, it is in charge of:

(a) the digitalization of the biological signals. The board is equipped with a Xilinx® FPGA (configurable digital circuit) that controls 2 Analog-to-Digital Converters (ADC). Each ADC converts 8 channels with a resolution of 12 bits and sampling frequency of 40 kHz. This sampling rate is specified to ensure a high quality reconstruction of the neurons dynamics for offline processing. Furthermore, as the A/D conversion is implemented within the rack, no analog signal is conveyed inside the digital environment of the computer, limiting the noise.

(b) the data transfer between the rack boards and the computer PCI (Peripheral Component Interconnect) board. The acquisition data is transferred in parallel mode, as it corresponds to a great data flow; stimulation data, much more sparse, is transferred serially. Both are sampled at 16MHz.

(c) the control of the i2c bus, that manages the data, control and clock signals for the ACQ, STIM and STT boards.

Each DATANUM board controls 16 acquisition channels and 8 stimulation channels. For the 60-acquisition and 30-stimulation channel HyNNNet system, 4 boards are necessary.

5) *PCI Interface board (CALICE)*: The communication between the DATANUM boards and the PCI bus of the computer is controlled by a custom PCI interface board (CALICE).

This board is plugged into the computer and connected to the 4 DATANUM boards using DVI (Digital Visual Interface) ports. The functions of the CALICE board are: (a) to acquire the sampled data of the 60 channels (40 kHz, 12 bits); (b) to program the ACQ, the STIM, and the STT boards through DATANUM boards, (c) to ensure real-time processing in the closed-loop. In this topic, other computer's tasks can occupy the PCI bus for long time, enough to compromise real-time. So, 1 MiB ( $2^{20}$  Bytes) of RAM memory is used to buffer acquisition samples, to avoid data losing, and to indicate other tasks' damage to data delay. Globally, the data transfer rate is imposed by the acquisition of data from 60 channels: with a 12 bit, 40 kHz sampling, this acquisition necessitates approximately 5 MiB/s, quite under the 33 MiB/s of the PCI transfer protocol. The CALICE driver module is written in C++ and compatible with Windows XP™.

### C. Software

The last part of the HyNNet system is the software running the Real-Time Application (ReTA). Its functions are to:

1) *Configure the experiment*: a user-friendly interface allows the control of all the experiment parameters on the boards described in section II-B.

2) *Monitor the acquisitions*: the 60-channel raw data are monitored in real-time, on 1-second long windows (Fig. 4).

3) *Detect events*: spikes and bursts are detected and visualized online. Spikes are recognized from the raw signal and from the stimulation artifacts using a threshold technique. Each channel threshold can be set as an absolute voltage value or as a function of the signal's standard deviation. Bursts are defined as a series of spikes with a high instantaneous frequency.

4) *Process online statistics*: the stimuli, spikes, and bursts time stamps can be analyzed online. The software computes: the instantaneous firing rate (IFR), the inter-burst interval histogram (IBIH), the inter-spike interval histogram (ISIH) and the post-stimulus-time histogram (PSTH).

5) *Store the acquired data*: raw data, as well as the timing of spikes and bursts and the associated statistics, are stored on external files for any offline analysis [11].

6) *Close the loop*: conditions on the timing and patterns of events (spikes, bursts) can be combined to trigger the stimulation patterns. For example, the user can specify that a stimulation pattern is launched on one electrode if the instantaneous spike frequency is higher than 50Hz. The conditional rules are coded in C; in the next version of the system, they will be described using a graphical user interface.

7) *Close the loop by including a robot*: an alternative to the previous configuration (direct control of the stimulation patterns by the acquired signal) is to include a sensory-motor system in the loop. The neuron culture activity controls the displacement of a real or virtual robot in a predefined or flexi-

ble environment. The robot sensors encode for example its distance to obstacles and translate this sensory information in stimulation patterns for the cultures. In that case, the system tries to "teach" the culture an avoiding-obstacle task. These functions are currently coded in C, and the system has been tested using a Kephera™ robot model (VKephera) written in VPython®. It communicates with the ReTA core functions using a TCP/IP protocol. Benchmark experiments exploiting and validating the software features are shown in [4].

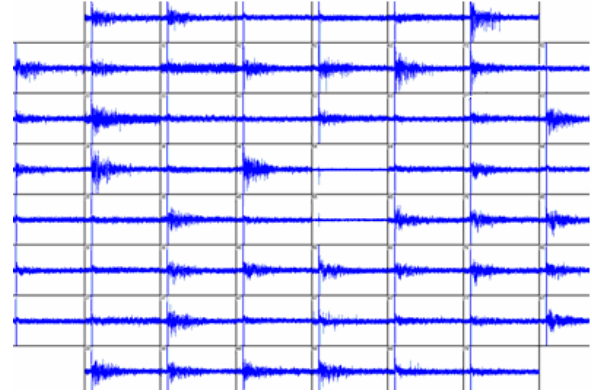

Fig. 4. Real-time display of the raw signal from the 60 acquisition channels. The location of each window corresponds to the position of its associated electrode on the MEA.

### D. Performances

We compared the specifications and performances of the HyNNet hardware elements with a recent commercial apparatus from MCS [5-7]. Results are presented in Table I. The HyNNet hardware is globally competitive with the MCS system; individual boards process less channels, but the modular architecture and the boards configurability allows the user to customize the system for its experiments.

The real benefit of the HyNNet system lies in the real-time features of the whole system (including the software).

## III. REAL-TIME IN HYNNET

"Real-time" in the HyNNet system is a strict constraint: it implies that within the time step between 2 acquisitions, all the online processing on the data available has been executed (and has generated the consequent stimulation). The "closed-loop period" is the time taken by the system between the acquisition and the related feedback stimulation. This period should not bypass the maximal sampling period, and so, imposes the minimal sampling frequency. In extracellular measurements, as is the case of MEA ones, the typical bandwidth is about 3 kHz [12], which implies a minimum sampling rate of 6 kHz. We chose to run the HyNNet system with a 10 kHz sampling rate, to ensure a correct reconstruction of biological signals.

The propagation times across the modules of HyNNet are given in Fig. 5. A 10 kHz sampling frequency corresponds to a 100  $\mu$ s period available for the loop. By summing the digital modules delays (as the analog ones are negligible), we obtain a closed-loop period of 46  $\mu$ s. So, more than 50  $\mu$ s are then available for the software at each time step, to be used by the robot or by any processing unit.

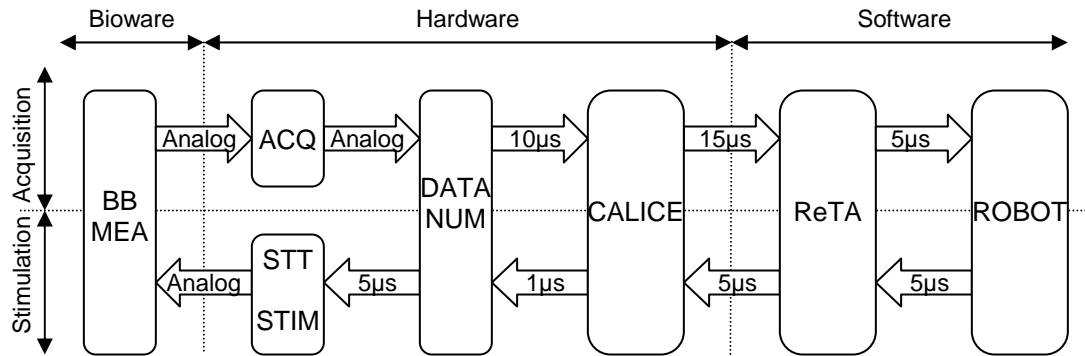

Fig. 5. Data propagation delays of the HyNNet closed-loop – The minimum closed-loop period is 46  $\mu$ s.

#### IV. CONCLUSION

A real-time closed-loop system for studying the dynamics of neural networks has been presented. It realizes a bidirectional communication between a cell culture and an artificial system. The transmission delay in the closed-loop is low enough to allow a good sampling rate and to leave time for processing the reaction stimuli, while ensuring real-time. The multielectrode interface gives the possibility to address complex neural networks. The noise issue is partly resolved by an optimized analog processing of the acquisition signals. Finally, the HyNNet system is designed to cover a wide range of experiments, as the user can set parameters on all the processing stages of the system. We are currently running experiments to address specific neuroscience questions that exploit at best the system features.

Two additional developments are in progress: (a) Due to the small closed-loop period, the system is able to handle the processing of complex learning algorithms in real-time. A complete software interface is being developed to easily design experimental protocols that will address the widely discussed issue of the existence of plasticity in cultured neural networks [13]; (b) To allow the system to support novel higher density MEAs, we are in the process of integrating the hardware stage (acquisition [14] + stimulation) on a single silicon die [15].

#### REFERENCES

- [1] W. Gerstner, and W. Kistler, *Spiking Neuron Models: Single Neurons, Populations, Plasticity*. United Kingdom, Cambridge University Press, 2002.
- [2] G. Le Masson, S. Renaud, D. Debay, and T. Bal, "Feedback inhibition controls spike transfer in hybrid thalamic circuits", *Nature*, vol. 417, June 2002, pp.854-858.
- [3] S.M. Potter, D.A. Wagenaar, and T.B. DeMarse, "Closing the loop: stimulation feedback systems for embodied MEA cultures", in *Advances in Network Electrophysiology Using Multi-Electrode Arrays* M. Taketani and M. Baudry, 1<sup>st</sup> ed. Springer, NY, 2006, pp. 215-242.
- [4] A. Garenne *et al.*, "A real-time closed-loop setup allowing sensory feedback driven learning strategies", submitted to *J. Neuroscience Methods*, March 2007.
- [5] *MEA System User Manual*, Multi Channel Systems, Reutlingen, Germany, May 2006.
- [6] *PGA Programmable Gain Amplifier: Technical Specifications*, Multi Channel Systems, Reutlingen, Germany, Feb. 2007.
- [7] *Stimulus Generator 2000 Series User Manual*, Multi Channel Systems, Reutlingen, Germany, May 2006, pp. 81-84.

- [8] J-M Irazabal and S. Blozis, "Application note AN10216-01", *I2C Manual*, Philips Semiconductors Inc., March 2003.
- [9] D.R. Merrill, M. Bikson, and J.G.R. Jefferys, "Electrical stimulation of excitable tissue: design of efficacious and safe protocols", *Journal of Neuroscience Methods*, vol.141, Oct. 2005 pp. 171–198.
- [10] D.A. Wagenaar, J. Pine, and S.M. Potter, "Effective parameters for stimulation of dissociated cultures using multi-electrode arrays", *J. Neurosci Methods*, vol.138, March 2004, pp. 27-37.
- [11] A. Garenne, A. Maillard, F. Nagy, and G. Le Masson, "Meanalyzer: standalone software for the analysis of multi-electrodes arrays recordings", submitted to *Neurocomputing*, Dec. 2006.
- [12] D. Henze *et al.*, "Intracellular features predicted by extracellular recordings in the hippocampus in vivo", *The Journal of Neurophysiology*, vol. 84 no. 1, July 2000, pp. 390-400.
- [13] D.A. Wagenaar, J. Pine, and S.M. Potter, "Searching for plasticity in dissociated cortical cultures on multielectrode arrays", *Journal of Negative Results in BioMedicine*, vol.5, Oct. 2006.
- [14] G. Bontorin, J. Tomas, and S. Renaud, "Low noise and low cost neural amplifiers", in *Electronics, Circuits and Systems, 2007. ICECS 2007. IEEE International Conference on*, submitted for publication.
- [15] G. Bontorin, "Bioelectronics closed-loop for hybrid neural networks: towards a fully integrated approach", Master's thesis, ENSEIRB, Bordeaux, France, Sept. 2006.

TABLE I  
COMPARISON BETWEEN HYNNET AND THE LATEST MCS SYSTEM [5-7]

	MCS	HYNNET
	PCI Connector	MC_CARD DATANUM
Analog Input	128	16/Board
Digital Input	16	*
Digital Output	16	*
Digital Input/Output	0	18*4 (DVI ports)
Data Resolution	12	12
Sampling frequency	50kHz	40kHz
	Programmable Amplifier	PGA Amplifier ACQ Board
Number of Input Channels	16,32,64	4/Board
Input Voltage	+/- 0.3 V	+/-1V
Gain	10 to 5000	1 to 127000
Noise density at 1kHz	25 nV/ $\sqrt{Hz}$	13 nV/ $\sqrt{Hz}$
Input Impedance	>10 <sup>12</sup> $\Omega$ – 8pF	>10 <sup>10</sup> $\Omega$ – 6pF
	Stimulus Generator	STG2000 STIM Board
Number of Outputs	8	4/Board
Input triggers	4	4/Board
Output	Voltage, current	Voltage
Waveforms	mono, biphasic, pulses, ramps, sine wave	monophasic, biphasic, pulses
Operation	Continuous or triggered	PC triggers
Computer Connection	Usb 1.1	i2c
Maximum Output Voltage	+/- 8V	+/- 15V