



**HAL**  
open science

## Fluorescent biosensor using whole cells in an inorganic translucent matrix

Hanh Nguyen-Ngoc, Canh Tran-Minh

► **To cite this version:**

Hanh Nguyen-Ngoc, Canh Tran-Minh. Fluorescent biosensor using whole cells in an inorganic translucent matrix. *Analytica Chimica Acta*, 2007, 583 (1), pp.161-165. 10.1016/j.aca.2006.10.005 . hal-00126687

**HAL Id: hal-00126687**

**<https://hal.science/hal-00126687>**

Submitted on 25 Jan 2007

**HAL** is a multi-disciplinary open access archive for the deposit and dissemination of scientific research documents, whether they are published or not. The documents may come from teaching and research institutions in France or abroad, or from public or private research centers.

L'archive ouverte pluridisciplinaire **HAL**, est destinée au dépôt et à la diffusion de documents scientifiques de niveau recherche, publiés ou non, émanant des établissements d'enseignement et de recherche français ou étrangers, des laboratoires publics ou privés.

# Fluorescent biosensor using whole cells in an inorganic translucent matrix

Hanh Nguyen-Ngoc<sup>(1)</sup>, Canh Tran-Minh<sup>(2)</sup>

- (1) University of Technology HCM, 268 rue Ly Thuong Kiet, Ho Chi Minh, Viet-Nam  
(2) Ecole Nationale Supérieure des Mines de St Etienne, Centre SPIN, 158 Cours Fauriel, 42023 Saint Etienne cedex 2, France [tran@emse.fr](mailto:tran@emse.fr)

## ABSTRACT

An optical biosensor based on vegetal cells entrapped in an inorganic translucent matrix and fluorescence detection has been developed. The biosensor uses *Chlorella vulgaris* immobilized in a translucent support produced from sol-gel technology. The translucence of the structure enables the algal active layer to be placed directly in contact with the optical fibers for fluorescence detection. This configuration has many advantages over the use of an opaque support because no space between the optical fibers and the active layer is required to collect fluorescence. This reagentless biosensor allows determination of diuron as an anti-PSII herbicide and its long term activity is assessed.

## KEYWORDS

Fluorescent biosensor; Cell immobilization; Sol-gel; Translucent matrix; *Chlorella vulgaris*; Herbicides detection

## 1-INTRODUCTION

Optical biosensors based on fluorescence detection often use the combination of a fluorescent bioreceptor associated with an optical transducer [1]. Fluorescent biosensors may also be obtained by immobilizing whole cells on the surface of a sensor layer. This bioactive layer is usually placed in front of the tip of an optical fibers bundle to generate a fluorescence signal. The optical fibers are required to send the excitation radiation to the fluorescent bioelement and convey the fluorescence radiation up to a fluorimeter [2]. When algal cells are deposited on the surface of an opaque support, they are placed at some distance to the optical fibers bundle to allow the fluorescence radiation emitted by the illuminated area to be collected properly [1,3]. Our previous investigation indicated that this distance must be carefully optimized because it has a major influence upon the signal amplitude and the biosensor reproducibility. This space control will be the main major drawback of those biosensors manufacturing.

In order to improve the simplicity and reliability of fluorescence based biosensors, optically translucent supports are used because their optical properties enable detection of fluorescence emitted by the algal cells even if they are entrapped in the bulk of the translucent support.

Silica matrixes have interesting properties including optical translucence, biocompatibility and chemical inertness. The design flexibility of sol-gel technique and ease of fabrication can fulfill to create the support with structural and chemical features that could be compatible with biomaterials [4-7]. While immobilization of enzymes and whole cells in sol-gel is a well known technique in biosensor application, it is not yet used for the construction of vegetal-cell optical biosensors. On the other hand, when an enzyme is immobilized, a substrate is required and a fluorescent indicator may be added to enable optical detection of the analyte [8-9]. In the case of detection based on chlorophyll fluorescence, those reagents are not necessary, and a reagentless biosensor can be constructed for toxic chemicals determination.

In this paper, translucent matrixes obtained from a sol-gel process have been investigated for entrapment of fluorescent biomaterials in order to improve the fluorescent biosensor fabrication. Vegetal cells as bioreceptors have been tested for herbicides determination.

## 2-EXPERIMENTAL

## 2.1-ALGAL CULTIVATION AND IMMOBILIZATION

*Chlorella vulgaris* strain (CCAP 211/12) was used as a bioreceptor to construct an algal fluorescent biosensor. It was purchased from The Culture Collection of Algae and Protozoa at Cumbria, United Kingdom. The axenic algal strain was grown in the culture medium and under conditions described by the International Organization for Standardization (ISO 8692). The concentration of algal cells in suspension was determined by optical density at 760 nm.

Algal cells were immobilized according to the sol-gel process. Silica sources were sodium silicate solutions (purchased from Riedel-de-Haen) and colloidal silica LUDOX HS-40 (from Aldrich). Glycerol was purchased from Aldrich. All solutions were prepared with purified water (Rios Millipore system). Sodium silicate (0.4M, 4ml) and LUDOX (8.5M, 4ml) were thoroughly mixed to obtain an homogeneous silica solution. A HCl, 4M solution was then added drop by drop until an appropriate pH is reached to induce the gelation process. Immediately, an algal solution containing  $6 \times 10^7$  cells/ml and 10% (w/w) glycerol was introduced under stirring and the resulting solution is cast in moulds to produce algal cells containing matrixes. Glycerol is added to minimize cracks in the gel microstructure and to improve the mechanical properties of the polymer. Gelation was performed at ambient temperature.

## 2.2-CONSTRUCTION OF THE BIOSENSOR

The biosensor was constructed with a removable algal membrane placed in a 1-mL home-made flow cell (Figure 1). The active membrane was obtained by sol-gel entrapment of the algal cells in a porous silica matrix. The gel was cast in a mould to obtain a membrane of 8mm in diameter and 1mm in thickness to be fitted in front of the tip of a bifurcated bundle of randomised optical fibres. The excitation light hit the upper part of the membrane and the resulting fluorescence radiation was collected up to a spectrofluorometer.

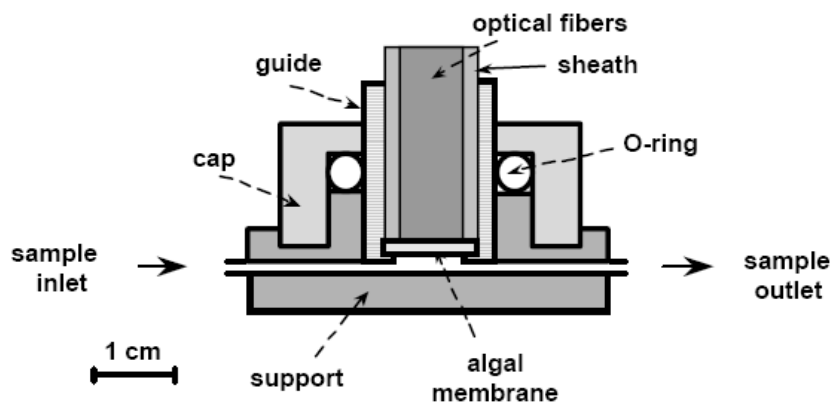

Figure 1: Fluorescence biosensor using algal cells entrapped in a silica matrix

## 2.3-FLUORESCENCE MEASUREMENTS

Fluorescence measurements were carried out with a Spex Fluorolog 2 fluorometer from Jobin-Yvon equipped with a microcomputer for data recording. The algal cells containing matrixes were illuminated with a 469-nm excitation light and the fluorescence was collected at 682 nm through an optical fiber bundle. Measurements were done in triplicate. Most experiments were performed at 20°C and pH 7. Algal membranes were adapted to darkness for 15 min before a 1-min illumination period with the excitation light. The fluorescence measurement was carried out

immediately after the membrane was illuminated. Inhibition of photosynthetic activity of algal cells was carried out with diuron [3-(3,4-dichlorophenyl)-1,1-dimethylurea]. This herbicide was of analytical grade (Pestanal) from Riedel-de-Haen. It was prepared in Milli-Q water (Millipore) to obtain stock solutions and stored in darkness at 4°C for 7 days. All test solutions were diluted in Milli-Q water immediately before use.

### 3-RESULTS AND DISCUSSION

#### 3.1-SOL-GEL PROCESS TO OBTAIN ACTIVE MEMBRANE

The sol-gel process is based on hydrolysis and condensation reactions in solution leading to the final gel in water-alcohol. It has usually been performed with alkoxide precursors TEOS (tetraethoxysilane) or TEMOS (tetraethoxysilane) using acid hydrolysis followed by immobilisation of the biocomponent at neutral pH. However, the product alcohol has a denaturing effect on the activity of some biospecies and limits the use of this encapsulation procedure [10]. To avoid the release of those products toxic to algal cells, alkoxide precursors are replaced by aqueous precursors.

#### 3.2-FLUORESCENCE BIOSENSOR CONFIGURATIONS

##### 3.2.1. Bioreceptor immobilized on an opaque matrix

A fluorescence based biosensor often makes use of a bifurcated bundle of optical fibers. Half of them send the excitation radiation to the fluorescent material and the other half collect the fluorescence emission (Figure 2A). Each fiber has an acceptance cone angle where the light can be transmitted and overlapping between excitation and fluorescence cone angles is required for the fluorescence to be measured. Therefore, if the bioreceptor is entrapped in an opaque support, a space is necessary to recover the fluorescence emitted from the illuminated area (Figure 2B), because the light cannot penetrate the support and only the superficial layer is fluorescent.

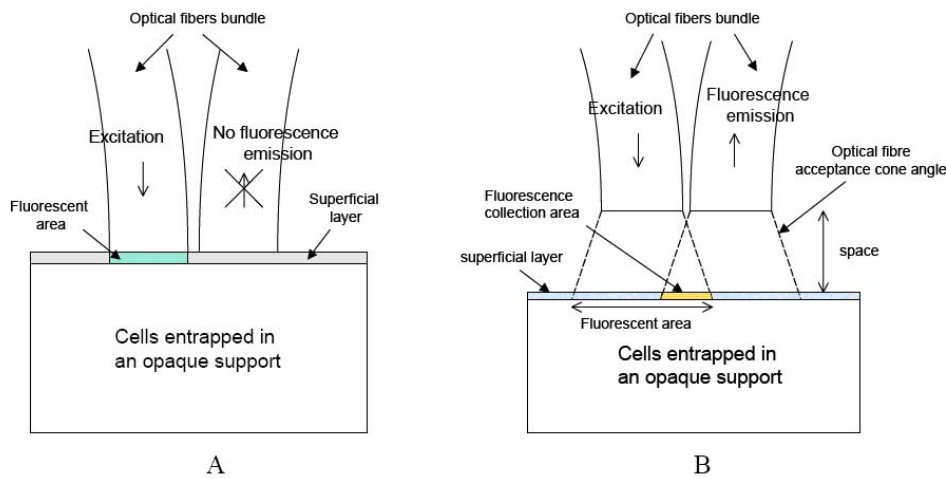

Figure 2: Schematic of optical biosensors using an opaque support containing a fluorescent bioreceptor, without (A) and with a space (B) between the optical fibers and the support

### 3.2.1. Bioreceptor immobilized on an translucent matrix

When the optical biosensor uses a translucent support, the fluorescence zone is not restricted to the surface because the excitation light can penetrate the membrane (Figure 3). Fluorescence can then be collected without any need to maintain the optical fiber away from the membrane [1]. The fact that the active layer can be put directly in contact with the support makes the biosensor simpler to be designed and manufactured. It also improves the handling and reliability of the sensor.

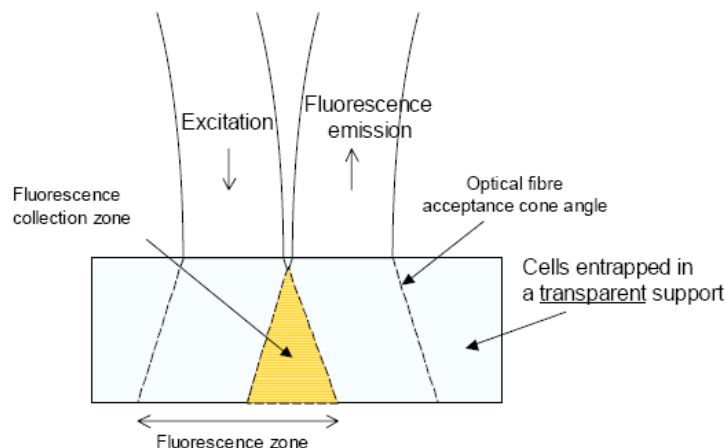

Figure 3: Schematic of a optical biosensor using an translucent support containing a fluorescent bioreceptor. No space between the optical fibers and the support is required to collect fluorescence

### 3.3-ACTIVITY OF ENCAPSULATED ALGAE

The algal cells activity is determined by measuring the vegetal chlorophyll fluorescence at 682nm, which reflects their photosynthetic activity. The fluorescence signal provides information on the fluorescence induction, particularly on the activity of the Photosystem II (PSII), which is the target of many herbicides. Since algal cells are entrapped in an insoluble support, they are no longer in their natural environment. It is also necessary to assess their activity in the presence of various compounds added during the immobilization process. Figure 4 shows that the maximal fluorescence emission wavelength ( $\lambda_{max} = 682\text{nm}$ ) of algal cells is not affected by the presence of glycerol and the silica matrix. The presence of an anti-PSII herbicide inhibits the electrons transfert in the PSII system which results in an increase in the chlorophyll fluorescence emission. In addition, the inhibition of PSII activity by herbicides is reversible [1], which is very interesting for continuous monitoring of herbicides.

### 3.4-DETERMINATION OF HERBICIDES

Herbicides determination has been a growing concern of agriculture and health care professionals and regulatory agencies. Biosensors for pollutants determination have proved to be sensitive, low cost and easily adapted for on-line monitoring [11]. In addition, biosensors using algal cells are of ecotoxicity interest because these bioreceptors are the targets of numerous herbicides. It has been commonly accepted that photosynthesis inhibition is a reliable indicator that rapidly reflects the toxic effects of pollutants [12]. About thirty percent of herbicides are targeting the vegetal PSII [13-14]. They include derivatives of phenylurea (such as diuron, isopropuron...), triazines, and phenolic herbicides. Triazines and phenylurea are well-known

herbicides that specifically fix to the binding site of PSII with high affinity. These substances inhibit photosynthetic electron flow by blocking the PSII quinone binding site and thus cause an increase in chlorophyll-a fluorescence intensity. PSII-based biosensors are reported to be able to detect those herbicides in the environment [15]. Diuron was used as an example of an anti-PSII herbicides to evaluate the performance of the fluorescence biosensor.

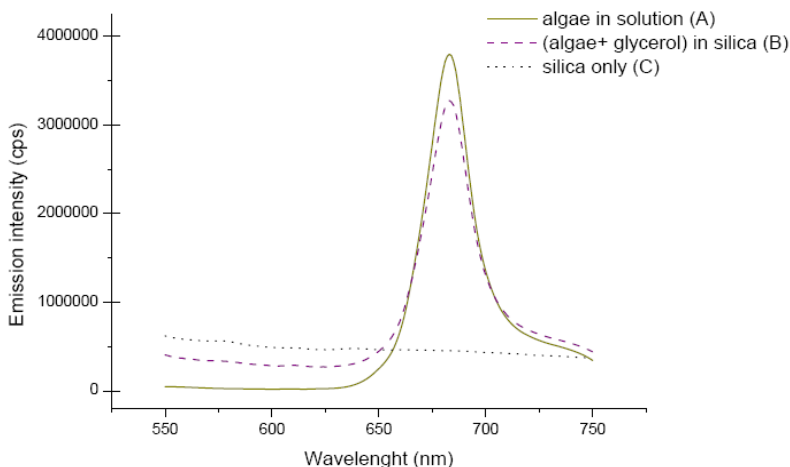

Figure 4: Algal fluorescence emission spectrum under 469-nm excitation light for *Chlorella vulgaris* ( $6 \times 10^7$  cells) in solution (A) and immobilized with 10% glycerol in a silica matrix (B), compared to a reference silica support without any cells (C)

Response of the algal biosensor was obtained from the chlorophyll fluorescence emission at 682 nm under 469-nm excitation light (Figure 4). Excitation maximum corresponds to the Soret band maximum absorption of chlorophyll-b [16] present in large amounts in green algae. Emission maximum corresponds to the main emission peak for *Chlorella vulgaris* [17-18]. The biosensor response to herbicide is measured in terms of initial fluorescence evolution (initial variation of fluorescence as a function of time:  $\Delta F/\Delta t$ ) as soon as various concentrations of herbicide is added to the sample solution. For herbicides which inhibits PSII like diuron, an increase in fluorescence was observed and the  $\Delta F/\Delta t$  can be determined after 5min. for any herbicide concentration. Figure 5 shows that a calibration curve can be obtained by plotting  $\Delta F/\Delta t$  as a function of diuron concentrations and a plateau is obtained with herbicide concentrations higher than 4 mg/L. The detection limit of this biosensor is  $1\mu\text{g/L}$  of diuron for a signal to noise = 3. It is lower than  $0.5\mu\text{M}$  ( $115\mu\text{g/L}$ ) reported with bioassays [19]. The instrument detection limit of high-performance liquid chromatography (HPLC) with diode array detector (DAD) for herbicides in water is approximately  $10\mu\text{g/L}$  [20].

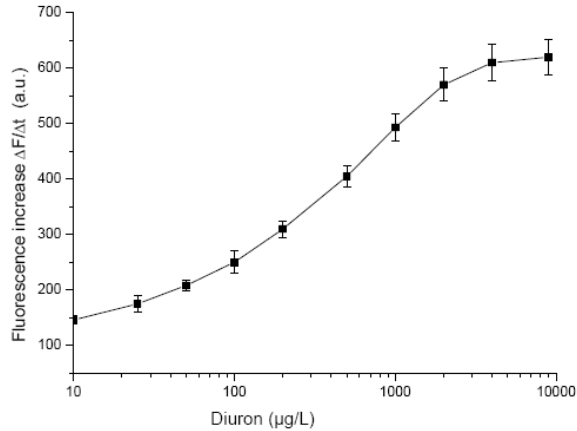

Figure 5: Response of an algal biosensor to diuron at pH 7 in terms of fluorescence evolution. Algal concentration is  $6 \times 10^7$  cells/mL

### 3.5-EFFECT OF PH

Optimal conditions (pH 7 and 20°C) are recommended for *Chlorella vulgaris* culture. In order to study the effect of pH on the algal response, the biosensor was used for 30 min under the required conditions before measurements were determined. The response to diuron was tested at 20°C in the pH range 6 to 8 (Figure 6). An optimal pH of 7 is found for this diuron concentration.

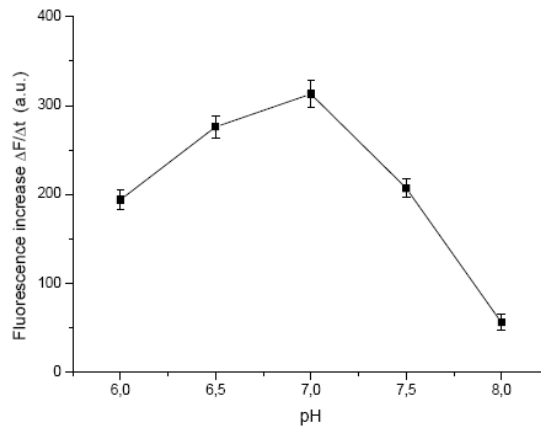

Figure 6: Response of an algal biosensor as a function of pH. Algal concentration is  $6 \times 10^7$  cells/mL, diuron concentration: 200µg/L.

### 3.6-LONG-TERM ACTIVITY OF THE ALGAL-ENTRAPPED SILICA OPTICAL SENSOR

The main objective of algal cells immobilization is to stabilise the bioreceptor for the biosensor to be used repeatedly over a long period of time and under on-line monitoring conditions.

The algal photosynthetic activity is dependent on cells concentrations: high cells concentrations give rise to higher intensity of fluorescence. The algal cells in the silica matrix keep over 95% of their initial activity after a period of 5 weeks.

## CONCLUSIONS

In this study, the interest of using an inorganic translucent matrix to construct an optical biosensor with immobilized vegetal cells is presented. *Chlorella vulgaris* whole cells were immobilized in the inner part of the translucent membrane and their activity can be assessed from chlorophyll fluorescence measurements. The translucence of the structure allowed the algal layer to be placed directly in contact with the optical fibers to produce a fluorescence emission detectable by a fluorimeter. This construction is much more simple and more reliable compared to use of an opaque support because no space between the optical fibers and the active layer is required to collect fluorescence. This improved configuration will facilitate the design of optical whole-cells biosensors and reduce their manufacturing cost. The use of this entrapment technique is motivated by the optical transparency and chemical inertness of the support. Optical properties of the silica matrix in the absence and in the presence of vegetal cells [21] justify the suitability of the method for probing other herbicides. Since this matrix has regularly uniform mesopores, the immobilized algal cells are accessible to aqueous pollutants. This technique has been applied to determination of diuron as an example of a herbicide that inhibits the algal PSII. On previous papers, we have shown that *Chlorella vulgaris* cells as a bioreceptor allowed the determination of the anti-photosystem II (PSII) herbicides group which target the algal PSII fluorescence. Therefore, this biosensor using the same bioreceptor will also respond to other PSII-inhibiting herbicides such as triazines and phenylurea derivatives.

This algal biosensor can be used up to 5 weeks without significant loss of activity. In addition, this whole-cell reagentless biosensor based on chlorophyll fluorescence detection is economically very interesting because it requires neither substrate nor fluorescent indicator to monitor herbicides levels in the environment. This fluorescent biosensor also compares favourably with enzyme biosensors for the determination of herbicides because *Chlorella vulgaris* can be easily cultivated and no enzyme purification step is needed. While determination of herbicides is possible with other chromatographic techniques, only this type of biosensor can continuously monitor their concentrations. This optical algal biosensor could also be used as an early-warning device to detect those pollutants. Performance and optimization studies with other herbicides are under way and the results will be compared to other analytical techniques.

## ACKNOWLEDGMENTS

This work has been supported by Region Rhône-Alpes under a "Thematic Program" and a MIRA fellowship granted to Dr Hanh Nguyen-Ngoc for her stay at Ecole des Mines. The authors appreciate Dr. C. Durrieu, Dr. M. Naessens and Prof. J.M. Chovelon for fruitful discussions and A.M. Danna for experimental assistance.

## REFERENCES

- [1] M. Naessens, J.C. Leclerc, C. Tran-Minh, *Ecotoxicol. Environ. Saf.* 46 (2000) 181.
- [2] B. Hong, K.A. Kang, *Biosens. Bioelectron.* 21 (2005) 1333.
- [3] C. Védrine, J.C. Leclerc, C. Durrieu, C. Tran-Minh, *Biosens. Bioelectron.* 18 (2003) 457.
- [4] B. Dunn, J.M. Miller, B.C. Dave, J.S. Valentine, J.I. Zink, *Acta Mater.* 46 (1998) 737.
- [5] S. Fennouh, S. Guyon, C. Jourdat, J. Livage, *C.R.Acad.Sci. Paris Ser. IIc* (1999) 625.
- [6] J. Livage, T. Coradin, C. Roux, *J. Phys.: Condens. Matter* 13 (2001) R673.



- [7] F.G. Sanchez, A.N. Diaz, M.C. Ramos Peinado, C. Belledone, *Anal. Chim. Acta* 484 (2003) 45.
- [8] R.A. Doong, H.C. Tsai, *Anal. Chim. Acta* 434 (2001) 239.
- [9] HC. Tsai, R.A. Doong, H.C. Chiang, K.T. Chen, *Anal. Chim. Acta* 481 (2003) 75.
- [10] A. Coiffier, T. Coradin, C. Roux, O.M. Bouvet, J. Livage, *J. Mater. Chem.* 11, (2001) 2039.
- [11] K.R. Rogers, *Biosens. Bioelectron.* 10 (1995) 533.
- [12] J. Overnell, *Mar. Biol.* 38 (1976) 335.
- [13] D.E. Moreland, *Annu. Rev. Plant. Physiol.* 31 (1980) 597.
- [14] W. Draber, K. Tietjen, J.F. Kluth, A. Trebst, *Angew. Chem. Int. Ed. Engl.* 30 (1991) 1621.
- [15] M.T. Giardi, M. Koblizek, J. Masojidek, *Biosens. Bioelectron.* 16 (2001) 1027.
- [16] M.F. Hipkins, N.R. Baker, in: M.F. Hipkins, N.R. Baker (Eds.), *Photosynthesis energy transduction. A practical approach.* Irl press, Oxford, 1986, p. 51.
- [17] Govindjee, K. Satoh, in: Govindjee, J. Amesz, D.C. Fork (Eds.), *Light emission by plants and bacteria.* Academic press, inc, Orlando, 1986, p. 497.
- [18] D. Frense, A. Müller, D. Beckmann, *Sens. Actuat. B* 51 (1998) 256.
- [19] R. Conrad, C. Büchel, C. Wilhem, W. Aarsalane, C. Berkaloff, J.C. Duval, *J. Appl. Phycol.* 5 (1993) 505.
- [20] S.R. Ruberu, W.M. Draper, S.K. Perera, *J. Agric. Food Chem.* 48 (2000) 4109.
- [21] H. Nguyen-Ngoc, C. Tran-Minh, *Mat. Sci. Eng. C* , in press.