

# ENERGY DEPOSITED BY NEUTRONS AND GAMMA RAYS IN THE CRYOGENIC SYSTEM OF SISSI

E. Baron, L. Bianchi, J. Dural<sup>(\*)</sup>, C. Grunberg and A. Joubert  
GANIL, BP 5027 - F-14021 Caen Cedex

## Abstract

SISSI is an ion-optical system consisting of two cryogenic solenoids separated by a target which produces secondary particles under the impact of intense heavy ion beams. Besides the problem of shielding the cryogenic parts against the heat and the charged particles coming from the target, care must be taken of the power deposited in the solenoid windings by neutrons and gamma rays ; although this power is supposedly very small, the cooling capacity of the closed cycle refrigerator (a few watts) must take it into account. Measurements were made by means of a calorimeter simulating the windings and traversed by the neutral particle fluxes produced by C, N, Ne and Ar beams hitting C and Ta targets ; the results are presented and compared to approximate theoretical predictions.

## 1. INTRODUCTION

SISSI (Source d'Ions Secondaires à Supraconducteurs Intenses)<sup>[1]</sup> is a device intended for producing radioactive ion beams and ensuring their optimal transmission in the existing GANIL beam lines. It consists of a target located between two superconducting solenoids : the upstream lens focuses the heavy ion beam on the target and the radioactive ions generated subsequently are taken care of by the downstream lens (figure 1). Both solenoids are strongly convergent in order to produce a very small spot size on the target and to collect the secondaries within as large a solid angle as possible ; since magnetic fields up to 11 teslas are required, use is made of superconducting windings (Nb<sub>3</sub>Sn and NbTi). In order to avoid container handling and to save on operation cost, the cooling is provided by a closed circuit of liquid He at 4,6K with a limited power capacity (3.5 watts) ; once the thermal losses of the cryogenic system itself are subtracted, only 1 watt is left for the power brought by all the radiations coming from the target : heat, charged and neutral particles. In the following, we will restrict the subject to neutrals : the problems due to the two other sources of energy can be handled by well-known techniques. As for the target, which may be chosen in a variety of solid materials, it could be interesting in some situations to have it thick enough to fully stop the incident beam.

A first approach of the problem consisted in an estimate based on calculated neutron spectra, using an absorption method ; the surprisingly high values obtained for the power absorbed in the windings led us to check them through an experimental technique which had to be carried out with the present GANIL beam power, i.e. 400 watts for 95 MeV/n beams (as compared to 10 kW in a near future), on a low temperature copper model. The results were then extrapolated to the full scale model and compared to the estimates. In addition, the screening capabilities of a number of materials were measured, which helped to choose a composite shield for the cold parts of the solenoids.

<sup>(\*)</sup> CIRIL , BP 5133 - 14040 Caen Cedex, France

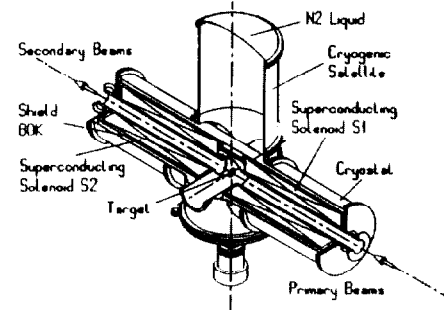

Figure 1 SISSI : general layout

## 2. THEORETICAL APPROACH

### 2.1. Neutron spectra

The differential cross-sections for neutron production in heavy ion collisions can be reasonably predicted by the ONRL HIC1 code [2] as was shown by Tuyn and al [3]. Two cases were investigated with this tool : 95 MeV/n <sup>12</sup>C and <sup>20</sup>Ne beams intercepted by carbon targets ; in each case, two situations were considered : a) the target thickness is at least equal to the projectile range or b) the thickness is such that only 10% of the beam power is left in the carbon. Figure 2 shows the calculated differential cross-sections  $\sigma''(\theta, E)$  per steradian and MeV neutron energy interval as a function of the neutron energy  $\bar{E}$  and the azimuth  $\theta$  in the laboratory system for <sup>12</sup>C ions hitting a thin C target. It is then easy to calculate the average number of neutrons  $n_t$  per incident ion, the mean neutron energy  $E$  and, given the ion beam intensity  $I$ , the total neutron power  $P$  released in the region of space occupied by the downbeam solenoid. Lines 1 to 3 of table 1 show the results : for a 10 kW ion beam, several tens to a hundred watts are expected only due to the neutrons, and it is therefore justified to try to estimate what fraction of this power can be left in the cold parts of the device.

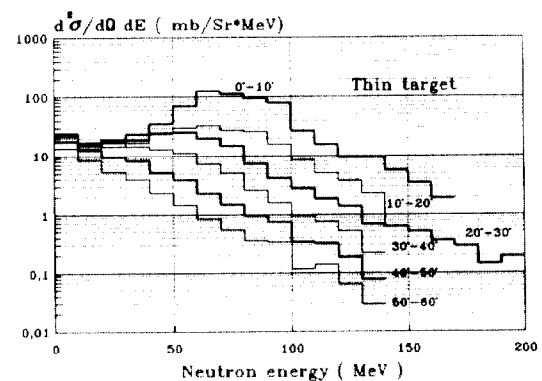

Fig.2 : Neutron energy spectrum from the <sup>12</sup>C(C<sup>12</sup>, xn) reaction in the laboratory system at 95 MeV/nucleon

	C→C thin	C→C thick	Ne→C thin	Ne→C thick	
$n_{\nu}/\text{ion}$	0.095	0.505	0.087	0.429	just
$\bar{E}$ (MeV)	43.0	29.8	43.8	34.1	behind
P(watts)	35.8	132.3	22.0	76.9	the target
$n'_{\nu}/\text{ion}$	0.045	0.222	0.040	0.180	after
$\bar{E}'$ (MeV)	39.0	27.9	45.5	33.4	absorption
P'(watts)	15.5	54.4	9.6	31.5	by solenoid
$\delta P$ (watt)	20.3	77.9	12.5	45.4	

Table 1 : Computed neutron power absorbed in the solenoid for 10 kW, 95 MeV/n beams and the geometry of figure 3. "Thin" targets correspond to a 1 kW absorbed power.

2.2. Estimate of the absorption

A simple method for handling the problem is to consider the neutron flux as being exponentially attenuated with the distance travelled in the material, a current technique in accelerator shielding ; this requires the knowledge of the attenuation length  $\lambda(E)$  as a function of the neutron energy and, while only scarce data are available for energy up to 15 MeV in materials like concrete or iron, it appears that, for high energy neutrons, this quantity can be deduced from the inelastic cross-sections. We have used a compilation proposed by M. Langevin<sup>[4]</sup> for iron : this metal was considered as being the only constituent of the cold parts of the solenoid in place of Nb<sub>3</sub>Sn, NbTi, both with 50% Cu for the windings, and of stainless steel for the structure. Therefore, after dividing the region of space of interest in parts of average thickness  $L(\theta)$ , (figure 3), the new characteristics  $n'_{\nu}$ ,  $\bar{E}'$  and  $P'$  of the neutron flux behind the absorbing elements can be calculated just by multiplying the elementary cross sections  $\sigma^*(\theta,E)$  by the corresponding attenuation factor  $\exp\{-L(\theta)/\lambda(E)\}$ . Lines 4 to 6 of table 1 show the results and line 4 exhibits the power difference  $\delta P = P - P'$  left in the solenoid : depending on the target thickness, it may range from one to several tens of watts for a 10 kW beam power at 95 MeV/nucleon. These impressive figures, although obtained through a crude method, led us to check them by an experimental method.

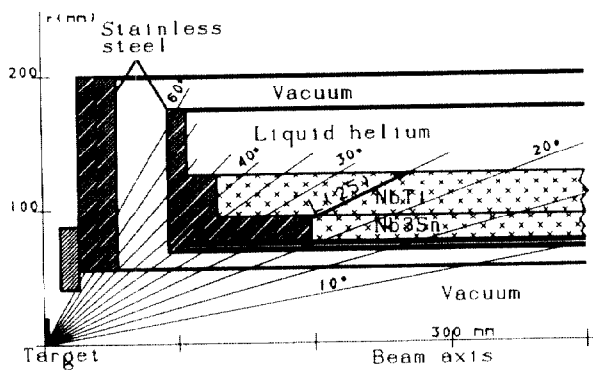

Fig. 3 : Cross-sectional view of the solenoid

3. EXPERIMENTAL METHOD

The experimental set-up is schematically presented on figure 4 ; it consists of : - a target (thick enough to completely stop the beam), located in a Faraday cup which itself stops all the charged secondaries and - a copper cylinder, located in a cryostat composed of a liquid nitrogen-cooled outer screen and a container in which an adjustable helium gas flow is established. The initial operating temperature of the model can be set to anything between 4K and several tens of K ; therefore, due to the low heat capacity of copper in these conditions, a small fraction of watt causes a measurable temperature variation. The copper temperature is measured by a very precisely calibrated resistor ; in addition, the cylinder can be heated and, in some circumstances temperature-controlled by an imbedded heating resistor.

Two methods were used to measure the power left by the neutrons in the copper model :

a) the temperature variations are recorded versus time for a zero He gas flow with, and then without the ion beam bombarding the target ; in this second situation, the same measurement is repeated with injection in the model of known powers through the resistor in order to get a set of calibration curves. A simple interpolation leads to the result. The conditions for reliability are 1) identical initial temperatures and 2) constant ion beam intensity versus time.

b) for a fixed gas-flow, the temperature regulation is turned on and the power dissipated by the resistor is recorded on both situations : beam on and beam off. This method cross-checks a) within about 4%.

The results had to be corrected for the absorption by the 26mm thick copper Faraday cup ; using the method exposed in the previous paragraph, it was found that 20% of the neutron power is lost there. As for the gamma rays, due to their much lower energy spectrum and attenuation length, it has been estimated that they give no contribution to the temperature rise of the model.

The measurements were repeated after inserting various screens between Faraday cup and cryostat in order to estimate their absorption capabilities.

Finally, a check was made on the thermal behaviour of liquid helium just by filling up the cryostat (1,5 litre) after removal of the copper cylinder ; with the help of a gas meter, it was established that there was no flow difference between the beam on and beam off situations, and therefore negligible absorption.

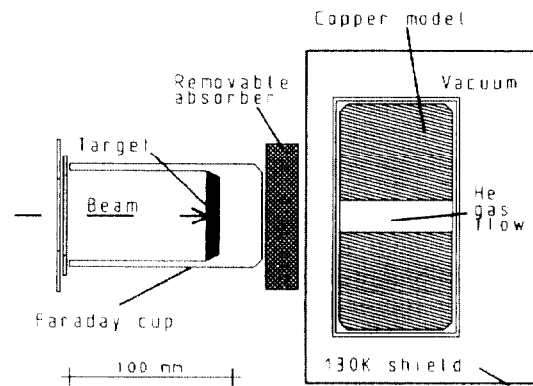

Fig. 4 : Schematic view of the experimental set-up

in2p3-00666107, version 1 - 3 Feb 2012

#### 4. RESULTS AND DISCUSSION

Four beams were used :  $^{12}\text{C}$ ,  $^{14}\text{N}$ ,  $^{20}\text{Ne}$  and  $^{36}\text{Ar}$ , all of them with an energy of 95 MeV/nucleon and an intensity corresponding to a power of 400W, while the targets were either carbon or tantalum ; the measured powers, once corrected as mentioned previously, are given in table 2. In two cases (thereafter referred to as "the test cases") : C and Ne beams with a C target, a comparison is made with the results of the estimates carried out as in paragraph 2 with the geometry of the model ; it appears fortunately that there is an overestimate by a factor of 4.5 and 2.4 respectively. Therefore, one can be assured that such a calculation, when worked out for any projectile-target couple, will provide an exaggerated value for the absorbed neutron power.

Interaction	P(measured) watts	P(estimated) watts	Overestimate Pcalc/Pmeas
C→C	0.366	1.639	4.5
N→Ta	0.215		
Ne→C	0.394	0.949	2.4
Ar→C	0.144		
Ar→Ta	0.098		

Table 2 : Neutron power absorbed in the model for 400W, 95 MeV/n beams and the geometry of figure 4. All targets are at least as thick as the range of the ions.

However, although not accurate for obtaining absolute values, this method is still useful to find the scaling factor between the geometries of the model and of the full-scale solenoid : a value of 1.9 was found for both test cases. In the same manner, it was used to calculate the ratio between the neutron power released by a thin target (as defined earlier) and a thick one : again, the two results converged toward a common value of 0.26 (within 4%). When applied to the experimental results these two factors led to the figures of table 3, where adjustment was made also to a 10 kW beam power : it is seen that, in no situation, the cryogenic system can withstand a 95 MeV/n heavy ion beam.

Projectile	Target	P(watts) thick	P(watts) thin
C	C	17.3	5.2
N	Ta	10.3	2.9
Ne	C	18.8	5.2
Ar	C	6.1	2.0
Ar	Ta	4.2	1.4

Table 3 : Neutron power absorbed in the solenoid for 10 kW, 95 MeV/n beams. "Thin" targets correspond to a 1 kW absorbed beam power.

It remained to control if screening against neutrons in the available space between the target and the solenoid can bring the power figures down ; table 4 summarizes the results obtained in the calorimeter (N.B. the cadmium plate was only 3mm thick) ; although no attenuation lengths can be drawn from these values, several comments have to be made :

- the 18% fraction absorbed by Cd represents the thermal fraction of the spectrum ; such a screening factor can therefore be readily applied to the figures of table 3 if the inside part of the solenoid is coated with such a skin,

- for plexiglas, there is probably an additional attenuation due to the larger thickness as compared to Cd,
- during the run when Cu and Pb were tested, an instability in the circulating He pump caused fluctuations in the results which are therefore only indicative,
- the 15% absorption by Al is identical to the result of the estimate for a 20mm thickness of Fe.

Screen	Interaction	Absorption (%)
Cd	N→Ta	18.6
Al	N→Ta	15
Pb	Ar→C	≈ 20
Cu	Ar→C	≈ 27
Plexiglas	Ar→Ta	24

Table 4: Neutron power absorbed by several 20mm thick screens.

Consequently, we adopted the idea that any metal screen occupying part of the beam pipe would bring an appreciable attenuation ; using the  $\lambda(E)$  of the paragraph 2, attenuation factors ranging from 2.25 to 2.45 were found for the massive shield we could design ; copper will be used since in addition, it is easy to watercool if necessary. With these factors in hand, most of the figures of table 3 are brought down to 2 watts or less for thin targets, which means that in some cases, either the beam power or the target thickness will have to be reduced by a factor which is no higher than 2. As for the thick targets, at least for the cases studied here, the idea of using them must be abandoned.

#### 5. CONCLUSION

The experimental results show that the neutron power dissipated in the cold-temperature parts of SISSI can be reduced to a level comparable to the maximum tolerable value under the condition that these parts are shielded by a double layer : a thin cadmium foil wrapped around a more massive copper piece. However, this is only possible if the target thickness is such that it stops no more than 0.5 to 1 kW of incoming beam at 95 MeV/nucleon. On the other hand, the results given by the theoretical model are overestimated by a factor of several units.

#### Acknowledgements

The authors wish to thank F. Levesque, D. Lelievre and J.M. Ramillon for their efficient help in preparing and running the experiments. The theoretical part of this work could not have been possible without the availability of the numerous spectra calculated by F. Hubert who kindly let us use her results.

#### References

- [1] - A. Joubert, E. Baron, C. Grunberg, D. Larson, W. Mittag and F. Ripoutau. "The SISSI project : an intense secondary ion source using superconducting solenoids", I.E.E.E. Particle Accelerator Conference Proceedings, Vol. 1, San Francisco, U.S.A., May 1991, p.594.
- [2] - H.W. Bertini, ONRL. Report/TM-5161, 1976 and Phys.Rev. C14,2,pp.590-595, 1980.
- [3] - J.W. Tuyn et al, CERN Reports HS-RP/TM/80-S, HS-RP/TM80-68 and HS-RP/TM/80-70, 1980.
- [4] - M. Langevin, private communication.