

GANIL D.C. POWER CONVERTERS : IMPROVEMENTS OF THE RESPONSE TO MAINS FLUCTUATIONS,
 MAINS VOLTAGE HARMONIC FILTERING

G. DUGAY and GANIL POWER Supply Group
 GANIL - B.P. 5027 - F 14021 CAEN CEDEX

SUMMARY

After a brief review of the methods used to simulate the mains steps, we describe the modifications brought to our DC Converters in order to protect them against the mains fluctuations. It was mostly necessary to avoid the disjunctions due to the excessively sensitive protective and relay systems and to improve the time-response of the electronic drive stages.

The second part deals with the description of a 20 KV two cells harmonic filter used to reduce voltage distortions on the 20 KV GANIL network.

1. INTRODUCTION

Ganil is composed of three cyclotrons connected in cascade, an analysing spectrometer and a beam distribution system (9 experimental rooms).

The big SSC magnets, dipoles and Qpoles are powered by more than 420 D.C Converters bought from various european makers. Among these :

- 40 converters (from 30 KW to 1 MW) are current regulated by thyristor phase control.
- All the others are Series-transistor controlled.

2. CONVERTERS RESPONSE TO MAINS STEPS

The experience gained during the first two years of beam operation showed that beam was often lost for many hours after disjunctions of some PC (power converters) or variations of magnetic field. The accelerator tuning had to be done again mostly due to a necessary recycling of the cyclotron magnets. All these disturbances were themselves caused by short mains fluctuations occurring during stormy weather.

In 1984, we decided to systematically try to locate faults inside the power supplies and to fix the problem. Due to the random character of these mains fluctuations we had to find a way to simulate them.

2.1 Simulation of mains perturbations

3 kinds of simulations were used :

- a. on the 380 V mains feeding the P.C to be tested we introduced series impedances (fig 1) either on the 380 V power circuit or 380 V auxiliary circuit or both.
- b. The same method was used on the internal 20 KV network i.e. affecting the whole facility.
- c. The third method was purely electronic. It consists in sending a voltage pulse to the input of thyristor gate control for thyristor converter or to the base of power transistors for series transistor regulated converter (fig 2 and 3). The absolute value of this pulse amplitude should be the same as the one that would be seen at the injection point if the perturbation were real. The pulse level is calculated taking into account the operating converter level and the V_{output} to V_{drive} transfer function.

With careful calibration, this method proved to be very convenient and accurate - in fact it was used most of the time.

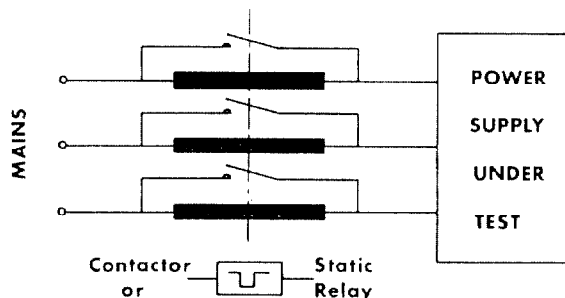

Fig 1 Simulation of mains deeps

2.2 Mains steps level

It has been found by observing the real mains steps on the 90 KV network feeding GANIL that in most of the cases the voltage fluctuations had an amplitude of :

- < 40 % when only one phase was involved
- < 25 % when occurring on the 3 phases simultaneously

The average duration being in the order of .2 to .4 second.

We therefore concentrated on these perturbation levels.

It is to be mentioned that foreseen improvements were only possible due to the fact that the power transformers had a sufficient voltage margin.

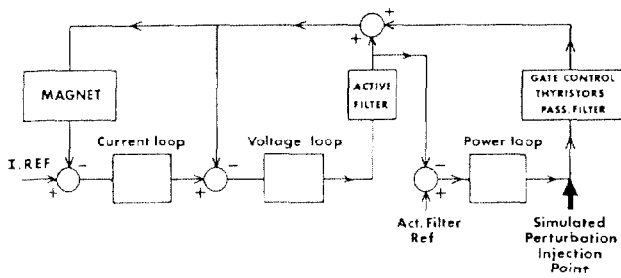

Fig 2 Block-diagram of a thyristor converter showing the perturbations introducing point

2.3 Origins of the power converters disturbances

a. Disjunctions

Main power switches or contactors energized by 220 V were generally not able to withstand mains deeps of the order of 30 %. We chose to feed them with 220 V from an inside U.P.S. (Uninterruptible power supply) network.

b. Converters protective systems

They were often disturbed by drops on +/- 24 V DC auxiliary voltages. On thyristor converters these voltages are given by a 220/18 V AC transformer also used for pulse synchronization, therefore it was impossible to use the GANIL U.P.S. network to maintain the voltages. Lack of room and required intensities (of more than 1 A) did not allow the use of a capacitor bank. Finally the +/- 24 V auxiliaries were secured by two floating charged Ni-Cd batteries.

c. Sensitivities of the protections

In addition, some protections like saturation detection, phase failure detector, ripple, earth fault had to be delayed and tuned again.

d. Improvement of control electronics

On thyristor converters we should note that the active filter was not able to deal with mains perturbations larger than 1 % and, of course, corrections had to be done on the power loop.

But we found this power loop having poor performances caused by :

- too low an open loop gain inside the 10 Hz - 100 Hz frequency band,
- some Op Amps working near saturation (12 - 13 V for $V_{CC} = 15 V$),
- integrators or P.I. amplifiers having large voltage swings and therefore storing too much energy during mains steps.

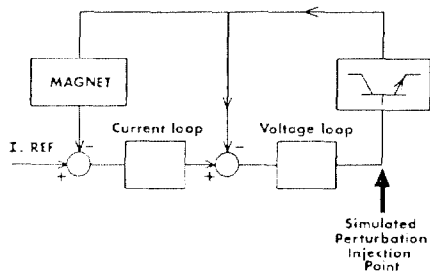

Fig 3 Block-diagram of a series-transistor converter

As a consequence, when mains voltage was resuming to its rated value the electronics became fully saturated, control lost and over-current was detected, resulting in power disjunction.

On the whole, we had to increase the open loop Gain x Bandwidth product while not taking any risk of saturating any Op. Amp.

However, increasing the gain-bandwidth product was not always possible since it sometimes led to loop instabilities during start-up and at low level operation. So, we rather used a non linear way to increase amplification. See Fig 4. This new circuit gives a fast response to mains perturbations and it has no effect on "normal" control signal ; the Zener-resistor-diode network prevents any charge of C1 capacitor above what is necessary.

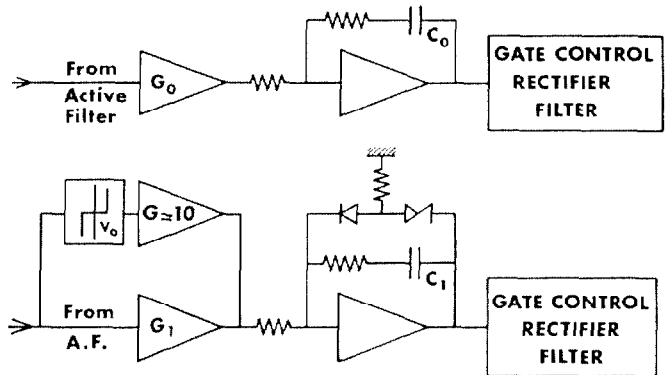

Fig 4 Thyristor converter powerloop
a. before modification
b. after modification

- $G1 \approx 3G0$
- $C1 \approx 0.5 C0$
- $V0 \approx 2 \text{ to } 3 V$

Remarks :

- On GANIL thyristor converters mains steps do not lead to pulses desynchronization.
- On transistor regulated converters the same kind of adjustments were also needed - specially limitations of voltage swings and augmentations of open loop gain and bandwidth.

2.4 Results

With all these improvements :

- unwanted converters disjunctions disappeared,
- we strongly reduced the DC voltage variations of the GANIL power converters. For example on SSC1 main magnet and with a 3 phase - 20 % - 500 ms perturbation we obtained the results illustrated on Fig 5.

On the other hand for this same step SSC1 magnetic field variation which used to be 7 Gauss is now around .3 Gauss ($B = 16000 G$). On GANIL as a whole, a loss of beam and retuning of the machine after a mains perturbation is now reduced to approximately half an hour.

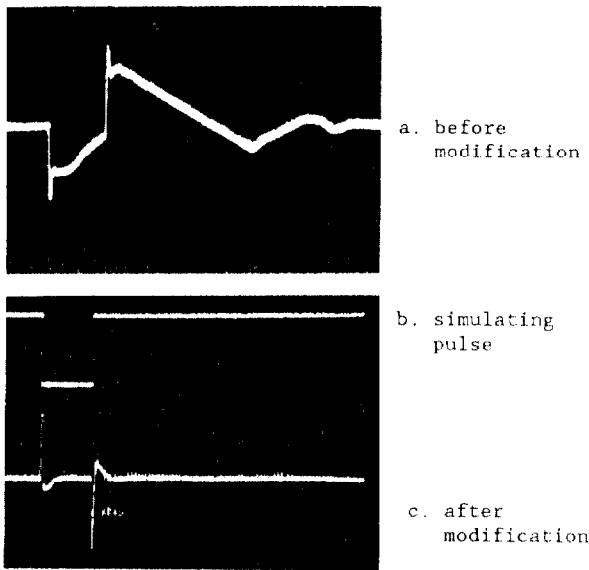

Fig 5 P.C. output voltage with simulated perturbation

3. HARMONIC FILTERING

In addition to mains fluctuation problems GANIL P.C suffered from heavy mains harmonic distortions (generated by the converters themselves).

Among others disturbances we can notice :

- phase noise in voltage or power loops of the thyristor converters,
- disjunctions produced by detection of saturation or excessive ripple on the active filter (thyristor P.C),
- excessive heating of power transformer and filtering cells (series transistor P.C).

Furthermore, GANIL power consumption during operation ranges from 5 to 8 MW while reactive power fluctuates from 6 to 9 MVA (according to the energy required).

It was decided to lower the reactive power consumption with a compensator which would also achieve harmonic filtering.

The network and filter configuration is shown on Fig 6. It should be mentioned that the 90 KV short-circuit capacity is about 400 MVA (+/- 50 MVA).

Only harmonics 11 and 13 (and with less sharpness H23 and H25) were in fact disturbing the GANIL power converters.

Harmonics 3 and 5 are not generated by GANIL, they are pre-existing on 90 KV external distributor network. However to avoid antiresonance with this network reactance a H5 filter has to be installed and the filter H11/13 should not work without the H5 in service.

Therefore two third order, low Q factor resonant filters are used in parallel [3]:

- The first one tuned on 275 Hz (H.5.5) features :

$Q_{fact} = 2$	Reactive power = 3 MVAR
	\sum losses = 5 KW
	- The second one tuned on 575 Hz (H11.5)
$Q_{fact} = 4$	Reactive power = 2.4 MVAR
	\sum losses = 1.5 KW

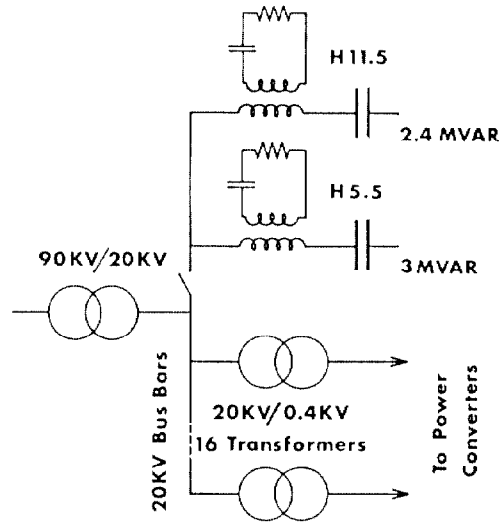

Fig 6 Network and A.C. filter configuration

Results :

As can be seen on Fig 7 the two third order filters give appreciable results in reducing harmonic distortion.

However a slight increase of H3 is observed and until now we have some reliability problems with 20 KV capacitors.

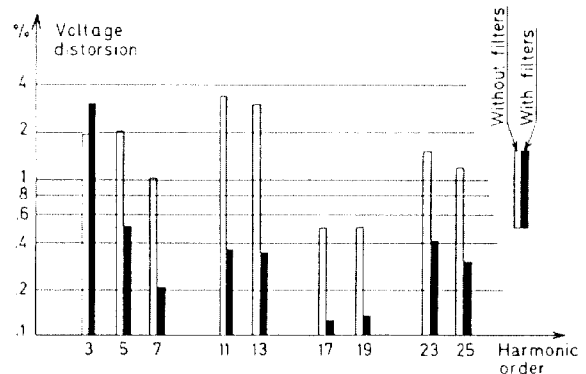

Fig 7 Filter attenuation

Acknowledgement

We gratefully thank E.D.F. (Electricité de France) particularly Mrs BERNARD from C.I.M.E NORMANDIE - PARIS and Mr PLANCHE [2] from D.E.R. for the help and advices they gave us for the improvements of our power converters.

REFERENCES

- [1] Desensibilisation des alimentations aux perturbations secteurs. GANIL internal Report R/17.86/ml.
- [2] R. PLANCHE : Insensibilisation du GANIL vis-a-vis des creux de tension - résumé des actions - Bilan et conclusion. E.D.F. Rapport HM562614RP/HS June 86.
- [3] Maitrise des harmoniques dans les réseaux industriels JP CAMATTE -G LE CAM CGEE-ALSTHOM CIRED Congress April 1983 Liege (Belgium).