

METRIC FORMULAE FOR NONCONVEX HAMILTON–JACOBI EQUATIONS AND APPLICATIONS.

A. MARIGONDA AND A. SICONOLFI

ABSTRACT. We consider the Hamilton–Jacobi equation $H(x, Du) = 0$ in \mathbb{R}^n , with H non enjoying any convexity properties in the second variable. Our aim is to establish existence and nonexistence theorems for viscosity solutions of associated Dirichlet problems, find representation formulae and prove comparison principles. Our analysis is based on the introduction of a metric intrinsically related to the 0–sublevels of the Hamiltonian, given by an inf-sup game theoretic formula. We also study the case where the equation is critical, i.e. $H(x, Du) = -\varepsilon$ does not admit any viscosity subsolution, for $\varepsilon > 0$.

KEYWORDS: nonconvex Hamilton–Jacobi equations, viscosity solutions, Aubry–Mather theory.

MSC CLASSIFICATION: 49L25.

1. INTRODUCTION

The paper is devoted to the study of the Hamilton–Jacobi equation $H(x, Du) = 0$, posed on \mathbb{R}^n or on open subsets of it, with H continuous in both arguments and coercive in the second, but not enjoying any convexity property in the momentum variable. The investigation takes place in the framework of viscosity solutions theory, from now on the term (sub, super) solution must be understood in this sense. The scope is to establish existence and nonexistence theorems for viscosity solutions of related Dirichlet problems, find representation formulae and prove comparison principles. The appeal of the topic is witnessed by some very recent contributions, see [6], [12], but our approach follows more closely the line of thought of [10].

The study of nonconvex Hamilton–Jacobi equations is a quite unexplored fields which is interesting from a theoretical point of view as well as in view of applications: for instance the time-dependent Hamilton–Jacobi equations with homogeneous Hamiltonians describe the geometric motion of interfaces which can be used to modelize phenomena arising in combustion theory, and in some situations the convexity assumption on the Hamiltonian seems not justified. Nonconvex Hamiltonians also arise in some neuronal–fiber tracking models, based on magnetic resonance imaging, where they are used to describe anisotropic diffusion of water molecules along the neurons of the brain.

A more theoretically relevant research topic for nonconvex Hamiltonians is the qualitative analysis of the critical equations which is related to homogenization

Date: January 24, 2011 – Preliminary version.

2000 Mathematics Subject Classification. 49L25.

Key words and phrases. Nonconvex Hamilton–Jacobi equations, viscosity solutions, Aubry–Mather theory.

problems as well as to dynamical issues, at least when the Hamiltonian is sufficiently regular. We will come back on this point later on.

Compared to the case of convex or quasiconvex equations, where a quite complete body of results is available, very little is known on the subject, and the difficulty of the analysis increases drastically in the nonconvex environment.

The main reason of such a gap is that when the 0-sublevels of the Hamiltonian are convex, an intrinsic Finsler metric, denoted by L , can be defined on \mathbb{R}^n through minimization of some line integrals, containing the support function of the sublevels, along the (Lipschitz-continuous) curves connecting two given points, see Definition 3.2 and [10].

The formula defining L is easy to handle and it turns out that the class of viscosity (or equivalently a.e.) subsolution to $H = 0$ is singled out by the property of being 1-Lipschitz continuous with respect to L , or, in other terms $L(x, \cdot)$ is, for any fixed x , the maximal subsolution vanishing at x , and consequently is also solution in $\mathbb{R}^n \setminus \{x\}$. In addition a Lax-type formula involving L and a datum assigned on some compact subset K , say g , provides a solution to $H = 0$ outside K taking the value g on K , provided that g satisfies some compatibility condition with respect to L . We will come back on this issue later on.

If no convexity conditions are assumed on the 0-sublevels of H , it has been proved in [10] that a related metric, indicated by S , can still be defined, and as in the convex setup, the functions $S(x, \cdot)$, for $x \in \mathbb{R}^n$, make up a class of fundamental solutions of $H = 0$, more precisely they are solutions in $\mathbb{R}^n \setminus \{x\}$ and subsolutions in the whole space.

On the other hand, they do not enjoy any maximality property and no characterization of the subsolutions to the equation in terms of Lipschitz-continuity with respect to S is available. Furthermore S is represented by a rather involved inf-sup formula of game-theoretic type, see Definition 3.1.

The metric counterpart of the lack of convexity lies in the fact that S is not of Finsler type and not even a path metric, in the sense that the distance between two points is not in general given by the infimum of the intrinsic length of curves joining them, where the intrinsic length is the total variation of the the curve with respect to S . This peculiarity adds a further complication in the analysis.

When the Hamiltonian is independent of the state variable, or more generally when the convex hull of the 0-sublevels of H is constant, say C , then the nonconvex metric coincides with the convex one supplied by C , see Proposition 3.3, more precisely

$$S(x, y) = \sigma_C(y - x) \quad \text{for any } x, y,$$

where σ_C stands for the support function of C . Part of the results contained in [4], [6] can be understood taking into account this property. However, even in this simple case, the Lax-type formula valid for quasiconvex Hamiltonian does not give in general a solution to the Hamilton-Jacobi equation in a given open region of \mathbb{R}^n when a boundary datum g is assigned, as it is shown in Example 3.1. We propose an appropriate adaptation of this formula to the nonconvex setting, see (7) and Theorem 4.1, but then an interesting issue arises, namely to determine compatibility conditions on g in order that the solution so obtained agrees with it on the boundary and no boundary layers develop.

In the convex case a necessary and sufficient condition for this is the 1-Lipschitz continuity of g with respect to the intrinsic metric L . In the absence of convexity

properties this is not true any more, even if we replace L by the nonconvex metric S . This is demonstrated for a class of affine boundary data in Proposition 5.1, which slightly generalizes a result given in [4], and for a datum of different nature in Example 5.2.

We do not know if in the nonconvex setting a not too involved characterization of admissible boundary data can be detected. So far, we provide different sufficient conditions for this in Section 5, in particular Proposition 5.4 should be compared to Theorem 2.6 in [4] and Theorem 7 in [6]. A couple of uniqueness principles in the case where the 0-sublevels of H are strictly star-shaped with respect to 0 are established as well, see Propositions 5.7, 5.8.

In Section 6 we deal with the case where the equation $H(x, Du) = 0$ is critical, i.e. it admits subsolution in \mathbb{R}^n but no functions ψ satisfying $H(x, D\psi) \leq -\varepsilon$ in the viscosity sense, can exist, for any positive ε . Such kind of equations are relevant, for instance, in connection with homogenization problems, see [8]. When the Hamiltonian is quasiconvex, a wide qualitative analysis of the critical equation has been performed in [7] looking at the properties of the related intrinsic metric.

In this respect a crucial role is played by the so-called Aubry set \mathcal{A} whose points are characterized by two simultaneous properties, namely $L(x, \cdot)$ is solution to the equation on the whole \mathbb{R}^n , and not just in $\mathbb{R}^n \setminus \{x\}$, if $x \in \mathcal{A}$, and the intrinsic metric fails to be equivalent to the Euclidean one around x .

It is a relevant open problem in the field to understand if something similar can be done for nonconvex critical Hamilton–Jacobi equations.

Our contribution is simply to point out, in the nonconvex case, through a couple of examples, Examples 6.1, 6.2, the existence of points y for which $S(y, \cdot)$ is solution to the critical equation on the whole space but no degeneration of the intrinsic metric takes place around them with respect to the Euclidean distance. Unfortunately, this seems to indicate that the metric approach is not viable for the analysis of the critical equation in the absence of convexity conditions on H .

The paper is divided into 6 sections. Section 2 is devoted to fix the notation and give some preliminaries and results on nonsmooth analysis and viscosity solutions theory. In Section 3 we introduce the basic object of our investigation, i.e. the nonsymmetric metric related to the Hamilton–Jacobi equation. In Section 4 the property of the metric are exploited to construct a solution for Dirichlet problems, while in Section 5 are established sufficient conditions on the boundary datum in order that such solution agrees with it on the boundary. Finally, in Section 6 it is given some applications to the analysis of the critical equation in the nonconvex setting.

ACKNOWLEDGEMENTS. – The first author has been partially supported by the University of Roma "La Sapienza" through the Ateneo program "Metodi di viscosità metrici e di teoria del controllo per EDP non lineari". He appreciatively acknowledges the hospitality and support of the Department of Mathematics of the University of Roma "La Sapienza", where this research was initiated.

2. PRELIMINARIES AND NOTATIONS

We consider, throughout the paper, Hamiltonians with state variables in the Euclidean n -dimensional space \mathbb{R}^n . Given $x, y \in \mathbb{R}^n$, $x = (x_1, \dots, x_n)$, $y = (y_1, \dots, y_n)$,

a subset A of \mathbb{R}^n , $r > 0$, we denote by:

$$\begin{aligned} \partial A, \bar{A}, \text{int}(A) & \quad (\text{the } \textit{topological boundary}, \text{ the } \textit{closure} \\ & \quad \text{and the } \textit{interior} \text{ of } A, \text{ respectively}) \\ \langle y, x \rangle &= \sum_{i=1}^n x_i y_i & (\text{the } \textit{Euclidean} \text{ scalar product }), \\ |y - x| &= \sqrt{\langle y - x, y - x \rangle} & (\text{the } \textit{Euclidean} \text{ distance}), \\ d(x, A) &= \inf_{z \in A} |z - x| & (\text{the } \textit{Euclidean} \text{ distance of } x \text{ from } A), \\ \pi_{\bar{A}}(x) &= \{z \in \bar{A} : d(x, A) = |x - z|\} & (\text{the } \textit{projection set} \text{ of } x \text{ on } \bar{A}), \\ d^\#(x, A) &= 2d(x, A) - d(x, \partial A) & (\text{the } \textit{signed} \text{ distance of } x \text{ from } A), \\ B(x, r) &= \{z \in \mathbb{R}^n : |z - x| < r\} & (\text{the } \textit{Euclidean} \text{ ball centered at } x \text{ of radius } r). \end{aligned}$$

Definition 2.1. Let A be a subset of \mathbb{R}^n and $a \in A$, we say that A is *star-shaped with respect to a* if for every $\lambda \in [0, 1]$, $p \in A$, $\lambda a + (1 - \lambda)p \in A$. We say that A is *strictly star-shaped with respect to a* if, in addition, $\lambda a + (1 - \lambda)p \in \text{int}(A)$ when $\lambda \in (0, 1)$.

We will denote by $\text{co } A$ the convex hull of A , namely the intersection of all convex subsets of \mathbb{R}^n containing A . The *support function* $\sigma_A(\cdot)$ is defined by:

$$\sigma_A(q) = \sup_{p \in A} \langle q, p \rangle.$$

Note that $\sigma_A(\cdot) = \sigma_{\text{co } A}(\cdot)$.

Definition 2.2. Let K be a closed subset, $p_0 \in K$, $q \in \mathbb{R}^n$, we say that q is a *proximal normal* to K at p_0 if there exists $\rho = \rho(p_0) > 0$ with

$$\langle q, p - p_0 \rangle \leq \rho |q| |p - p_0|^2 \quad \text{for every } p \in K.$$

The proximal normals to K at p_0 make up a convex (not necessarily closed) cone that will be denoted by $N_K^P(p_0)$ and called *proximal normal cone*. For a closed convex set, say C , the proximal cone reduces to the usual cone of convex analysis, given by

$$N_C(p_0) = \{q \in \mathbb{R}^n : \langle q, p - p_0 \rangle \leq 0 \text{ for all } p \in C\}.$$

We recall that it is, in addition, closed. Note that $\sigma_C(q) = \langle p_0, q \rangle$ for some $q \in \mathbb{R}^n$, $p_0 \in C$ if and only if $q \in N_C(p_0)$.

A $p_0 \in C$ is called an *extreme point* of C if $p_0 = \lambda p_1 + (1 - \lambda)p_2$ for some $0 < \lambda < 1$, $p_1, p_2 \in C$ implies $p_1 = p_2 = p_0$. We state for later use the Krein–Milman Theorem about extreme points and a corollary.

Theorem 2.1. *Every compact and convex subset C of \mathbb{R}^n is the convex hull of its extreme points. Conversely if $C = \text{co}(K)$ with K compact subset of \mathbb{R}^n , then every extreme point of C belongs to ∂K .*

See for the proof . [9, Corollary 18.5.1, p. 167] and [9, Corollary 18.3.1, p. 165].

Corollary 2.1. *Let $C \subset \mathbb{R}^n$ be a compact convex set, assume that $q \in N_C(p)$ for some $p \in C$. Then there exists an extreme point \bar{p} of C such that $q \in N_C(\bar{p})$.*

Proof. Define $F := \{p \in C : \langle q, p \rangle = \sigma_C(q)\}$ and notice that it is a compact and convex subset of C . So it has at least an extreme point, say \bar{p} , thanks to Krein–Milman Theorem. We prove that \bar{p} is also an extreme point for C .

Assume, by contradiction, that there exist $\lambda \in (0, 1)$, $p_1, p_2 \in C \setminus \{\bar{p}\}$ with $\bar{p} = \lambda p_1 + (1 - \lambda)p_2$. Therefore at least one of the p_i , $i = 1, 2$, is not in F since \bar{p} is an extreme point of F , and so, for such an i , $\langle q, p_i \rangle < \sigma_C(q)$. From this we find

$$\sigma_C(q) = \langle q, \bar{p} \rangle = \lambda \langle q, p_1 \rangle + (1 - \lambda) \langle q, p_2 \rangle < \sigma_C(q),$$

which is impossible. □

For these and other properties of convex sets, that will be used in what follows, we refer to [9]. We proceed by giving some notions of generalized differentials.

Definition 2.3. For a continuous function u from \mathbb{R}^n to \mathbb{R} , we define:

$$D^+u(x) = \left\{ p : \limsup_{|v| \rightarrow 0} \frac{u(x+v) - u(x) - \langle p, v \rangle}{|v|} \leq 0 \right\},$$

$$D^-u(x) = \left\{ p : \liminf_{|v| \rightarrow 0} \frac{u(x+v) - u(x) - \langle p, v \rangle}{|v|} \geq 0 \right\},$$

they are called the (Fréchet or viscosity) *superdifferential* and *subdifferential* of u at x , respectively. These sets are closed and convex, possibly empty.

A characterization of these objects can be given as follows: $v \in D^+u(x)$ (resp. $v \in D^-u(x)$) iff there exists a neighborhood V of x and a C^1 function $\varphi : V \rightarrow \mathbb{R}$ such that $u - \varphi$ attains its maximum (resp. minimum) in V at x and $v = D\varphi(x)$. Such φ will be called a super (resp. sub)tangent test function. We say that φ is a strict super (resp. sub)tangent if, in addition, x is strict local maximizer (resp. minimizer) of $u - \varphi$.

Definition 2.4. Given a locally Lipschitz–continuous function u defined in \mathbb{R}^n , and denoted by $\text{dom}(Du)$ its differentiability set (which is of full measure by Rademacher’s theorem) the *Clarke’s generalized gradient* of u at x is the compact convex set:

$$\partial u(x) := \text{co} \left\{ v \in \mathbb{R}^n : \exists \{x_n\}_{n \in \mathbb{N}} \subset \text{dom}(Du) \text{ with } v = \lim_{n \rightarrow \infty} Du(x_n) \right\}.$$

We proceed by giving some notions from viscosity solutions theory. A detailed account of this topic, with some applications, is given in [1]. We are interested in the Hamilton–Jacobi equation

$$(1) \quad H(x, Du) = 0, \quad x \in \mathbb{R}^n$$

in the unknown u . The Hamiltonian H is supposed to be continuous in both arguments

Definition 2.5. A continuous function u from \mathbb{R}^n to \mathbb{R} is called a *viscosity subsolution* of (1) if

$$H(x, p) \leq 0 \quad \text{for any } x, p \in D^+u(x).$$

A *viscosity supersolution* is defined by replacing in the above formula D^+ by D^- and requiring $H(x, p) \geq 0$. A *viscosity solution* is a function which enjoys the property of being a sub and a supersolution at the same time.

From now on the term (sub, super) solution must be understood in the previous viscosity sense. A subsolution of equation (1) is called *strict* in some open subset Ω if

$$H(x, p) \leq -\delta \quad \text{for any } x \in \Omega, p \in D^+u(x), \text{ and for some } \delta > 0.$$

We say that 0 is the *critical value* of H or that (1) is a critical equation if the equation $H = -\delta$ does not have subsolutions for any δ positive.

Definition 2.6. Let $T > 0$ be fixed and $B_1, B_2 \subseteq B^T := L^\infty((0, T), \mathbb{R}^n)$. A nonanticipating strategy is a map $\gamma : B_1 \rightarrow B_2$ such that if $t \in (0, T)$ and $\eta_1, \eta_2 \in B_1$ are such that $\eta_1 = \eta_2$ a.e. in $(0, t)$, then $\gamma[\eta_1] = \gamma[\eta_2]$ a.e. in $(0, t)$.

For every x, y , we define

$$B_{x,y}^T := \left\{ \zeta \in B^T : x + \int_0^T \zeta(t) dt = y \right\},$$

and denote by $\Gamma^T, \Gamma_{x,y}^T$ the nonanticipating strategies from B^T to B^T and from B^T to $B_{x,y}^T$, respectively. In the case where $T = 1$, we write $B, B_{x,y}, \Gamma, \Gamma_{x,y}$ instead of $B^1, B_{x,y}^1, \Gamma^1, \Gamma_{x,y}^1$.

3. METRICS ASSOCIATED WITH HAMILTON–JACOBI EQUATIONS

Throughout the paper, we consider the equation (1) under the following assumptions:

- (H1) H is continuous in both arguments,
- (H2) $H(x, 0) \leq 0$ for any x ,
- (H3) if $H(x, 0) = 0$ then $\text{int}(Z(x)) = \emptyset$, where $Z(x) := \{p \in \mathbb{R}^n : H(x, p) \leq 0\}$
- (H4) $\lim_{|p| \rightarrow +\infty} H(x, p) = +\infty$ locally uniformly in x ,
- (H5) if $\text{int}(Z(x)) \neq \emptyset$ then $\partial\{p \in \mathbb{R}^n : H(x, p) < 0\} = \{p \in \mathbb{R}^n : H(x, p) = 0\}$.

We set

$$(2) \quad \mathcal{E} = \{x : \text{int}Z(x) = \emptyset\}.$$

Note that if \mathcal{E} is nonempty then the equation (1) is critical. The Hamiltonians to which our setting applies include those of separated–variables form $F(p) - f(x)$, where the potential f is nonnegative and F has minimum 0 with minimizers making up a set with empty interior containing 0. In this case the corresponding equation is critical if and only $\min f = 0$, and then \mathcal{E} is the set of minimizers of f . We will write Z , instead of $Z(x)$, in the case where the Hamiltonian is independent of x . The coercivity condition (H4) implies that the sublevels $Z(x)$ are compact for any x and that all subsolutions to (1) are locally Lipschitz–continuous. The map $x \rightarrow Z(x)$ is upper semicontinuous in the Hausdorff metric, and continuous at any x where $\text{int}(Z(x)) \neq \emptyset$, see [10, Proposition 2.1].

Remark 3.1. Conversely, an Hamiltonian satisfying our assumptions can be constructed starting from any Hausdorff–continuous set valued function $x \mapsto Z(x)$, satisfying

$$\begin{aligned} 0 &\in Z(x) \quad \text{for any } x, \\ \text{int}Z(x) &= \emptyset \quad \text{whenever } 0 \in \partial Z(x), \end{aligned}$$

by setting $H(x, p) = d^\#(p, Z(x))$.

Next we recall the definition of intrinsic distance associated with the equation (1), see [10]. This generalizes the relationship between Euclidean metric and the classical Eikonal equation $|Du| = 1$. The nonconvex character of the Hamiltonian leads to more involved formulae. Let $T > 0$, $\eta \in B^T$, $\gamma \in \Gamma^T$, $z \in \mathbb{R}^n$. We set

$$\mathcal{I}_z^T(\eta, \gamma) := \int_0^T -\langle \gamma[\eta](t), \eta(t) \rangle - |\gamma[\eta](t)| d^\sharp(\eta, Z(\xi_z^{\eta, \gamma}(t))) dt$$

where

$$\xi_z^{\eta, \gamma}(t) := z + \int_0^t \gamma[\eta](s) ds$$

is the integral curve of $\gamma[\eta]$ starting from z . The superscript T will be omitted if equal to 1.

Definition 3.1. For each pair of points x, y , we define the intrinsic metric as

$$S(y, x) = \inf_{\gamma \in \Gamma_{x,y}} \sup_{\eta \in B} \mathcal{I}_x(\eta, \gamma).$$

The next proposition summarizes the main properties of S .

Proposition 3.1. *Let $x, y, z \in \mathbb{R}^n$, $T > 0$. The following properties hold:*

- i. $S(y, x) = \inf_{\gamma \in \Gamma^T} \sup_{\eta \in B^T} \{\mathcal{I}_x^T(\eta, \gamma) + S(y, \xi_x^{\eta, \gamma}(T))\}$.
- ii. $S(y, x) \geq 0$ and $S(x, x) = 0$, if, in addition, $\mathcal{E} = \emptyset$ then $S(y, x) > 0$ whenever $x \neq y$,
- iii. $S(y, x) \leq S(y, z) + S(z, x)$,
- iv. If $\mathcal{E} = \emptyset$ then S is a metric locally equivalent to the Euclidean one,
- v. For every subset compact K , there exists $C_K > 0$ such that $S(y_0, x_0) \leq C_K |y_0 - x_0|$ for all $x_0, y_0 \in K$.

Proof. i. See [10, Proposition 3.3].

- ii. According to (H2), $0 \in Z(z)$ for all z , therefore for $\bar{\eta}(s) \equiv 0$ we have

$$S(y, x) \geq \inf_{\gamma \in \Gamma_{x,y}} \mathcal{I}_x(\bar{\eta}, \gamma) = \inf_{\gamma \in \Gamma_{x,y}} \int_0^1 -|\gamma[\bar{\eta}](t)| d^\sharp(\bar{\eta}, Z(\xi_x^{\bar{\eta}, \gamma}(t))) dt \geq 0.$$

In order to obtain the converse inequality when $x = y$, define the strategy $\bar{\gamma} : B \rightarrow B_{x,x}$ by setting $\bar{\gamma}[\eta](t) \equiv 0$, then

$$S(x, x) \leq \sup_{\eta \in B_{x,x}} \mathcal{I}_x(\eta, \bar{\gamma}) = 0.$$

Finally, let x, y be two different points, we set $\bar{\eta} \equiv 0$ in $[0, 1]$. Since $\gamma[\bar{\eta}](t) \neq 0$ for t in a subset of $[0, 1]$ with positive 1-dimensional Lebesgue measure, for any $\gamma \in \Gamma_{x,y}$, and $d^\sharp(0, Z(z)) < 0$ for any z , we have

$$S(y, x) \geq \inf_{\gamma \in \Gamma_{x,y}} \int_0^1 -|\gamma[\bar{\eta}](t)| d^\sharp(\bar{\eta}, Z(\xi_x^{\bar{\eta}, \gamma}(t))) dt > 0$$

- iii. According to items i. ii.

$$\begin{aligned} S(y, x) &= \inf_{\gamma \in \Gamma} \sup_{\eta \in B} \{\mathcal{I}_x^T(\eta, \gamma) + S(y, \xi_x^{\eta, \gamma}(T))\} \leq \inf_{\gamma \in \Gamma_{x,z}} \sup_{\eta \in B} \{\mathcal{I}_x^T(\eta, \gamma) + S(y, z)\} \\ &= S(y, z) + S(z, x) \end{aligned}$$

iv. and v. Define $R = \sup\{|p| : p \in Z(x), x \in \text{co} K\}$. We assume $y_0 \neq x_0$, otherwise there is nothing to prove. We define a nonanticipating strategy $\bar{\gamma} \in \Gamma_{x_0, y_0}$ by setting $\bar{\gamma}[\eta] \equiv y_0 - x_0$, so that $\xi_{x_0}^{\eta, \bar{\gamma}}(t) = x_0 + t(y_0 - x_0) \in \text{co} K$, $t \in [0, 1]$. We have

$$\begin{aligned} \frac{S(y_0, x_0)}{|y_0 - x_0|} &\leq \sup_{\eta \in B} \int_0^1 -\left\langle \frac{y_0 - x_0}{|y_0 - x_0|}, \eta \right\rangle - d^\sharp(\eta, Z(\xi_{x_0}^{\eta, \bar{\gamma}}(t))) dt \\ &= \sup_{\eta \in B} \left\{ \int_{I^+} -\left\langle \frac{y_0 - x_0}{|y_0 - x_0|}, \eta \right\rangle - d^\sharp(\eta, Z(\xi_{x_0}^{\eta, \bar{\gamma}}(t))) dt + \right. \\ &\quad \left. + \int_{I^-} -\left\langle \frac{y_0 - x_0}{|y_0 - x_0|}, \eta \right\rangle - d^\sharp(\eta, Z(\xi_{x_0}^{\eta, \bar{\gamma}}(t))) dt \right\}, \end{aligned}$$

where $I^+ = \{t \in [0, 1] : |\eta(t)| > R\}$ and $I^- = [0, 1] \setminus I^+$. For $t \in I^-$

$$-\left\langle \frac{y_0 - x_0}{|y_0 - x_0|}, \eta(t) \right\rangle - d^\sharp(\eta(t), Z(\xi_{x_0}^{\eta, \bar{\gamma}}(t))) \leq R + R = 2R.$$

For $t \in I^+$, we have by (H2)

$$-\left\langle \frac{y_0 - x_0}{|y_0 - x_0|}, \eta(t) \right\rangle - d^\sharp(\eta(t), Z(\xi_{x_0}^{\eta, \bar{\gamma}}(t))) \leq |\eta(t)| - d^\sharp(\eta(t), B(0, R)) = |\eta(t)| - |\eta(t)| + R = R.$$

Hence, summing up, we find $S(y_0, x_0) \leq 2R|y_0 - x_0|$, as desired. \square

The item v. of the previous result together with the triangle inequality clearly implies that for any fixed y_0 the function $x \mapsto S(y_0, x)$ is locally Lipschitz-continuous. Such functions make up a class of fundamental subsolutions of the problem $H(x, Du) = 0$, as made precise in the next proposition.

Proposition 3.2. *Let x_0 be fixed. Then $v(x) := S(x_0, x)$ is a subsolution of (1) in the whole space and a supersolution of (1) in the whole space except x_0 .*

Proof. See [10, Theorem 4.1, Theorem 4.2]. \square

It can be showed, see [10], that S is not, in general, a path metric in the sense that the distance between two given points can be strictly less than the infimum of the corresponding length of curves joining them. As already pointed out in the Introduction, this is, in a sense, the metric counterpart of the lack of the convexity of the Hamiltonian. Another nonsymmetric distance, related to the convex-valued function $x \mapsto \text{co}Z(x)$ can be defined as follows:

Definition 3.2. Given x, y , we set

$$L(x, y) = \inf \left\{ \int_0^1 \sigma_{Z(\xi(t))}(\dot{\xi}(t)) dt : \xi \text{ Lipschitz-continuous curve defined in } [0, 1] \right. \\ \left. \text{joining } x \text{ to } y \right\}.$$

Since the support function of a set and of its convex hull coincide, the metric L can be analogously defined replacing in the previous formula $\sigma_{Z(\xi(t))}$ by $\sigma_{\text{co}Z(\xi(t))}$.

L is a path metric, more precisely of Finsler type, locally equivalent to the Euclidean metric (cfr. [10, Section §1]) in the case where $\mathcal{E} = \emptyset$. In general $S(y, x) \leq L(y, x)$, and $S = L$ if the 0-sublevels of H are convex (cfr. [10, Theorem

2.1]). Another case where the two metrics coincide is illustrated in the following result.

Proposition 3.3. *Assume that the set-valued map $\text{co}Z(\cdot)$ is constant, then $S = L$.*

Proof. We denote by K the constant value assumed by $\text{co}Z(\cdot)$, which is clearly a convex compact set. We have $L(y_0, x_0) = \sigma_K(x_0 - y_0)$ for any x_0, y_0 , which, in turn, implies $L(y_0, x_0) = \langle p_0, x_0 - y_0 \rangle$, for some $p_0 \in K$ depending on x_0 and y_0 . We moreover know from Corollary 2.1 that p_0 can be chosen as an extreme point of K , so that $p_0 \in \partial Z(x)$ for any x by Theorem 2.1. We proceed by giving an estimate from below of $S(y_0, x_0)$; for $\bar{\eta} \equiv p_0$ we get

$$S(y_0, x_0) \geq \inf_{\gamma \in \Gamma_{x_0, y_0}} \int_0^1 -\langle p_0, \gamma[\bar{\eta}] \rangle dt = \langle p_0, x_0 - y_0 \rangle = L(y_0, x_0).$$

This concludes the proof, being the converse inequality always true, as already pointed out. \square

Even if $L = S$ one cannot expect that representation formulae for solutions to (1), based on the intrinsic distance, can be extended without variations from the convex to the nonconvex case. We end the section by discussing an example of this setup. We first recall

Proposition 3.4. *Assume $p \mapsto H(x, p)$ to be convex. Let K be a compact set and g a continuous datum on K satisfying $g(y_1) - g(y_2) \leq L(y_2, y_1)$ for any y_1, y_2 in K , then*

$$(3) \quad \min_{y \in K} L(y, x) + g(y)$$

is a solution of (1) in $\mathbb{R}^n \setminus K$ taking the value g on K .

As announced, we exhibit in the next example a nonconvex Hamiltonian, independent of x , for which L and S coincide according to Proposition 3.3, but formula (3), with $g \equiv 0$, does not give a solution of (1).

Example 3.1. The ground space is \mathbb{R}^2 , $K = \partial B((0, 0), 1)$. We take $Z = \overline{B((0, 0), 1)} \setminus B((2, 0), \sqrt{3})$, $H = H(p) = \inf\{\lambda > 0 : p/\lambda \in Z\}$, so that Z is the 1-sublevel of H , and consider the equation $H(p) = 1$. Note that the boundaries of the two balls defining Z intersect in the two points $p_0 = (\frac{1}{2}, \frac{\sqrt{3}}{2})$ and $p_1 = (\frac{1}{2}, -\frac{\sqrt{3}}{2})$. This justifies the choice of the radius of the large ball. Accordingly

$$\text{co}Z = \overline{B((0, 0), 1)} \cap \{(x_1, x_2) : x_1 \leq 1/2\}.$$

Since H does not depend on x , $S(x, y) = L(x, y) = \sigma_Z(y - x) = \sigma_{\text{co}Z}(y - x)$. We recall that, given any unit vector y , the relation

$$(4) \quad \sigma_Z(y) = \sigma_{\text{co}Z}(y) = \langle p, y \rangle,$$

for some $p \in Z$, is equivalent to $p \in \text{co}Z$ and $y \in N_{\text{co}Z}(p)$. Therefore such a p is equal to y if $y \in K \cap Z$, if instead $y \in K \setminus Z$, then a p satisfying (4) is given either by $\bar{x} := (1/2, \sqrt{3}/2)$ or by $\underline{x} := (1/2, -\sqrt{3}/2)$. If y is an unit vector belonging to $K \setminus Z$, we get in polar coordinates $y = (\cos \theta, \sin \theta)$ with $|\theta| < \frac{\pi}{3}$ and

$$\sigma_Z(y) = \max\{\langle \bar{x}, y \rangle, \langle \underline{x}, y \rangle\} = \cos\left(\frac{\pi}{3} - |\theta|\right) \geq \frac{1}{2}.$$

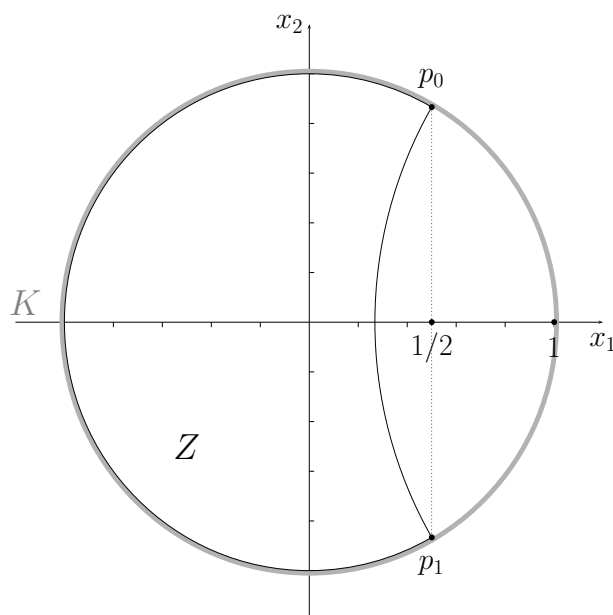
FIGURE 1. K and $Z(x)$

Altogether we find that $\sigma_Z(y) \geq \frac{1}{2}$ for every $y \in K$, in addition the infimum of $\sigma_Z(\cdot)$ in K is attained at $y = (1, 0)$ and equals $1/2$. In other terms $\min_{y \in K} L(y, 0) = \frac{1}{2}$. We proceed showing that $L(K, \cdot) := \min_{y \in K} L(y, \cdot)$ is not a solution of $H(Du) = 1$ in $\mathbb{R}^2 \setminus K$, to repeat: formula (3), with $g \equiv 0$, does not provide a solution of $H(Du) = 1$. Set

$$\psi(x) = \frac{1}{2} \left(x_1 + \sqrt{1 - x_2^2} \right) \quad \text{for } x \in B((0, 0), 1),$$

note that if $\psi(x) > 0$ then

$$\sigma_Z((2\psi(x), 0)) = \psi(x),$$

and consequently

$$\psi(x) = L(x - 2(\psi(x), 0), x),$$

which implies $\psi(x) \geq L(K, x)$ since $x - 2(\psi(x), 0) \in K$. Taking into account that $\psi(x)$ is strictly positive in some neighborhood of $(0, 0)$ and $\psi(0, 0) = \frac{1}{2}$, we discover, in the end, that ψ is supertangent to $L(K, \cdot)$ at $x = (0, 0)$. However $D\psi(0, 0) = (1/2, 0)$ does not belong to Z . Actually it is in $\text{co } Z$.

4. THE DIRICHLET PROBLEM IN THE NONCONVEX CASE

In this section we aim to solve the Dirichlet problem

$$(5) \quad \begin{cases} H(x, Du(x)) = 0 & \text{for } x \in \mathbb{R}^n \setminus K \\ u(x) = g(x) & \text{for } x \in K \end{cases}$$

where K is a compact subset of \mathbb{R}^n and g a continuous datum on K . A particular case is

$$(6) \quad \begin{cases} H(x, Du(x)) = 0 & \text{for } x \in \Omega \\ u(x) = g(x) & \text{for } x \in \partial\Omega \end{cases}$$

where Ω is an open bounded domain of \mathbb{R}^n . We look for solutions attaining continuously the datum on K and $\partial\Omega$, respectively. The issue at stake is to provide a generalization of formula (3) which does not hold in the nonconvex setting, even if $S = L$, as seen in Example 3.1.

In order to give representation formulae for solutions to (5) we define some new families of strategies and velocities where K is involved.

Definition 4.1. We define

$$\begin{aligned} B_{x,K}^T &:= \left\{ \zeta \in L^\infty([0, T], \mathbb{R}^n) : x + \int_0^T \zeta(s) ds \in K \right\} \\ \Gamma_{x,K}^T &:= \left\{ \gamma : B^T \rightarrow B_{x,K}^T : \gamma \text{ is a nonanticipating strategy} \right\}, \end{aligned}$$

as usual the subscript T will be omitted whenever $T = 1$.

We set

$$(7) \quad w(x) = \inf_{\gamma \in \Gamma_{x,K}} \sup_{\eta \in B} \{ \mathcal{I}_x(\eta, \gamma) + g(\xi_x^{\eta, \gamma}(1)) \}$$

$$(8) \quad w_0(x) = \inf_{y \in K} \{ g(y) + S(y, x) \},$$

for $x \in \mathbb{R}^n$, and proceed by establishing some comparison results for w , w_0 and g .

Proposition 4.1. *Let w and w_0 defined as in 4.1, then for every $x, y \in \mathbb{R}^n$ one has*

- i. $w(x) \leq w_0(x)$;
- ii. $w(x) - w(y) \leq S(y, x)$ and so w is locally Lipschitz-continuous;
- iii. $w_0(x) - w_0(y) \leq S(y, x)$ and so w_0 is locally Lipschitz-continuous;
- iv. $w_0 \leq g$ on K .

Proof. i. By the continuity of g and S , there exists $y_0 \in K$ such that

$$w_0(x) = S(y_0, x) + g(y_0) = \inf_{\gamma \in \Gamma_{x,y_0}} \sup_{\eta \in B} \{ \mathcal{I}_x(\eta, \gamma) + g(y_0) \} \geq w(x).$$

- ii. Given $\varepsilon > 0$, choose a ε -almost optimal strategy $\bar{\gamma} \in \Gamma_{x,y}^{1/2}$, i.e.

$$S(y, x) > \sup_{\eta \in B^{1/2}} \mathcal{I}_x^{1/2}(\eta, \bar{\gamma}) - \varepsilon,$$

then define

$$\tilde{\Gamma} := \{ \gamma \in \Gamma_{x,K} : \gamma[\eta](s) = \bar{\gamma}[\eta](s) \text{ for all } \eta \in B, s \in [0, 1/2] \}$$

We have

$$\begin{aligned} w(x) &\leq \inf_{\gamma \in \tilde{\Gamma}} \sup_{\eta \in B} \{ \mathcal{I}_x(\eta, \gamma) + g(\xi_x^{\eta, \gamma}(1)) \} \\ &= \sup_{\eta \in B^{1/2}} \mathcal{I}_x^{1/2}(\eta, \bar{\gamma}) + \inf_{\gamma \in \Gamma_{y,K}^{1/2}} \sup_{B^{1/2}} \{ \mathcal{I}_y^{1/2}(\eta, \gamma) + g(\xi_x^{\eta, \bar{\gamma}}(1/2)) \} \\ &\leq S(y, x) + \varepsilon + w(y), \end{aligned}$$

which implies the result. Notice that we have exploited the invariance properties of S under change of time parametrization.

iii. There exists $y_0 \in K$ such that

$$w_0(x) - w_0(y) \leq S(y_0, x) + g(y_0) - S(y_0, x) - g(y_0) \leq S(y, x).$$

v. Set $\bar{\gamma}$ to be the null strategy, i.e. $\bar{\gamma}[\eta] \equiv 0$ for all $\eta \in B$. Then for all $x \in K$

$$w(x) \leq \sup_{\eta \in B} \mathcal{I}_x(\eta, \bar{\gamma}) + g(x) = g(x).$$

□

As done before for S , we state a dynamic programming principle for the function w .

Proposition 4.2. *For all $x \in \mathbb{R}^n$, $0 < t < 1$ it holds*

$$w(x) = \inf_{\alpha \in \Gamma^t} \sup_{\eta \in B^t} \{ \mathcal{I}_x^t(\eta, \alpha) + w(\xi_x^{\eta, \alpha}(t)) \},$$

where $\xi_x^{\eta, \alpha}(s) = x + \int_0^s \alpha[\eta] ds$.

Proof. Fix $t \in (0, 1)$ and set

$$A := \inf_{\alpha \in \Gamma^t} \sup_{\eta \in B^t} \{ \mathcal{I}_x^t(\eta, \alpha) + w(\xi_x^{\eta, \alpha}(t)) \}.$$

By the invariance of w by time parametrization and the fact that $g(y) \geq w(y)$ if $y \in K$ we have

$$\begin{aligned} w(x) &= \inf_{\gamma \in \Gamma_{x,K}^t} \sup_{\eta \in B^t} \{ \mathcal{I}_x^t(\eta, \gamma) + g(\xi_x^{\eta, \gamma}(t)) \} \geq \inf_{\gamma \in \Gamma_{x,K}^t} \sup_{\eta \in B^t} \{ \mathcal{I}_x^t(\eta, \gamma) + w(\xi_x^{\eta, \gamma}(t)) \} \\ &\geq \inf_{\gamma \in \Gamma^t} \sup_{\eta \in B^t} \{ \mathcal{I}_x^t(\eta, \gamma) + w(\xi_x^{\eta, \gamma}(t)) \} = A. \end{aligned}$$

It is left to prove $w(x) \leq A$. For any given $z \in K$, denote by γ_z a nonanticipating strategy

$$\gamma_z : B^{1-t} \rightarrow B_{z,K}^{1-t}$$

such that

$$w(z) \geq \sup_{\eta \in B^{1-t}} \{ \mathcal{I}_z^{1-t}(\eta, \gamma_z) + g(\xi_z^{\eta, \gamma_z}(1-t)) \} - \varepsilon.$$

Let $\bar{\alpha} : B^t \rightarrow B^t$ be a nonanticipating strategy with

$$A \geq \sup_{\eta \in B^t} \{ \mathcal{I}_x^t(\eta, \bar{\alpha}) + w(\xi_x^{\eta, \bar{\alpha}}(t)) \} - \varepsilon.$$

Set $z_\eta^t = \xi_x^{\eta, \bar{\alpha}}(t)$, we have

$$A \geq \sup_{\eta \in B^t} \left\{ \mathcal{I}_x^t(\eta, \bar{\alpha}) + \sup_{\rho \in B^{1-t}} \left\{ \mathcal{I}_{z_\eta^t}^{1-t}(\rho, \gamma_{z_\eta^t}) + g\left(\xi_{z_\eta^t}^{\rho, \gamma_{z_\eta^t}}(1-t)\right) \right\} \right\} - 2\varepsilon.$$

We define a nonanticipating strategy $\delta : B \rightarrow B$ as follows

$$\delta[\eta](s) := \begin{cases} \bar{\alpha}[\eta]_{[0,t]}(s) & \text{for } s \in [0, t] \\ \gamma_{z_\eta^t}[\tilde{\eta}](s-t) & \text{for } s \in [t, 1] \end{cases},$$

where $\tilde{\eta} \in B^{1-t}$ is defined by $\tilde{\eta}(s) = \eta(t+s)$ for any $s \in [0, 1-t]$.

Claim 1. $\delta[\eta] \in B_{x,K}$ for all $\eta \in B$.

In fact, we have

$$\begin{aligned} x + \int_0^1 \delta[\eta](s) ds &= x + \int_0^t \bar{\alpha}[\eta]_{|[0,t]} ds + \int_t^1 \gamma_{z_\eta^t}[\tilde{\eta}](s-t) ds \\ &= z_\eta^t + \int_0^{1-t} \gamma_{z_\eta^t}[\tilde{\eta}](\sigma) d\sigma = \xi_{z_\eta^t}^{\tilde{\eta}, \gamma_{z_\eta^t}}(1-t) \in K \end{aligned}$$

This ends the proof of Claim 1.

Define the following quantities

$$\begin{aligned} A_1 &:= \sup_{\eta \in B^t} \left\{ \mathcal{I}_x^t(\eta, \bar{\alpha}) + \sup_{\rho \in B^{1-t}} \left\{ \mathcal{I}_{z_\eta^t}^{1-t}(\rho, \gamma_{z_\eta^t}) + g\left(\xi_{z_\eta^t}^{\rho, \gamma_{z_\eta^t}}(1-t)\right) \right\} \right\}, \\ A_2 &:= \sup_{\eta \in B} \left\{ \mathcal{I}_x(\eta, \delta) + g(\xi_x^{\eta, \delta}(1)) \right\}. \end{aligned}$$

Claim 2. $A_1 = A_2$.

In fact, we have that for every $\varepsilon > 0$ there exist $\tau_0 \in B^t, \rho_0 \in B^{1-t}$ such that

$$\begin{aligned} A_1 &\leq \mathcal{I}_x^t(\tau_0, \bar{\alpha}) + \sup_{\rho \in B^{1-t}} \left\{ \mathcal{I}_{z_{\tau_0}^t}^{1-t}(\rho, \gamma_{z_{\tau_0}^t}) + g\left(\xi_{z_{\tau_0}^t}^{\rho, \gamma_{z_{\tau_0}^t}}(1-t)\right) \right\} + \varepsilon \\ &\leq \mathcal{I}_x^t(\tau_0, \bar{\alpha}) + \mathcal{I}_{z_{\tau_0}^t}^{1-t}(\rho_0, \gamma_{z_{\tau_0}^t}) + g\left(\xi_{z_{\tau_0}^t}^{\rho_0, \gamma_{z_{\tau_0}^t}}(1-t)\right) + 2\varepsilon \\ &= \mathcal{I}_x(\bar{\tau}, \delta) + g(\xi_x^{\bar{\tau}, \delta}(1)) + 2\varepsilon \leq A_2 + 2\varepsilon \end{aligned}$$

where $\bar{\tau} \in B$ is defined by juxtaposition of τ_0 and ρ_0 , namely $\bar{\tau}(s) = \tau_0(s)$ for $s \in [0, t]$ and $\bar{\tau}(s) = \rho_0(s-t)$ if $s \in]t, 1]$.

On the other hand there exists $\eta_0 \in B$ such that

$$A_2 \leq \mathcal{I}_x(\eta_0, \delta) + g(\xi_x^{\eta_0, \delta}(1)) + \varepsilon.$$

Denoting by $\eta_1 = \eta_0|_{[0,t]}$, $\eta_2 = \eta_0|_{]t,1]}$ and $\tilde{\eta}_2(s) = \eta_2(t+s)$ for $s \in [0, 1-t]$, we have

$$\begin{aligned} A_2 &\leq \mathcal{I}_x(\eta_1, \bar{\alpha}) + \mathcal{I}_{z_{\eta_1}^t}^{1-t}(\tilde{\eta}_2, \gamma_{z_{\eta_1}^t}) + g\left(\xi_{z_{\eta_1}^t}^{\tilde{\eta}_2, \gamma_{z_{\eta_1}^t}}(1-t)\right) + \varepsilon \\ &\leq \sup_{\eta \in B^t} \left\{ \mathcal{I}_x(\eta, \bar{\alpha}) + \mathcal{I}_{z_\eta^t}^{1-t}(\tilde{\eta}_2, \gamma_{z_\eta^t}) + g\left(\xi_{z_\eta^t}^{\tilde{\eta}_2, \gamma_{z_\eta^t}}(1-t)\right) \right\} + \varepsilon \\ &\leq A_1 + \varepsilon. \end{aligned}$$

By letting $\varepsilon \rightarrow 0$ Claim 2 is proved.

To conclude the proof of the proposition, observe that by Claim 1 and Claim 2 we have

$$A \geq A_1 - 2\varepsilon = A_2 - 2\varepsilon \geq \inf_{\gamma \in \Gamma_{x,K}} \sup_{\eta \in B} \left\{ \mathcal{I}_x(\eta, \gamma) + g(\xi_x^{\eta, \gamma}(1)) \right\} - 2\varepsilon = w(x) - 2\varepsilon.$$

□

The main interest in the function w is given by the following result:

Theorem 4.1. *The function w is a viscosity solution of (1) in $\mathbb{R}^n \setminus K$ and subsolution on the whole \mathbb{R}^n .*

The proof is broken into two parts.

Proposition 4.3. *w is a subsolution of (1) in \mathbb{R}^n .*

Proof. The proof follows the same line of [10, Theorem 4.1]. We argue by contradiction, assuming that there exists a C^1 supertangent ψ to w at $x_0 \in \mathbb{R}^n$ such that $H(x_0, D\psi(x_0)) > 0$, we can also assume without losing generality that w and ψ coincide at x_0 .

Let q_0 be a fixed unit vector. Define a map $f : \mathbb{R}^n \rightarrow \mathbb{R}^n$ by

$$f(p) := \begin{cases} \frac{p - D\psi(x_0)}{|p - D\psi(x_0)|} & \text{if } p \neq D\psi(x_0) \\ q_0 & \text{for } p = D\psi(x_0) \end{cases}.$$

Taking into account the continuity of $D\psi$ and $d^\sharp(\cdot, Z(\cdot))$, we can find positive constants θ and T_0 with $d^\sharp(D\psi(x), Z(x)) > \theta$ for $x \in B(x_0, T_0)$. Set

$$\begin{aligned} R &:= \sup\{|p| : x \in B(x_0, T_0), p \in Z(x)\}, \\ M &:= \sup\{|D\psi(x)| : x \in B(x_0, T_0)\}, \\ \varepsilon &:= \min\left\{\frac{\theta}{2(M + \theta + R)}, \frac{1}{2}\right\} \end{aligned}$$

We can select $T \in]0, T_0]$ such that

$$w(x) \leq \psi(x), \quad |D\psi(x) - D\psi(y)| < \frac{\theta\varepsilon}{8}$$

for all $x, y \in B(x_0, T)$. For every $\eta \in B^T$ and $t \in [0, T]$, we define

$$\xi_\eta(t) = x_0 + \int_0^t f(\eta(s)) ds.$$

Since $|f| = 1$, $|\xi_\eta(t) - x_0| \leq t$ for all $t \in [0, T]$.

Claim. For any $x \in B(x_0, T)$ and $p \in \mathbb{R}^n$ we have

$$(9) \quad d^\sharp(p, Z(x)) + \langle f(p), p - D\psi(x) \rangle \geq \frac{\theta}{2}.$$

Proof of the Claim. First assume $|p - D\psi(x)| \leq \theta/4$. This implies, by the very definition of θ , that $d^\sharp(p, Z) > 0$, consequently for every $p' \in \pi_Z(p)$, we find

$$d^\sharp(p, Z) = |p - p'| \geq |p' - D\psi(x)| - |p - D\psi(x)| \geq \frac{3}{4}\theta,$$

hence

$$d^\sharp(p, Z) + \langle f(p), p - D\psi(x) \rangle \geq d^\sharp(p, Z) - |p - D\psi(x)| \geq \frac{\theta}{2}.$$

Assume now that $|p - D\psi(x)| > \theta/4$. Then, according to the choice of T and the definition of $\varepsilon \leq 1/2$, we have

$$|p - D\psi(x_0)| \geq |p - D\psi(x)| - |D\psi(x) - D\psi(x_0)| > \frac{\theta}{8}.$$

So

$$\begin{aligned}
 \left| \frac{p - D\psi(x)}{|p - D\psi(x)|} - \frac{p - D\psi(x_0)}{|p - D\psi(x_0)|} \right| &= \frac{8}{\theta} \left| \frac{\theta}{8} \frac{p - D\psi(x)}{|p - D\psi(x)|} - \frac{\theta}{8} \frac{p - D\psi(x_0)}{|p - D\psi(x_0)|} \right| \\
 &= \frac{8}{\theta} |\pi_{B(0, \theta/8)}(p - D\psi(x)) - \pi_{B(0, \theta/8)}(p - D\psi(x_0))| \\
 &\leq \frac{8}{\theta} |(p - D\psi(x)) - (p - D\psi(x_0))| \\
 &\leq \frac{8}{\theta} |D\psi(x) - D\psi(x_0)| \leq \varepsilon
 \end{aligned}$$

Since $\varepsilon < 1$, we have $\langle f(p), p - D\psi(x) \rangle > 0$. We consider two further cases:

i. if $|p - D\psi(x)| > \theta/4$ and $|p| > R + \theta$, we have

$$d^\sharp(p, Z(x)) + \langle f(p), p - D\psi(x) \rangle > d^\sharp(p, Z(x)) > \theta.$$

ii. if $|p - D\psi(x)| > \theta/4$ and $|p| \leq R + \theta$ we have

$$\begin{aligned}
 \theta &\leq d^\sharp(D\psi(x), Z(x)) \leq d^\sharp(p, Z(x)) + |p - D\psi(x)| \\
 &\leq d^\sharp(p, Z(x)) + \left| \frac{p - D\psi(x)}{|p - D\psi(x)|} - \frac{p - D\psi(x_0)}{|p - D\psi(x_0)|} \right| |p - D\psi(x)| + \\
 &\quad + \langle f(p), p - D\psi(x) \rangle \\
 &\leq d^\sharp(p, Z(x)) + \varepsilon(R + \theta + M) + \langle f(p), p - D\psi(x) \rangle \\
 &\leq d^\sharp(p, Z(x)) + \frac{\theta}{2} + \langle f(p), p - D\psi(x) \rangle.
 \end{aligned}$$

This fact concludes the proof of the Claim.

We define a nonanticipating strategy $\bar{\gamma} \in \Gamma^T$ by setting $\bar{\gamma}[\eta](t) = f(\eta(t))$ for a.e. $t \in [0, T]$. According to the choice of T , we have that $\bar{\gamma} : B^T \rightarrow B^T$, and $w(\xi_\eta(t)) \leq \psi(\xi_\eta(t))$ for all $t \in [0, T]$. Applying Proposition 4.2, we have

$$\psi(x_0) = w(x_0) \leq \sup_{B^T} \{ \mathcal{I}_{x_0}^T(\eta, \bar{\gamma}) + w(\xi_\eta(T)) \} \leq \sup_{B^T} \{ \mathcal{I}_{x_0}^T(\eta, \bar{\gamma}) + \psi(\xi_\eta(T)) \}.$$

Hence, we get

$$\sup_{\eta \in B^t} \left\{ \int_0^t \langle \bar{\gamma}[\eta](s), D\psi(\xi_\eta(s)) - \eta(s) \rangle - d^\sharp(\eta(s), Z(\xi_\eta(s))) \right\} \geq 0,$$

which contradicts the Claim. The proof is concluded. \square

Proposition 4.4. *w is a supersolution of (1) in $\mathbb{R}^n \setminus K$.*

Proof. The argument is by contradiction. Assume there exist $y_0 \in \mathbb{R}^n \setminus K$ and a strict subgradient φ to w at y_0 , with $w(y_0) = \varphi(y_0)$, such that

$$d^\sharp(D\varphi(y_0), Z(y_0)) < 0.$$

Consequently

$$(10) \quad h(y) := |D\varphi(y) - D\varphi(y_0)| + d^\sharp(D\varphi(y_0), Z(y)) < 0$$

in some neighborhood V of y_0 with closure contained in $\mathbb{R}^n \setminus K$.

Set $\varepsilon = \min_{\partial V} (w - \varphi) > 0$, and select a nonanticipating strategy $\bar{\gamma} : B \rightarrow B_{y_0, K}$ with

$$w(y_0) \geq \sup_{\eta \in B} \mathcal{I}_{y_0}(\eta, \bar{\gamma}) + g(\bar{\xi}(1)) - \frac{\varepsilon}{2}.$$

Set $\bar{\eta} \equiv D\varphi(y_0)$, since the closure of V is disjoint from K the trajectory $\bar{\xi}(t) := \xi_{y_0}^{\bar{\eta}, \bar{\gamma}}(t)$ must intersect ∂V , we denote by \bar{t} the first time when such intersection takes place. Note that here we are essentially exploiting that $y_0 \notin K$. Given $\sigma \in B^{1-\bar{t}}$, we define

$$\eta_\sigma(s) := \begin{cases} D\varphi(y_0) & \text{for } s \in [0, \bar{t}] \\ \sigma(s - \bar{t}) & \text{for } s \in [\bar{t}, 1] \end{cases}$$

Thanks to the nonanticipating character of $\bar{\gamma}$, we get a new nonanticipating strategy $\delta : B^{1-\bar{t}} \rightarrow B_{\bar{\xi}(\bar{t}), K}^{1-\bar{t}}$ by setting $\delta(\sigma(s)) = \bar{\gamma}(\eta_\sigma(s + \bar{t}))$ for every $\sigma \in B^{1-\bar{t}}$. Therefore

$$\begin{aligned} w(y_0) &\geq \mathcal{I}_{y_0}^{\bar{t}}(\bar{\eta}, \bar{\gamma}) + \sup_{\sigma \in B^{1-\bar{t}}} \left\{ \mathcal{I}_{\bar{\xi}(\bar{t})}^{1-\bar{t}}(\sigma, \delta) + g(\hat{\xi}_\sigma(1 - \bar{t})) - \frac{\varepsilon}{2} \right\} \\ &\geq \mathcal{I}_{y_0}^{\bar{t}}(\bar{\eta}, \bar{\gamma}) + w(\bar{\xi}(\bar{t})) - \frac{\varepsilon}{2} \geq \mathcal{I}_{y_0}^{\bar{t}}(\bar{\eta}, \bar{\gamma}) + \varphi(\bar{\xi}(\bar{t})) + \frac{\varepsilon}{2}, \end{aligned}$$

where $\hat{\xi}_\sigma(t) = \bar{\xi}(\bar{t}) + \int_0^t \delta[\sigma](s) ds$ for $t \in [0, 1 - \bar{t}]$. Finally

$$\begin{aligned} \frac{\varepsilon}{2} &\leq \int_0^{\bar{t}} \langle \bar{\gamma}[\bar{\eta}], \bar{\eta} - D\varphi(\bar{\xi}) \rangle + |\bar{\gamma}(\bar{\eta})| d^\#(\eta, Z(\bar{\xi})) ds \\ &\leq \int_0^{\bar{t}} |\bar{\gamma}[\bar{\eta}]| [|D\varphi(y_0) - D\varphi(\bar{\xi})| + d^\#(\eta, Z(\bar{\xi}))] ds \\ &\leq \int_0^{\bar{t}} |\bar{\gamma}[\bar{\eta}]| h(\bar{\xi}) ds. \end{aligned}$$

This is impossible since $\bar{\xi}(t) \in V$ for all $t \in [0, \bar{t}]$ and (10) holds. \square

The inf-sup representation formula we have introduced possess a stability property with respect to the uniform convergence, as specified by the following result.

Proposition 4.5. *Set for any $g \in C^0(K)$*

$$(Tg)(x) = \inf_{\gamma \in \Gamma_{x, K}} \sup_{\eta \in B} \{ \mathcal{I}_x(\gamma, \eta) + g(\xi_x^{\eta, \gamma}(1)) \},$$

for $x \in \mathbb{R}^n$. If g_n is a sequence of $C^0(K)$ uniformly converging to some g_∞ then $Tg_n \rightarrow Tg_\infty$ locally uniformly in \mathbb{R}^n .

Proof. Set $w_n = Tg_n$, $w_\infty = Tg_\infty$ and fix a compact subset C in \mathbb{R}^n , by Proposition 4.1 w_n and w_∞ are equiLipschitz-continuous in C . We denote by M a common Lipschitz constant for them. Fix $\varepsilon > 0$, by compactness of C there exist a positive integer N and $x_1, \dots, x_N \in C$ such that

$$\min\{|x_i - x| : i = 1 \dots N\} < \varepsilon \quad \text{for any } x \in C.$$

Let n be such that $\|g - g_n\|_{\infty, K} < \varepsilon$, we can find strategies $\bar{\gamma}_i \in \Gamma_{x_i, K}$ such that

$$w_n(x_i) \geq \sup_{\eta \in B} \{ \mathcal{I}_{x_i}(\bar{\gamma}_i, \eta) + g_n(\xi_{x_i}^{\eta, \bar{\gamma}_i}(1)) \} - \varepsilon,$$

and $\bar{\eta}_i \in B$ with

$$\sup_{\eta \in B} \{ \mathcal{I}_{x_i}(\bar{\gamma}_i, \eta) + g_\infty(\xi_{x_i}^{\eta, \bar{\gamma}_i}(1)) \} \leq \mathcal{I}_{x_i}(\bar{\gamma}_i, \bar{\eta}_i) + g_\infty(\xi_{x_i}^{\bar{\eta}_i, \bar{\gamma}_i}(1)) + \varepsilon,$$

for every $i = 1 \dots N$. Given $x \in C$, we deduce for a suitable i

$$\begin{aligned} w_\infty(x) - w_n(x) &= w_\infty(x) - w_\infty(x_i) + w_\infty(x_i) - w_n(x_i) + w_n(x_i) - w_n(x) \\ &\leq 2M|x - x_i| + w_\infty(x_i) - w_n(x_i) \\ &\leq 2M\varepsilon + \sup_{\eta \in B} \{ \mathcal{I}_{x_i}(\bar{\gamma}_i, \eta) + g_\infty(\xi_{x_i}^{\eta, \bar{\gamma}_i}(1)) \} - \sup_{\eta \in B} \{ \mathcal{I}_{x_i}(\bar{\gamma}_i, \eta) + g_n(\xi_{x_i}^{\eta, \bar{\gamma}_i}(1)) \} + \varepsilon \\ &\leq 2M\varepsilon + \mathcal{I}_{x_i}(\bar{\gamma}_i, \bar{\eta}_i) + g_\infty(\xi_{x_i}^{\bar{\eta}_i, \bar{\gamma}_i}(1)) + \varepsilon - \mathcal{I}_{x_i}(\bar{\gamma}_i, \bar{\eta}_i) - g_n(\xi_{x_i}^{\bar{\eta}_i, \bar{\gamma}_i}(1)) + \varepsilon \\ &\leq 2M\varepsilon + \|g_n - g_\infty\|_{\infty, K} + 2\varepsilon < (2M + 3)\varepsilon. \end{aligned}$$

Exchanging the role of w_n and w_∞ , we obtain the same estimate of above for $w_n(x) - w_\infty(x)$, hence the proof is concluded taking into account that ε is arbitrary. \square

5. COMPATIBILITY CONDITIONS FOR THE BOUNDARY DATA

Here we focus our attention to the Dirichlet problem (6). Thanks to the results of the previous section, we know that the function w defined in (7) with $\partial\Omega$ in place of K is a solution in Ω of equation (1).

To show that w actually solves (6), one has to introduce, as in the convex case, compatibility requirements on the boundary datum ensuring that w agrees with it on $\partial\Omega$. We recall that in the case where the Hamiltonian is convex, a sufficient condition for this is that g is 1 Lipschitz-continuous with respect to the distance related to the Hamiltonian. This is not true any more if H is nonconvex. More generally, we introduce in the next proposition a class of boundary data g satisfying

$$(11) \quad g(x) - g(y) \leq S(y, x) \quad \text{for } x, y \text{ in } \partial\Omega,$$

for which the Dirichlet problem (6) does not admit any solution. This result generalizes Theorem 3.1 in [4], in the fact that we take Hamiltonians not necessarily independent of state variable, but just with 0-sublevels possessing constant convex hull. In addition our argument is definitely simpler than that used in [4].

Proposition 5.1. *Let Ω be a bounded open domain of \mathbb{R}^n . Assume the Hamiltonian H such that its 0 sublevels satisfy $\text{co}Z(\cdot) =: C$ constant, and $\partial C \setminus \cup_{x \in \bar{\Omega}} Z(x) \neq \emptyset$, then there is $p \in \text{int}C$ such that the problem (6) with boundary datum $g(x) = \langle p, x \rangle$ does not admit any solution.*

Note that under the previous assumptions $S = L$ by Proposition 3.3 and so the linear datum, appearing in the statement, satisfies (11). Further we point out that the argument we are going to use for proving Proposition 5.1 actually shows a more general assertion, namely that if $p_0 \in \partial C \setminus \cup_{x \in \bar{\Omega}} Z(x)$ then any boundary datum obtained through suitably small perturbation of $x \mapsto \langle p_0, x \rangle$ in $C^0(\partial\Omega)$ gives rise to a Dirichlet problem not admitting any solution.

Proof. First select $p_0 \in \partial C \setminus \cup_{x \in \bar{\Omega}} Z(x)$ $p_n \in \text{int}C$ converging to p_0 , set $g_n(x) = \langle p_n, x \rangle$ and assume by contradiction that there is a solution u_n to (6) in Ω , with g_n in place of g . It must be

$$(12) \quad u_n(x) < \langle p_n, x \rangle \quad \text{for any } x \in \Omega,$$

for n sufficiently large, otherwise $\langle p_n, \cdot \rangle$ should be supertangent to u at some point of Ω , which is impossible since u_n is a solution in Ω and $p_n \notin Z(x)$, when n is large enough, for any $x \in \Omega$, by the continuity properties of the set-valued function $Z(\cdot)$. By the coercivity assumption (H4) on H the u_n are equiLipschitz-continuous with respect the geodetic Euclidean distance in Ω , denoted by d^Ω , and, bearing in mind

that they take continuously the value g_n on $\partial\Omega$, we can invoke Ascoli Theorem to derive that they locally uniformly converge, up to a subsequence, to some u in Ω , which is locally Lipschitz-continuous in Ω . By straightforward stability properties of viscosity solutions, see [1], u is solution of (1) in Ω , furthermore by (12)

$$\limsup_{x \rightarrow y} u(x) \leq \langle p_0, y \rangle \quad \text{for any } y \in \partial\Omega,$$

and so we can argue as above, to deduce

$$(13) \quad u(x) < \langle p_0, x \rangle \quad \text{for any } x \in \Omega.$$

We proceed by picking $v \neq 0$ in $N_C(p_0)$, x in Ω with $x + v \in \partial\Omega$ and $x + tv \in \Omega$ for $t \in [0, 1)$. We set

$$I = \{x + tv : t \in [0, 1)\},$$

since $d_\Omega(x_1, x_2) = |x_1 - x_2|$ for x_1, x_2 in I , the u_n are equiLipschitz-continuous in I and so they uniformly converge in I , up to further extraction of a subsequence, to some Lipschitz-continuous function which must coincide with u . Therefore, since $u_n(x + v) = g_n(x + v)$ for any n

$$\lim_{t \rightarrow 1} u(x + tv) = \langle p_0, x + v \rangle,$$

which implies

$$(14) \quad \langle p_0, x + v \rangle - u(x) = \int_0^1 \frac{d}{dt} u(x + tv) dt.$$

We know from [5] that

$$\frac{d}{dt} u(x + tv) = \langle p(t), v \rangle \quad \text{for a.e. } t \in (0, 1) \text{ and some } p(t) \in \partial u(x + tv),$$

since $\partial u(x + tv) \subset C$ for any $t \in (0, 1)$, being u a solution (1) in Ω , and $v \in N_C(p_0)$ we deduce from (14)

$$\langle p_0, x + v \rangle - u(x) \leq \langle p_0, v \rangle$$

and, taking into account (13)

$$\langle p_0, x + v \rangle - \langle p_0, x \rangle < \langle p_0, x + v \rangle - u(x) \leq \langle p_0, v \rangle,$$

which is impossible. □

The next example, which is a development of Example 3.1, shows a boundary datum g of different nature with respect to those considered in the previous proposition, satisfying (11), with $g \neq w$ at some point of the boundary, where w is defined as in (7). Sufficient conditions for w in order to take the value g on the boundary of Ω will be presented later; according to Proposition 4.5 the compatible boundary datum make up a closed subset in $C^0(\partial\Omega)$ with respect to the uniform convergence.

Example 5.1. Our ground space is \mathbb{R}^2 . We set $\Omega' = B((0, 0), 1)$, $\Omega = \Omega' \setminus \{(0, 0)\}$, and define Z, H as in Example 3.1. Notice that $\partial\Omega = \{(0, 0)\} \cup \partial\Omega'$. We consider Dirichlet problem (5) in Ω with boundary datum

$$g \equiv 0 \text{ on } \partial\Omega', \quad g(0, 0) = 1/2.$$

In order to show that (11) holds, we introduce a convex Hamiltonian, say $\bar{H}(p)$, with $\text{co}(Z)$ as 0-sublevel set and consider the auxiliary Dirichlet problem:

$$\begin{cases} \bar{H}(x, Dv) = 0 & \text{for } x \in \Omega' \\ u(x) = 0 & \text{for } x \in \partial\Omega' \end{cases}$$

The unique solution is given by

$$w_0(x) := \min\{L(y, x) : y \in \partial\Omega'\}.$$

As shown in Example 3.1, w_0 takes the value $\frac{1}{2}$ at $(0, 0)$, which actually shows the validity of (11) taking into account that the intrinsic distances S and L coincide, since the Hamiltonian is independent of x . Let w be defined as in (7). We claim that $w = g$ on $\partial\Omega'$, but $w(0, 0) < g(0, 0) = 1/2$. Setting $\bar{\eta} \equiv 0$, we have

$$\begin{aligned} w(x) &= \inf_{\gamma \in \Gamma_{x, \partial\Omega}} \mathcal{I}_x(\bar{\eta}, \gamma) + g(\xi_x^{\bar{\eta}, \gamma}(1)) \\ &\geq \inf_{\gamma \in \Gamma_{x, \partial\Omega}} \int_0^1 -|\gamma[\eta](t)| d^\#(0, Z(\xi_x^{\bar{\eta}, \gamma}(t))) dt + g(\xi_x^{\bar{\eta}, \gamma}(1)) \geq 0, \end{aligned}$$

which directly implies that w vanishes on $\partial\Omega'$ being the inequality $w \leq g$ always true.

We define \tilde{w} via formula (7) with Ω' and the null function in place of Ω and g . We emphasize that the boundary datum for \tilde{w} is set equal 0 at 0. Notice, further, that $\tilde{w} \leq w_0$ in Ω' . From $\Gamma_{x, \partial\Omega} \supseteq \Gamma_{x, (0,0)} \cup \Gamma_{x, \partial\Omega'}$, it follows

$$w(x) \leq \min\{S((0, 0), x) + \frac{1}{2}, \tilde{w}(x)\},$$

and so

$$w(0) \leq \min\left\{\frac{1}{2}, \tilde{w}(0, 0)\right\}.$$

To prove the final part of our claim, it is then sufficient to show the strict inequality $\tilde{w}(0, 0) < 1/2 = w_0(0, 0)$. For this, we recall that in Example 3.1, we have constructed a supertangent ψ to w_0 at $(0, 0)$ with $D\psi(0, 0) \in \text{co}(Z) \setminus Z$. If $\tilde{w}(0, 0) = \frac{1}{2}$, then ψ should be also a supertangent to \tilde{w} at $(0, 0)$, which is impossible, since \tilde{w} is a solution to (1) in Ω' .

As announced, we proceed by presenting some results giving sufficient conditions in order to ensure the equality $w = g$ on $\partial\Omega$ under suitable assumptions on $\partial\Omega$, the boundary datum and the sublevels of the Hamiltonian. This clearly implies that w solves the Dirichlet problem (5). Notice that, according to Proposition 4.1, it is actually enough to prove that $w \geq g$ on $\partial\Omega$. The strategy of the proofs can be summarized as follows:

- (1) we make some geometric global requirement on the datum, on the domain Ω and on the sublevel Z .
- (2) by taking, in the formula defining w , the covector curve η constant, we get an estimate from below of w ; notice that in this case the first term in the integral expressing $\mathcal{I}_x(\gamma, \eta)$ is independent of the strategy.

In the first proposition we require a Lipschitz continuity of the boundary datum g with respect to the metric L_1 given by

$$L_1(y, x) = \inf \left\{ \int_0^1 |\dot{\xi}| d(0, \partial Z(\xi(t))) dt : \xi : [0, 1] \rightarrow \mathbb{R}^N \text{ Lipschitz-continuous, } \xi(0) = y, \xi(1) = x \right\}.$$

for any x, y in \mathbb{R}^n . Notice that L_1 can be equivalently defined as L with the support function of $B(0, d(0, \partial Z(\cdot)))$ replacing that of $Z(\cdot)$. From this we see that L_1 is of Finsler type. Note that if the Hamiltonian is independent of x and $Z := \{p : H(p) \leq 0\}$ then $L_1(y, x) = d(0, \partial Z) d^\Omega(y, x)$, for any x, y ; if furthermore Ω is convex, $L_1(y, x) = d(0, \partial Z) |y - x|$.

Proposition 5.2. *If g satisfies $g(x) - g(y) \leq L_1(y, x)$ for all $x, y \in \partial\Omega$, then the function w defined in (7) takes the value g on $\partial\Omega$, and so is a solution of the Dirichlet problem (6).*

Proof. In view of Proposition 4.1 it is enough to prove the inequality $w \geq u$ on $\partial\Omega$. For this set $\bar{\eta} \equiv 0$ and compute

$$\begin{aligned} w(x) &\geq \inf_{\gamma \in \Gamma_{x, \partial\Omega}} \mathcal{I}_x(\bar{\eta}, \gamma) + g(\xi_x^{\bar{\eta}, \gamma}(1)) \\ &= \inf_{\gamma \in \Gamma_{x, \partial\Omega}} \int_0^1 -|\gamma[\bar{\eta}](t)| d^\sharp(0, Z(\xi_x^{\bar{\eta}, \gamma}(t))) dt + g(\xi_x^{\bar{\eta}, \gamma}(1)) \\ &= \inf_{y \in \partial\Omega} L_1(y, x) + g(y) = g(x). \end{aligned}$$

□

The interesting point in the following propositions is that, in order to get the equality $w = g$, we assume conditions on g and $\partial\Omega$. Loosely speaking, they prevent the points of the boundary giving a contribution to the determination of $w(x)$ from being too far from x . In the next proposition it is in particular assumed some convexity on the boundary datum. The Hamiltonian is taken independent of the state variable.

Proposition 5.3. *Let $H = H(p)$ and denote by Z its 0-sublevel. Assume that g is the trace on $\partial\Omega$ of a convex function \bar{g} defined in \mathbb{R}^n . If $Z \cap D^- \bar{g}(x) \neq \emptyset$, for all $x \in \partial\Omega$, then the function w , defined as in (7), agrees with g on $\partial\Omega$, and so is a solution of (6).*

Proof. Let x be in $\partial\Omega$, we denote by p an element of $Z \cap D^- \bar{g}(x)$. Since \bar{g} is convex

$$g(x) \leq g(y) - \langle p, y - x \rangle \quad \text{for all } y \in \partial\Omega.$$

Set $\bar{\eta} \equiv p$. We have

$$\begin{aligned} w(x) &\geq \inf_{\gamma \in \Gamma_{x, \partial\Omega}} \{ \mathcal{I}_x(\bar{\eta}, \gamma) + g(\xi_x^{\bar{\eta}, \gamma}(1)) \} \geq \inf_{\gamma \in \Gamma_{x, \partial\Omega}} \left\{ \int_0^1 -\langle \gamma[\bar{\eta}](t), p \rangle dt + g(\xi_x^{\bar{\eta}, \gamma}(1)) \right\} \\ &= \inf_{y \in \partial\Omega} \{ -\langle p, y - x \rangle + g(y) \} = g(x) \end{aligned}$$

□

If Ω is convex then any constant boundary datum is the trace of the convex function $\bar{g}_{a,b} := a d(\cdot, \Omega) + b$ for a suitable b and any $a > 0$. In this case the condition $N_\Omega(x) \cap Z \neq \emptyset$ for any $x \in \partial\Omega$ guarantees that $w = g$. This is in fact a consequence of Proposition 5.2 since we are assuming $0 \in Z$.

If Ω is convex and the boundary datum nonconstant, we have

Proposition 5.4. *Let H, Z, w as in Proposition 5.3. Let Ω be convex and assume, in addition, that for all $x \in \partial\Omega$ there exists $p = p(x) \in N_\Omega(x) \cap Z$ with $d(p, \partial Z) \geq L$.*

If the boundary datum g is Lipschitz-continuous with Lipschitz constant L then $g = w$ on $\partial\Omega$.

This proposition should be compared to Theorem 2.6 in [4] and Theorem 7. in [6]. We will obtain it as a special case of the forthcoming Proposition 5.5, where we will make use of the proximal normal cone to $\partial\Omega$. Before doing that, we point out in the following example that the Lipschitz estimates on the boundary datum required in Propositions 5.2 and 5.4 to get the equality $w = g$ can be very different.

Example 5.2. The ground space is \mathbb{R}^2 . Fix $\varepsilon > 0$, and set $\Omega = [-1, 1] \times [-1, 1]$, note that the geodetic distance d^Ω coincides with the Euclidean one, being Ω convex. Define

$$\begin{aligned} T_1 &= \text{co}\{(0, 0), (2, \pm\sqrt{3})\} \quad , \quad T_2 = \text{co}\{(0, 0), (-2, \pm\sqrt{3})\} \\ T_3 &= \text{co}\{(0, 0), (\pm\sqrt{3}, 2)\} \quad , \quad T_4 = \text{co}\{(0, 0), (\pm\sqrt{3}, -2)\} \end{aligned}$$

and set

$$Z = \left([-1, 1] \times [-\varepsilon, \varepsilon]\right) \cup \left([-\varepsilon, \varepsilon] \times [-1, 1]\right) \cup \bigcup_{k=1}^4 T_k.$$

Notice that, for all $x \in \partial\Omega$, $N_\Omega(x) \cap Z$ contains at least one vector among $(\pm 1, 0)$ and $(0, \pm 1)$, and all these vectors stay at an Euclidean distance $\frac{1}{2}$ from ∂Z . Proposition 5.4 then guarantees the equality $w = g$ for any Lipschitz-continuous boundary datum with Lipschitz constant greater than or equal to $\frac{1}{2}$. An application of Proposition 5.2 allows to reach the same conclusion only if $L \leq d(0, \partial\Omega) = \varepsilon\sqrt{2}$, and ε can be of course taken arbitrarily small.

Proposition 5.5. Let H be independent of x , w defined as in (7), and g Lipschitz-continuous with Lipschitz constant L .

Assume that for every $x \in \partial\Omega$ there exists $p = p(x) \in N_{\partial\Omega}^P(x) \cap Z$ with

$$|x - y|(d(p, \partial Z) - L) \geq \rho |p| |y - x|^2 \text{ for every } y \in \partial\Omega,$$

where $\rho = \rho(p)$ is the positive constant appearing in the definition of proximal normal (see Definition 2.2). Then $w = g$ on $\partial\Omega$.

Proof. Given $x \in \partial\Omega$, and p enjoying the properties of the statement with respect to x . We set $\bar{\eta} \equiv p$, we have

$$\begin{aligned} w(x) &\geq \inf_{\gamma \in \Gamma_{x, \partial\Omega}} \left\{ \int_0^1 (-\gamma[\bar{\eta}]p + d(p, \partial Z)|\gamma[\bar{\eta}]|) dt + g(\xi_x^{\bar{\eta}, \gamma}(1)) \right\} \\ &\geq \inf_{y \in \partial\Omega} \langle -p, y - x \rangle + d(p, \partial Z) |y - x| + g(y) \\ &\geq \inf_{y \in \partial\Omega} \{-\rho |p| |y - x|^2 + d(p, \partial Z) |y - x| + g(y) - g(x)\} + g(x) \\ &\geq \inf_{y \in \partial\Omega} \{-\rho |p| |y - x|^2 + (d(p, \partial Z) - L) |y - x|\} + g(x) = g(x) \end{aligned}$$

□

Proposition 5.3 can be suitably generalized weakening the convexity condition on g . We preliminary recall that a function f defined in \mathbb{R}^n is called *semiconvex* if $f + \alpha|x|^2$ is convex for some positive α . Note that in this case $f + \alpha|x - y|^2$ is also convex for any $y \in \mathbb{R}^n$. Such an α is named semiconvexity constant for f . For a semiconvex function f , $D^-f(x) = \partial f(x)$ for all x , and

$$(15) \quad f(y) \geq f(x) + \langle p, y - x \rangle - \alpha|y - x|^2 \quad \text{for any } x, y, p \in D^-f(x).$$

A function f is called semiconcave iff $-f$ is semiconvex. We refer to [3] for properties of semiconcave and semiconvex functions.

Proposition 5.6. *Let H, Z, w be as in Proposition 5.3. Assume that g is the trace on $\partial\Omega$ of a semiconvex function \tilde{g} , defined in \mathbb{R}^n , with semiconvexity constant α . If for all $x \in \partial\Omega$ there is $p = p(x) \in Z \cap D^-\tilde{g}(x)$ with $\alpha \text{diam}(\Omega) \leq d(p, \partial Z)$, then $w = g$ on $\partial\Omega$, and therefore w is a solution of the Dirichlet problem (6).*

Proof. We fix $x \in \partial\Omega$, $p = p(x)$ with the properties appearing in the statement and set, as in the proof of Proposition 5.3, $\bar{\eta} = p$, we exploit the assumption and (15) to get

$$\begin{aligned} w(x) &\geq \inf_{\Gamma_{x, \partial\Omega}} \left\{ \int_0^1 -\gamma[\bar{\eta}](t)p + |\gamma[\bar{\eta}](t)|d(p, \partial Z) dt + g(\xi_x^{\bar{\eta}, \gamma}(1)) \right\} \\ &\geq \inf_{y \in \partial\Omega} \{ -\langle p, y - x \rangle + d(p, \partial Z)|y - x| + g(y) \} \\ &\geq \inf_{y \in \partial\Omega} \{ -\langle p, y - x \rangle + \alpha|y - x|^2 + g(y) \} \geq g(x). \end{aligned}$$

This concludes the proof. \square

Note that if the \tilde{g} appearing in the previous statement is convex, then $\alpha = 0$ and we recognize that Proposition 5.3 is actually a special case of Proposition 5.6. We end the section by stating and proving a couple of comparison principles.

Proposition 5.7. *Let Ω be a bounded open subset of \mathbb{R}^n . Assume $Z(x)$ to be strictly star-shaped with respect to 0 for every $x \in \Omega$. Then if u, v are super and subsolutions to $H = 0$ in Ω , respectively, lower and upper semicontinuous in $\bar{\Omega}$, respectively, and $u \geq v$ on $\partial\Omega$, then $u \geq v$ on the whole of Ω .*

We note that, by the coerciveness of the Hamiltonian, the subsolution v is indeed locally Lipschitz-continuous in Ω .

Proof. Assume by contradiction that the minimum of $u - v$ in $\bar{\Omega}$ is strictly negative. Taking into account that $u - v$ is l.s.c., and nonnegative on $\partial\Omega$ by assumption, we find a positive constant ρ such that any minimizer of $u - v$ is at distance greater than ρ from $\partial\Omega$. Therefore there is an open set B compactly contained in Ω containing all such minimizers. We select λ close to 1 for which the minimizers of $u - \lambda v$ are still contained in B . Because of star-shapedness of $Z(x)$, continuity of H and the fact that $\bar{\Omega}$ is compact, the function $v_\lambda := \lambda v$ satisfies

$$(16) \quad H(x, Dv_\lambda) \leq -\delta \quad \text{in the viscosity sense in } \Omega,$$

for some positive δ . For each $n \in \mathbb{N}$, we consider the Moreau sup-convolution of $v_\lambda(x)$

$$v_{\lambda, n}(x) = \sup_{y \in \bar{\Omega}} \left\{ v_\lambda(y) - \frac{n}{2}|x - y|^2 \right\},$$

and the Moreau inf-convolution of $u(x)$

$$u_n(x) = \inf_{y \in \Omega} \left\{ u(y) + \frac{n}{2} |x - y|^2 \right\},$$

with $x \in B$. The functions v_λ, u are the weak upper semilimit of $v_{\lambda,n}$ and the weak lower semilimit of u_n in B , respectively, as n goes to infinity. This means:

$$\begin{aligned} v_\lambda(x) &= \sup_n \{ \limsup v_{\lambda,n}(x_n) : x_n \rightarrow x \} \\ u(x) &= \inf_n \{ \liminf u_n(x_n) : x_n \rightarrow x \} \end{aligned}$$

We can therefore select n sufficiently large such that $u_n - v_{\lambda,n}$ has a minimizer \bar{x} in \bar{B} belonging to B . By exploiting basic properties of sub(super)-convolution, (16), and the continuous character of the Hamiltonian, we can also assume, without loosing generality, that for such an n

$$H(x, Du_n) \geq -\frac{\delta}{3}, \quad H(x, Dv_{\lambda,n}) \leq -\delta/2 \quad \text{in the viscosity sense in } B.$$

Since $u_n, v_{\lambda,n}$ are semiconcave and semiconvex, respectively, and so $D^-v_{\lambda,n}(\bar{x})$ and $D^+u_n(\bar{x})$ are nonempty, we deduce that such functions are both differentiable at the minimizer \bar{x} with $Du_n(\bar{x}) = Dv_{\lambda,n}(\bar{x}) =: p_0$. This implies the inequalities

$$H(\bar{x}, p_0) \geq -\delta/3, \quad H(\bar{x}, p_0) \leq -\delta/2,$$

which are contradictory. □

If some of the conditions ensuring that g and w , defined in (7) with $\partial\Omega$ in place of K , agree on $\partial\Omega$ hold and we are in the setting of the previous proposition, then we directly deduce that w is indeed the unique solution of (6).

Proposition 5.8. *Let K, H be a compact subset of \mathbb{R}^n and an Hamiltonian independent of x with 0-sublevel Z strictly star-shaped with respect to 0, respectively. Assume that u and v are super and subsolution of $H = 0$ in $\mathbb{R}^n \setminus K$, respectively, lower and upper semicontinuous in $\overline{\mathbb{R}^n \setminus K}$, respectively, with $u \geq v$ in ∂K and*

$$\lim_{|x| \rightarrow +\infty} u(x) = \lim_{|x| \rightarrow +\infty} v(x) + \infty.$$

Then $u \geq v$ on the whole $\mathbb{R}^n \setminus K$.

Proof. We denote by ρ the gauge function of Z , namely

$$\rho(p) = \inf \left\{ \lambda > 0 : \frac{p}{\lambda} \in Z \right\}.$$

Due to the star-shapedness assumption on Z , it is continuous and clearly nonconvex in general, moreover the equation $H(Du) = 0$ is equivalent to

$$(17) \quad \rho(Du) = 1$$

in the sense that they have the same (sub,super)solutions. The advantage of ρ is that it is positively homogeneous so that we can apply Kruzkov transform to prove the result.

Assume by contradiction that

$$(18) \quad v(x_0) > u(x_0) \quad \text{for some } x_0 \in \mathbb{R}^n \setminus K.$$

We set

$$v_1 = 1 - e^{-v(x)} \quad \text{and} \quad u_1 = 1 - e^{-u(x)};$$

such functions are sub and supersolution of

$$\begin{cases} \varphi + \rho(D\varphi) = 1 & \text{in } \mathbb{R}^n \setminus K \\ \lim_{|x| \rightarrow +\infty} \varphi(x) = 1 \end{cases}$$

and the inequality $u_1 \geq v_1$ holds on ∂K . The argument to conclude is well known, we just sketch it for reader's convenience. We introduce a sequence of upper semi-continuous auxiliary functions $\Phi_n : \mathbb{R}^n \times \mathbb{R}^n \rightarrow \mathbb{R}$, $n \in \mathbb{N}$, defined by

$$\Phi_n(x, y) = v_1(x) - u_1(y) - n|x - y|^2.$$

We show that there is a sequence (x_n, y_n) of global maximizers of F_n in $\overline{\mathbb{R}^n \setminus K} \times \overline{\mathbb{R}^n \setminus K}$ and, because of (18), both x_n and y_n converge, up to a subsequence, to some element of $\mathbb{R}^n \setminus K$. Therefore $(x_n, y_n) \in \mathbb{R}^n \setminus K \times \mathbb{R}^n \setminus K$ for n sufficiently large and

$$(19) \quad v_1(x_n) - u_1(y_n) \geq \Phi_n(x_n, y_n) \geq v_1(x_0) - u_1(y_0) > 0$$

Now we observe that the functions

$$\begin{aligned} &u_1(y_n) + n|x - y_n|^2 \\ &v_1(x_n) - n|x_n - y|^2 \end{aligned}$$

are supertangent to v_1 at x_n and subtangent to u_1 at y_n , respectively, and get

$$\begin{aligned} v_1(x_n) + \rho(2n(x_n - y_n)) &\leq 1 \\ u_1(y_n) + \rho(2n(x_n - y_n)) &\geq 1. \end{aligned}$$

By subtracting these two formulae, we finally reach a contradiction with (19). \square

6. THE CRITICAL CASE

In this section we exploit the metric formulae previously obtained to perform some qualitative analysis of $H(x, Du) = 0$ in the case where 0 is the critical value for H and the equilibria set \mathcal{E} is nonempty. More precisely, we illustrate through some examples how the metric setup is quite different from the convex case.

As explained in the Introduction, if the Hamiltonian is convex a crucial role is played in the study of the critical equation by the so-called Aubry set, made up by points around which the intrinsic distance related to the Hamiltonian fails to be equivalent to the Euclidean metric. This can be expressed, more precisely, comparing the intrinsic and the natural length of cycles, as follows.

Definition 6.1. Let H be convex with critical value 0 and 0-sublevels denoted by $Z(\cdot)$, the Aubry set \mathcal{A} is made up by points y such that there exists a sequence ξ_n of cycles passing through y and defined in $[0, 1]$ with

$$\inf_n \int_0^1 \sigma_{Z(\xi_n(t))}(\dot{\xi}_n) dt = 0 \quad , \quad \inf_n \int_0^1 |\dot{\xi}_n(s)| ds > 0$$

The Aubry set is nonempty for convex critical Hamilton–Jacobi equations posed on compact space, for instance on the flat torus \mathbb{T}^n . In this case the critical equation $H = 0$ is the unique in the one parameter family of Hamilton–Jacobi equations $H(x, Du) = a$ admitting a solution on the whole \mathbb{T}^n . This relevant property of the critical value is also maintained in the nonconvex case, see [8] We recall, for later use, some properties of the Aubry set for H convex with critical value 0:

- (1) $y \in \mathcal{A}$ iff $L(y, \cdot)$ is a solution of $H(x, Du) = 0$ (in general it is only a subsolution);
- (2) if w is a subsolution of $H = 0$ and $y \in \mathcal{A}$ then $D^+w(y) \cup D^-w(y) \subseteq \partial Z(y)$;
- (3) if $y \notin \mathcal{A}$ then $\partial L_y(y) = D^-L_y(y) = Z(y)$, where $L_y := L(y, \cdot)$.

In our setting, if H is convex, \mathcal{A} coincides with the set of equilibria \mathcal{E} , defined in (2), as can be easily deduced, for instance, by the above items (1), (2). If H is not convex it is an important open problem to understand if something similar to the Aubry set can exist at the critical value and how it can be defined. In case of positive answer to this question, it is sensible to hypothesize by what previously outlined that, under our assumptions, such a set should coincide with or be contained in \mathcal{E} . We actually prove in the next result that item (1) in the previous list holds for \mathcal{E} ; on the other side we exhibit examples showing that no degeneration phenomena of the intrinsic distance take place around the points of \mathcal{E} and the equilibria do not enjoy in general the properties (2), (3).

Proposition 6.1. *Let 0 be the critical value of H then $S(y, \cdot)$ is a solution of $H = 0$ on the whole \mathbb{R}^n if and only if $y \in \mathcal{E}$, and the function*

$$u(x) = \inf_{\gamma \in \Gamma_{x, \mathcal{E}}} \sup_{\eta \in B} \{\mathcal{I}_x(\eta, \gamma)\}$$

is a critical solution vanishing on \mathcal{E} .

Proof. We know from Proposition 3.2 that $S(y, \cdot)$ is subsolution in \mathbb{R}^n and solution in $\mathbb{R}^n \setminus \{y\}$ for any y . If, in addition, $y \in \mathcal{E}$ then $H(y, p) \geq 0$ for any p and so the subtangency test for $S(y, \cdot)$ is automatically satisfied at y .

Conversely, if $y \notin \mathcal{E}$ then $0 \in \text{int}(Z(y))$ and so $H(y, 0) < 0$. Taking into account that $S(y, \cdot)$ is nonnegative by Proposition 3.1 ii. and vanishes at y , we see that the null function is subtangent to $S(y, \cdot)$ at y . Hence $S(y, \cdot)$ is not a critical solution.

In the light of Theorem 4.1 and Proposition 5.2, we see that the function u appearing in the statement is solution to $H = 0$ in $\mathbb{R}^n \setminus \mathcal{E}$ and takes continuously the value 0 on \mathcal{E} . Arguing as in the first part of the proof, we also prove that it is supersolution on \mathcal{E} , moreover any equilibrium is a minimizer of u since u is nonnegative on \mathbb{R}^n . Therefore if $D^+u(y) \neq \emptyset$ at some $y \in \mathcal{E}$ then u is differentiable at y with $Du(y) = 0$. Since $H(y, 0) = 0$ we conclude that u is also subsolution on \mathcal{E} . \square

Example 6.1. Consider the following family of closed subsets of \mathbb{R}^2 , parametrized by $x \in \mathbb{R}^2$:

$$\begin{aligned} Z(x) &:= \{p = (p_1, p_2) \in \mathbb{R}^2 : |p_1| + |p_2| \leq 1\}, \text{ for } |x| \geq 1, \\ Z(x) &:= \{p = (p_1, p_2) \in \mathbb{R}^2 : |p_1|^{|x|} + |p_2|^{|x|} \leq 1\}, \text{ for } 0 < |x| < 1, \\ Z(0) &:= \left([-1, 1] \times \{0\}\right) \cup \left(\{0\} \times [-1, 1]\right). \end{aligned}$$

As usual we can associate to $Z(\cdot)$ a continuous Hamiltonian function H such that $Z(x)$ are the zero sublevels of $H(x, \cdot)$ for any x . We notice that:

- (1) if $|x| \geq 1$, $Z(x)$ is convex (it is the square with vertices at $(\pm 1, 0)$, $(0, \pm 1)$).
- (2) if $0 \leq |x| < 1$, $Z(x)$ is star-shaped, but not convex, and $K := \text{co}Z(x)$ is the square with vertices at $(\pm 1, 0)$, $(0, \pm 1)$. Such vertices are also the extreme points for $Z(x)$, for any x .
- (3) $Z(x)$ has empty interior iff $x = 0$ (so $\mathcal{E} = \{0\}$).

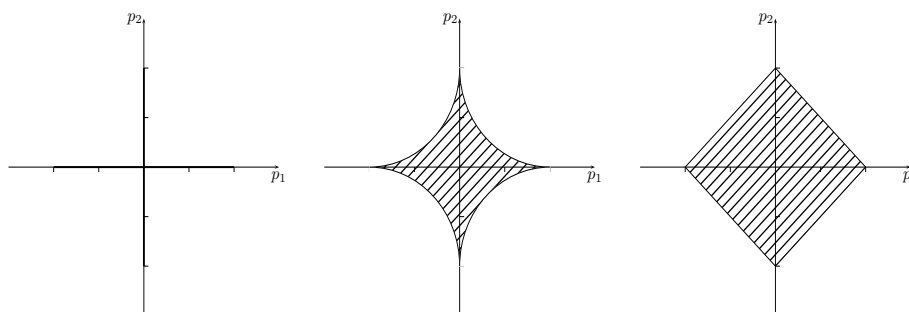

FIGURE 2. $Z(x)$ for $x = 0$, $0 \leq |x| \leq 1$ and $|x| \geq 1$ respectively.

In view of Proposition 3.3, the related metric S is given for any $x = (x_1, x_2), y = (y_1, y_2)$ by

$$S(x, y) = \sigma_K(y - x) = \max\{|y_1 - x_1|, |y_2 - x_2|\},$$

hence S is locally equivalent to the Euclidean metric at all points of \mathbb{R}^2 , moreover S is invariant for translations. We consider the convex function $x \mapsto S_0(x) := S(0, x) = \max\{|x_1|, |x_2|\}$.

We observe the following facts:

- (1) Item (2) in the previous list does not hold: in fact $D^-S_0(0, 0) = \text{co}\{(\pm 1, 0), (0, \pm 1)\}$, which is not contained in $\partial Z(0)$.
- (2) Since $S(x, y) = S(x - y, 0)$, $\partial S_y(y) = \partial S_0(0) = D^-S_0(0, 0) = \text{co}Z(y)$ for every $y \in \mathbb{R}^2$, item (3) fails for $|y| < 1$, since the sublevels are not convex for such points.

Another example is the following:

Example 6.2. We consider the Hamiltonian of Eikonal type $H_f(x, p) = |p| - f(x)$ on \mathbb{R}^n , where the potential f is continuous nonnegative with minimum equal to 0 and $f \leq 1$. For any x , the sublevels $Z_f(x)$ of $H_f = 0$ are the balls centered at 0 with radius $f(x)$. It is clear that 0 is the critical value of H_f since the a -sublevels of H_f become empty, for some x , if $a < 0$ and the null function is a subsolution of $H_f = 0$. As well known, the corresponding Aubry set coincides with the set of minimizers of f , which are, in turn equilibria for H_f , see (2). We denote it by \mathcal{E}_f . Further, we denote by L_f the associated intrinsic critical distance, note that it fails to be equivalent to the Euclidean distance around any minimizer of f , see the item iv. of Proposition 3.1.

We define the family of sets:

$$\tilde{Z}_f(x) := \bigcup_{i=1}^n \{\lambda e_i : \lambda \in [-2, 2]\} \cup Z_f(x),$$

where $\{e_i : i = 1 \dots n\}$ is the canonical basis of \mathbb{R}^n .

We denote by $\tilde{H}_f(x, p)$, \tilde{S}_f an associated Hamiltonian, see Remark 3.1, and the intrinsic nonconvex metric for the equation $\tilde{H}_f = 0$, respectively. Since $\text{int}(\tilde{Z}_f(x)) = \emptyset$ if (and only if) x is a minimizer of f , we see, as before, that 0 is the critical value

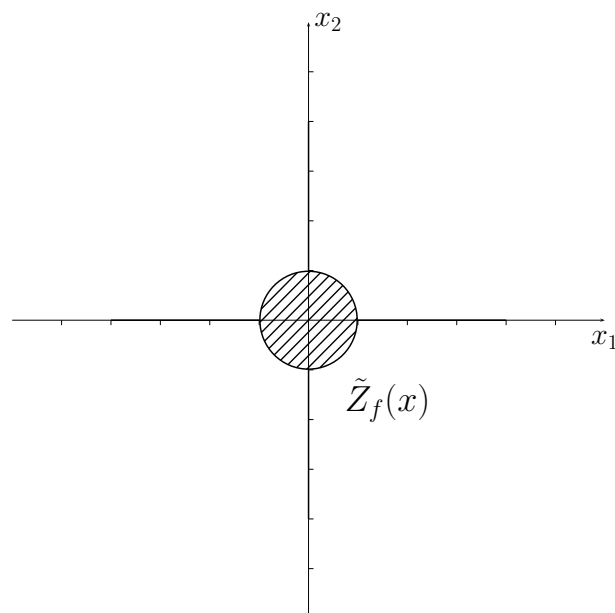
FIGURE 3. $\tilde{Z}_f(x)$

also for \tilde{H}_f . The relevant difference with the convex case is that no peculiar behavior of the metric \tilde{S}_f comes up around such minimizers. In fact the extreme points of the sublevels $\tilde{Z}_f(x)$ does not depend on x , so that $\text{co}(\tilde{Z}_f(x)) = \text{co}\{\pm 2e_i : i = 1 \dots n\} =: K$ is constant. This, in turn, implies that for every pair of points x, y in \mathbb{R}^n

$$\tilde{S}(y, x) = \sigma_K(y - x) = 2 \max\{|x_i - y_i| : i = 1, \dots, n\}.$$

We also point out that there can be infinite different solutions of $\tilde{H}_f = 0$ agreeing on \mathcal{E}_f . To see this, assume

$$(20) \quad \mathcal{E}_f = \{x_n = 0\} \cap \mathbb{R}^n,$$

where $x_n = \langle x, e_n \rangle$. The function

$$u(x) = \min\{L_f(y, x) : y \in \mathcal{E}_f\},$$

is a critical solution for both the equations $H_f = 0$ and $\tilde{H}_f = 0$ since $\partial Z_f(x) \subset \partial \tilde{Z}_f(x)$ for any x , and it takes the value 0 on \mathcal{E}_f . We have $u(x) < |x_n|$ since $0 \leq f \leq 1$. In addition, for $1 < \rho < 2$, the functions $v_\rho(x) = \rho |x_n|$ vanish on \mathcal{E}_f and are also solutions of the nonconvex problem, but not of the convex one. This can be easily checked by direct computation.

REFERENCES

- [1] Martino Bardi and Italo Capuzzo-Dolcetta, *Optimal control and viscosity solutions of Hamilton-Jacobi-Bellman equations*, Systems & Control: Foundations & Applications, Birkhäuser Boston Inc., Boston, MA, 1997. With appendices by Maurizio Falcone and Pierpaolo Soravia. MR1484411 (99e:49001)
- [2] Fabio Camilli and Antonio Siconolfi, *Maximal subsolutions for a class of degenerate Hamilton-Jacobi problems*, Indiana Univ. Math. J. **48** (1999), no. 3, 1111–1131. MR1736967 (2001a:49028)

- [3] Piermarco Cannarsa and Carlo Sinestrari, *Semiconcave functions, Hamilton-Jacobi equations, and optimal control*, Progress in Nonlinear Differential Equations and their Applications, 58, Birkhäuser Boston Inc., Boston, MA, 2004. MR2041617 (2005e:49001)
- [4] P. Cardaliaguet, B. Dacorogna, W. Gangbo, and N. Georgy, *Geometric restrictions for the existence of viscosity solutions*, Ann. Inst. H. Poincaré Anal. Non Linéaire **16** (1999), no. 2, 189–220 (English, with English and French summaries). MR1674769 (99k:35023)
- [5] Frank H. Clarke, *Optimization and nonsmooth analysis*, Canadian Mathematical Society Series of Monographs and Advanced Texts, John Wiley & Sons Inc., New York, 1983. A Wiley-Interscience Publication. MR709590 (85m:49002)
- [6] Bernard Dacorogna and Paolo Marcellini, *Viscosity solutions, almost everywhere solutions and explicit formulas*, Trans. Amer. Math. Soc. **356** (2004), no. 11, 4643–4653 (electronic). MR2067137 (2005c:49064)
- [7] Albert Fathi and Antonio Siconolfi, *PDE aspects of Aubry-Mather theory for quasiconvex Hamiltonians*, Calc. Var. Partial Differential Equations **22** (2005), no. 2, 185–228. MR2106767 (2006f:35023)
- [8] Pierre-Louis Lions, George Papanicolau, and S.R. Srinivasa Varadhan, *Metric character of Hamilton-Jacobi equations*, unpublished preprint (1987).
- [9] R. Tyrrell Rockafellar, *Convex analysis*, Princeton Mathematical Series, No. 28, Princeton University Press, Princeton, N.J., 1970. MR0274683 (43 #445)
- [10] Antonio Siconolfi, *Metric character of Hamilton-Jacobi equations*, Trans. Amer. Math. Soc. **355** (2003), no. 5, 1987–2009 (electronic). MR1953535 (2005k:35043)
- [11] ———, *Errata to: “Metric character of Hamilton-Jacobi equations”* [*Trans. Amer. Math. Soc.* **355** (2003), no. 5, 1987–2009 (electronic); *MR 1953535*], Trans. Amer. Math. Soc. **355** (2003), no. 10, 4265 (electronic). MR1990586 (2005j:35019)
- [12] Sandro Zagatti, *On viscosity solutions of Hamilton-Jacobi equations*, Trans. Amer. Math. Soc. **361** (2009), no. 1, 41–59. MR2439397

ANTONIO MARIGONDA: DIP. DI INFORMATICA, UNIVERSITÀ DI VERONA, STRADA LE GRAZIE 15 - 37134 VERONA, ITALY.

E-mail address: antonio.marigonda@univr.it

ANTONIO SICONOLFI: DIP. DI MATEMATICA “G. CASTELNUOVO”, UNIVERSITÀ “LA SAPIENZA” DI ROMA, P.LE ALDO MORO 2 - 00185 ROMA, ITALY.

E-mail address: siconolf@mat.uniroma1.it