

Electromotive interference in a mechanically oscillating superconductor

FRANÇOIS KONSCHELLE[†] AND YA. M. BLANTER

*Kavli Institute of Nanoscience - Delft University of Technology - Lorentzweg 1 2628 CJ Delft - The Netherlands
October, 7 2011 - [†]Contact: f.konschelle@gmail.com*

PACS 74.25.N- – Superconductivity: Response to electromagnetic fields

PACS 85.25.Dq – Superconducting quantum interference devices (SQUIDs)

PACS 41.60.-m – Radiation by moving charges

PACS 46.40.-f – Vibrations and mechanical waves

Abstract. - We consider the superconducting phase in a moving superconductor and show that it depends on the displacement flux. Generalized constitutive relations between the phase of a superconducting interference device (SQUID) and the position of the oscillating part of its loop are then established. In particular, we show that the Josephson current and voltage depend on both the oscillator position and velocity. The two proposed relativistic corrections to the Josephson relations come from the macroscopic displacement of a quantum condensate according to the (non-)Galilean covariance of the Schrödinger equation, and the kinematic displacement of the quasi-classical interfering path. In particular, we propose an alternative demonstration for the London rotating superconductor effect (also known as the London moment) using the covariance properties of the Schrödinger equation. As an illustration, we show how these electromotive effects may induce self-sustained oscillations of a mechanical system.

Introduction. – The interest to nanomechanical systems dramatically increased recently. Last year, the superposition of quantum states of a mechanical resonator has been demonstrated for the first time [1, 2], realizing an important step towards the generation of mechanically quantum dressed state at the mesoscopic level. These dressed states open wide possibilities for using mechanical resonators for quantum-limited detection and for quantum information. There are currently several routes being explored towards these applications, based on coupling of mechanical resonators to electrical, optical, or magnetic systems. One of the routes, theoretically proposed is to use a mechanical resonator embedded into a superconducting quantum interference device (SQUID), see *e.g.* [3] and references therein. The first experiment demonstrated the possibility of the detection of the resonance frequency and the quality factor of the resonator by measurements of the voltage generated across the SQUID [4]. Magnetic flux through the SQUID and the bias current served as two control parameters. Later experiments [5] investigated back-action of the SQUID exerted on the mechanical resonator and found qualitative agreement with the results of the theoretical modeling.

So far, the description of the experimental setup ignored possible electromotive effects of quantum nature. For instance, it is well known that a cold quantum gas exhibits vortex states under rotation, in a intuitive analogy with the Abrikosov lattice [6]. Nevertheless, the analogy is incorrect, because the Abrikosov lattice is of electromagnetic nature, whereas the circulation vortex lattice is of mechanical origin. A situation when both these effects may compete is precisely the situation when a quantum condensate made of charged particles is mechanically displaced. Then, a superconducting condensate may magnify electromotive effects when put under displacement. This is illustrated by the striking Meissner or London momentum effects [7, 8]. In short, the Meissner effect corresponds to the generation of a displacement current which screens an applied magnetic field, whereas the London momentum effect corresponds to the generation of a macroscopic magnetic field which screens the displacement current generated by the mechanical rotation of a superconductor. This surprising effect can only exist when electromagnetism and mechanical displacement compete together, and can be seen as the destruction of the mechanically induced vortex lattice by the generation of an electromagnetically induced lattice

[9].

Another explanation of this effect lies in the well-known London theory of electrodynamics of superconductors, which corresponds to the addition of an inertial term (proportional to the vector potential $\mathbf{A} \propto \mathbf{j}$) into the otherwise viscous expressions for circuit electromagnetism (*i.e.* Ohm's theory). Because of this inertial correction, the London theory is unable to take into account a change of the inertial frame, in the sense that there is no explicit need to specify in which inertial frame the superconductor is supposed to be. Nevertheless, when a normal metal is attached to a superconducting one, the normal electronic flow must be recovered at the interface. Then, London proposed to correct his theory by imposing a superconducting current to lag behind the lattice one, creating a magnetic moment by virtue of the Ampère law. To test the validity of this retarded contribution, London designed the very simple experiment of the rotating superconductor, which predicts the generation of a macroscopic magnetic field induced by the rotation of a superconducting sphere [7]. The London's prediction was soon after verified for both bulk [10] and proximity effect [11] systems, and latter for high-temperature superconductors [12] including heavy-fermion compounds [13].

More recently, the London expression for the inertial current was considered in the framework of an effective theory of elastic superconductors, with prediction of a precise acoustic sensor using Josephson systems, elastomagnetic coupling between the motion of the superconductor and the internal magnetic moment it produces, in addition to some interesting effects in type-II superconductors, see *e.g.* [14] and references therein. It also continue to attract some fundamental interests, being at the cornerstone of mechanics and electromagnetism [15].

In this paper, we consider some possible electromotive effects of quantum mechanical origin in a moving superconductor. We will concentrate on quasi-classical equations of motion, and first consider the problem of the renormalization of the Josephson relations in a moving superconducting system in general terms. Then, using simple models and arguments, we will derive constitutive relations linking the oscillator motion to the current and voltage, and propose an alternative demonstration for the London momentum effect based on the covariance of the Schrödinger equation. Subsequently, we apply the arguments to the setup of a suspended SQUID. We believe, however, that much of this work can be adapted to other detection schemes, especially those using superconducting cavities [16] or cold quantum gases [17]. As a simple illustration of the theory, we will describe the regime when a static current can induce self-sustained oscillations of the nanoscale bar embedded into the superconducting loop.

Model of a suspended SQUID. – Our starting point is the setup shown in Fig.1.a which consists of a superconducting loop with two Josephson junctions, coupled to a mechanical harmonic oscillator. The SQUID is

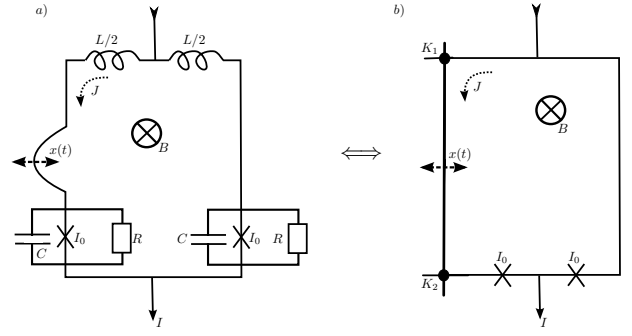

Fig. 1: The scheme of a nanomechanical oscillator embedded into a SQUID circuit. The assumption of this work is to consider the scheme a) as being equivalent to the scheme b) (for representation simplicity, we drop the self-inductance L , capacitance C and resistance R on the b) subfigure). In particular, this assumption allows us to disregard the elastic properties of the bar, and to use relativistic arguments when the bar and circuit are two different sub-systems of the entire circuit.

characterized by two degrees of freedom, which we take to be the sum and the difference of the phases of the junctions, respectively, φ_{\pm} . The equations of motion can be easily written in the quasi-classical approximation,

$$\begin{cases} i = \sin \varphi_+ \cos \varphi_- + \omega_c^{-1} \dot{\varphi}_+ + (RC/\omega_c) \ddot{\varphi}_+ \\ j = \sin \varphi_- \cos \varphi_+ + \omega_c^{-1} \dot{\varphi}_- + (RC/\omega_c) \ddot{\varphi}_- \end{cases} \quad (1)$$

with $\omega_c = 2\pi RI_0/\Phi_0$ the characteristic frequency of the SQUID, I_0 the critical current of each Josephson junction, $\Phi_0 = \pi\hbar/e$ the superconducting flux quantum, R and C the resistance and capacitance of the shunted Josephson junctions, $i = I/2I_0$ and $j = J/2I_0$, where I and J are the bias and self-circulating current, respectively [18]. The overdot refers to global time derivative.

When one arm of the superconducting loop is oscillating (see Fig.1.a), Eqs.(1) are supplemented by the equation of motion for the resonator with the mass m , the length ℓ , the quality factor Q , and the resonance frequency ω_0 according to

$$\ddot{x} + \frac{\omega_0}{Q} \dot{x} + \omega_0^2 x = g(i + j) \quad (2)$$

where $g \approx \ell BI_0/m$ is a geometric acceleration, such that $g(i + j)$ represents the Lorentz force when B is the external magnetic field. Usually, the SQUID and oscillator dynamics are coupled through constitutive relations for the phase difference and the phase sum [3–5, 18]

$$\varphi_- = -\varphi_e - \kappa_- x - \beta j \text{ and } \dot{\varphi}_+ = \frac{\Phi_0}{2\pi} V, \quad (3)$$

where $\beta = 4\pi LI_0/\Phi_0$ is the self-inductance of the loop, $\kappa_- \approx \pi B\ell/\Phi_0$ is the flux-to-phase geometric coupling,

$\varphi_e = \pi\Phi/\Phi_0$, Φ the external flux across the loop. The phase sum-voltage relation has been used to obtain the system (1) in a quasi-classical way.

Let us shortly address an illustrating situation in the static case. Taking $\beta = 0$ for simplicity, the phase difference φ_- degree of freedom is frozen by the mechanical displacement, and the dimensionless static potential of the above situation is

$$u(\varphi_+, x) = 1 - \cos \varphi_+ \cos(\varphi_e + \kappa x) + i\varphi_+ + \omega^2 x^2/2 \quad (4)$$

where $\omega^2 = m\omega_0^2/E_J$ is the rescaled frequency, and E_J is the Josephson energy. The minima of the potential (4) correspond to the possibility for the global system to be in a fluxon state corresponding to a given amplitude of the mechanical bar. Then, it becomes possible to change the amplitude of the mechanical deformation *and* the fluxon state by the application of the current i or the magnetic flux φ_e , and *vice-versa*. In other words, when a mechanical arm of the SQUID loop is able to move, the position x degree of freedom is able to affect the magnetic degree of freedom of the entire SQUID. Reciprocally, a change in the fluxon state of the SQUID can change the equilibrium amplitude of the mechanical arm. The amplitude degree of freedom is thus formally identical to an electromagnetic degree of freedom.

Alternatively, Eq. (2), when seen as the equation of motion for the x degree of freedom of the circuit, can be interpreted as the harmonic generation of electromagnetic field. Moreover, it is well known that electromagnetism is such defined that *both position x and velocity \dot{x}* play the role of sources [19]. The following discussion aims at introducing velocity dependencies into the constitutive relations (3) and the equations of motion (1) in order to overcome the conceptual difficulties of dealing with mechanical displacement and electromagnetism in superconducting circuitry. Our subsequent reasoning will transform Eqs.(1) and (3) into Eqs.(14) and (15).

In order to find the electromotive contributions, we assume that the elastic scheme described in Fig.1.a can be made formally identical to the one depicted on Fig.1.b. In this way, we transform the elastic bar into a rigid one, which can move harmonically on top of the remaining circuit. This assumption transforms the previous complicated situation into a simpler one, quite familiar when discussing electromotive effects in term of classical electromagnetism [19]. In particular, this model allows us to make the following assumptions,

- (i) The oscillator displacement function $x(t)$ is a function of the *time only*.
- (ii) The two systems of the oscillating bar and the remaining circuit are *relativistically separable*.

These two assumptions are crucial for the following discussion. Clearly, without the first assumption, the displacement function would be a true field dependent on

both position and time, which requires a complete description in term of quasi-classical elasto-electro-magnetism. This rather complicated situation is out of the scope of the present study. Thus, assumption (i) allows us to disregard some possible elastic ambiguities of the problem. The second assumption is just a convenient one in order to verify that the forthcoming electromotive terms can be justified on the basis of Galilean relativity, eventually complemented by non-inertial effects. In particular, assumption (ii) allows us to attach an inertial frame of reference to the circuit at rest, and a non-inertial frame to the oscillating bar.

In order to complete the circuit, the contact points K_1 and K_2 on Fig.1.b are assumed to be frictionless, and electrical contacts are taken to be ideal.

Electromotive contributions. – Equations (1) and (3) do not take into account the specific properties of a moving superconductor, which are expressed as relativistic contributions to the phase-flux and phase-voltage constitutive relations (3). In order to obtain these contributions, we constraint the phase of the superconducting, macroscopic wave function to be continuous all around the circuit loop. When the loop is pierced by a magnetic flux $\Phi = \oint \mathbf{A} \cdot d\mathbf{l}$, the phase continuity imposes to consider the so-called gauge covariant phase $\gamma = \varphi_0 - 2\pi\Phi/\Phi_0$, where φ_0 is the initial condition phase [18].

In the situation depicted in Fig.1.b, this gauge covariant phase fails to describe the passage from the circuit at rest to the moving bar. Indeed, γ is the gauge covariant phase for circuits at rest. From general properties of quantum mechanics, the displacement of a particle in space imposes to add phase factors to the wave function. For a massive particle associated with this wave function, the two possible phase factors correspond to the energy correction $e^{iEt/\hbar} \sim e^{imv^2t/2\hbar}$ due to the kinetic energy the particle acquires under displacement ; and the displacement operator of the wave function $e^{ipx/\hbar} \sim e^{imvx/\hbar}$. We thus see from these simple arguments that a full covariant phase may include some velocity dependencies.

Let us quantify this idea. To obtain the complete phase transformation, we will use the covariance properties of the Schrödinger equation under a non-inertial transformation defined by $\mathbf{x}' = \mathbf{x} - \mathbf{r}(t)$ and $t' = t$. Then, the differential operators appearing in the Schrödinger equation transform according to $\partial/\partial t' = \partial/\partial t + \mathbf{v}(t) \cdot \nabla$ and $\nabla' = \nabla$ where $\mathbf{v}(t) = \dot{\mathbf{r}}$ is time dependent. Moreover, one can show that the Schrödinger equation for particle of mass m and charge q ,

$$i\hbar \frac{\partial \Psi}{\partial t} = \left[U + qV - \frac{\hbar^2}{2m} \left(\nabla - i\frac{q}{\hbar} \mathbf{A} \right)^2 \right] \Psi(\mathbf{x}, t), \quad (5)$$

is formally equivalent to the one with electromagnetic potentials V and \mathbf{A} , potential U and wave function Ψ expressed in the displaced (primed) system with the corre-

spondence laws

$$\begin{cases} U'(\mathbf{x}', t') = U(\mathbf{x}, t) + m\dot{\mathbf{v}}(t) \\ V'(\mathbf{x}', t') = V(\mathbf{x}, t) - \mathbf{v} \cdot \mathbf{A}(\mathbf{x}, t) \\ \mathbf{A}'(\mathbf{x}', t') = \mathbf{A}(\mathbf{x}, t) \end{cases} \quad (6)$$

for displaced potentials and

$$\Psi'(\mathbf{x}', t') = \exp \left[\frac{i}{\hbar} \left(\int_{t_0}^t \frac{mv^2}{2} dt - m\mathbf{v} \cdot \mathbf{x} \right) \right] \Psi(\mathbf{x}, t) \quad (7)$$

for the wave function (t_0 being the initial time when $\mathbf{v}(t_0) = \mathbf{0}$). The simplest case of the Galilean transformation [20] with $\dot{\mathbf{v}} = \mathbf{0}$ is the obvious limit $\Psi' = \exp[i(\mathbf{E}t - \mathbf{p} \cdot \mathbf{x})/\hbar] \Psi$ of the transformation (6)-(7) (In short: Galilean relativity constraints the free particle to generate plane waves under displacement). However, for treating oscillations we need to consider non-inertial transformations. Note that the covariance of the Schrödinger equation would be destroyed if \mathbf{r} were a function of both time and position, because of the appearance of mixing derivatives [21]. The assumption (i) above is needed to keep the covariance.

The meaning of the above transformation is clear. When a part of a circuit is moving as in Fig.1.b, we have two choices. We can either solve the Schrödinger equation in the moving frame and to select solutions which satisfy the condition of the phase continuity. Alternatively, we can transform the equation to the rest frame. In the latter case, the phase continuity requirement follows from the redefinition (7) of the wave function in the displaced region. Because the same argument holds with the vector potential – we once again have the choice to calculate the solution when the covariant term \mathbf{A} is included in the Schrödinger equation and the solution must explicitly verify phase continuity after all, or we can simply use the gauge covariant phase γ which guarantees the phase continuity everywhere – the complete gauge covariant phase will be

$$\varphi = \varphi_0 - \frac{2\pi}{\Phi_0} \oint \mathbf{A} \cdot d\mathbf{l} + \frac{2\pi m_e}{\Phi_0 e} \oint \mathbf{v} \cdot d\mathbf{l} \quad (8)$$

where $2m_e$ is the Cooper pair mass. Obviously, the velocity integral in Eq. (8) disappears when the superconducting condensate remains at rest along the phase path, and thus it connects the displacement velocity to the phase difference in the Josephson system and eventually to the Josephson current. Note that the electromotive term does not require magnetic field. Thus, even a single Josephson junction, or a bulk superconductor, may exhibit such an electromotive effect (see [14, 15] for more references).

The inclusion of the relativistic correction in (8) suggests that some subsequent contributions will be found for its time derivative. Indeed, the second Josephson relation connects the time derivative of the superconducting phase with the energy difference across the weak-links, *i.e.* to the electromagnetic work the superconducting charges undergo when travelling across the junction. The total

electromagnetic work is found according to the complete Lorentz force. One obtains

$$\frac{d\varphi}{dt} = \frac{2\pi m_e}{\Phi_0 e} \frac{d}{dt} \oint \mathbf{v} \cdot d\mathbf{l} + \frac{2\pi}{\Phi_0} \oint (\mathbf{E} + \mathbf{v} \times \mathbf{B}) \cdot d\mathbf{l} \quad (9)$$

for the phase-voltage relation. For $\mathbf{v} = \mathbf{0}$, we obviously recover the (second) Josephson relation $\dot{\varphi} = 2eV/\hbar$. In addition to the first term, which generates electromagnetic fields due to the motion of accelerating charges, the last term in Eq. (9) is another electromotive one, caused by the moving surface the magnetic flux threads. Thus, even a static magnetic field can generate such a retarded effect, because it is due to the kinematic displacement of the interfering paths in the presence of an electromagnetic field. Indeed, in Ref. [22], it is demonstrated that (for any \mathbf{B} and \mathbf{S} fields)

$$\frac{d}{dt} \iint \mathbf{B} \cdot d\mathbf{S} = \iint \left[\frac{\partial \mathbf{B}}{\partial t} - \nabla \times \mathbf{v} \times \mathbf{B} + \mathbf{v} (\nabla \cdot \mathbf{B}) \right] \cdot d\mathbf{S} \quad (10)$$

when the infinitesimal surface element $d\mathbf{S}$ is time dependent, with $\mathbf{v}(t)$ the velocity field of the contour. From Eq.(8), Eq.(10) reduces to Eq.(9) using Faraday's law. The two expressions (8) and (9) and their explicit derivations are the main results of this Letter. We believe that they are rather general, because the notation $\varphi = \int \nabla \varphi \cdot d\mathbf{l}$ above was a generic phase difference along a superconducting path, eventually closed. In particular, it was neither φ_+ nor φ_- used for the specific example of the SQUID discussed otherwise.

The equations (8) and (9) representing the electromotive contributions to the constitutive relations provide the description of the combined mechanical plus superconducting systems. It is not immediately clear for us whether these relations can be easily reproduced starting from the phonon concepts, or more generally from microscopic models of superconductivity (see *e.g.* [8]).

Let us now make some remarks about our above derivation. From the transformation law (7), it is easy to show that the electromagnetic sources $\rho = q|\Psi|^2$ and $\mathbf{j} = q\hbar \text{Im}\{\Psi^* \nabla \Psi\}/m$ transform as (cf. [20])

$$\begin{cases} \rho'(\mathbf{x}', t') = \rho(\mathbf{x}, t) \\ \mathbf{j}'(\mathbf{x}', t') = \mathbf{j}(\mathbf{x}, t) - \rho(\mathbf{x}, t) \mathbf{v}(t) \end{cases} \quad (11)$$

Here, the transformation law for the current is nothing else than the London current substitution when a superconductor is displaced [7]. We have thus shown that the London current substitution can be demonstrated using the covariance of the Schrödinger equation. We even found that the London current is still a correct expression for non-inertial displacements. Note that our argument is just the quantum version of the London's original one, because phase continuity and current conservation are related to each other.

Note also that Eqs.(8) and (6) are presumably invalid for a true velocity field $\mathbf{v}(\mathbf{x}, t)$. In particular, our assumption

(i) was crucial to obtain the London expression for the current (recall that \mathbf{j} is defined as a gradient interference). We also note that the full transformations (6), (7) and (11) are compatible with the usual electromagnetic gauge transformations, and that the space-time transformation laws for the electromagnetic potentials (and subsequently for the electromagnetic fields) correspond to the *magnetic-Galilean-limit* when the electric displacement current does not exist, see [20, 23] and note [24].

Modification of the constitutive relations of the SQUID. – We now return to the main discussion and include the electromotive contributions (8) and (9) into the specific equations describing the SQUID dynamics.

Usually, the velocity integral term in Eq.(8) is transformed to the flux of $\nabla \times \mathbf{v}$, then restoring the usual London electromotive effect in term of Josephson current [15]. In our case, the integration contour $\mathbf{l}(t)$ is made of the moving bar itself, and thus depends on time as the mechanical parts are moving. Using assumption (i), we write $\int \mathbf{v} \cdot d\mathbf{l} \approx \int (d\mathbf{l})^2 / dt$. The integral then reduces to the two contact points $K_{1,2}$ on Fig.1.b and can be approximated by $\ell \dot{x}$. Note this is also the rate of surface motion of the circuit, or, in our simple geometry, the rate of the length path variation. In other words, when a superconducting path is moving, the superconducting phase behaves according to the *static and kinematic* properties of the displacement.

In our SQUID setup, the phase difference thus reads

$$\varphi_- = -\varphi_e - \kappa_- x + \frac{k}{\omega_0} \dot{x}, \quad (12)$$

with $k \approx (m_e \omega_0 / \hbar) \ell$ within our approximation. This equation generalizes Eq.(3).

Note that k is the inverse of an effective Compton wavelength [11], related to the inertia of the electrons because of their lag behind the lattice mechanical oscillations. Seen as a relativistic correction, the k term in (12) can be interpreted as an angular momentum-orbit interaction, in full analogy with spin-orbit effects into Josephson physics [25]. The main difference between the spin-orbit and the angular momentum-orbit interactions is just the chosen frame of reference. Indeed, the spin-orbit effect is due to the change of frame between the moving electron and the nucleus at rest in an atom, whereas the angular momentum-orbit interaction comes from the change of frame between the superconducting charges at rest and the ionic lattice which moves with the mechanical vibrations. It is then obvious that the mechanical vibrations, like any motion of a superconductor, can be seen as the generation of an internal angular momentum, which may eventually lead to macroscopic magnetic field correction.

Comparing the two oscillating contributions in (12) leads to the ratio $B/\omega_0 \approx m_e/2e \approx 3\text{ng}/C$ which is very small, thus explaining why such a relativistic contribution has not been found in previous experiments [4, 5]. Nevertheless, being a velocity term, the Compton contribution has to be compared with the Q -factor of the oscillator,

which may eventually be large enough to make interesting relativistic effects observable at the nanoscale. Also, it is interesting to mention that the k term in (12) survives in the absence of magnetic field. Thus, the observation of this electromotive effect in the absence of external magnetic field will be a clear demonstration that a displacement of charges generates a complete electromagnetic field at the quantum level.

In a SQUID, the phase difference is not affected by the contribution (9), and the $\mathbf{v} \times \mathbf{B}$ term affects only the phase sum φ_+ . Eq.(9) implies that the voltage is defined in the following way,

$$V = \frac{\Phi_0}{2\pi} \frac{d}{dt} \left[\varphi_+ + \kappa_+ x - \frac{k}{\omega_0} \dot{x} \right] \quad (13)$$

with $\kappa_+ \approx \kappa_- \approx \pi B \ell / \Phi_0$ in our approximation. This expression appears natural: because the position of the oscillating bar is equivalent to a flux for the SQUID, its velocity \dot{x} generates voltage. The Compton k -term plays the role of usual Bremsstrahlung in (13).

Finally, the above discussions can be summed up in the system of equations

$$\begin{cases} i = \sin \varphi_+ \cos \varphi_- + \frac{\dot{\varphi}_+ + \kappa_+ \dot{x} - k \ddot{x} / \omega_0}{\omega_c} \\ \quad + \frac{RC}{\omega_c} \left(\ddot{\varphi}_+ + \kappa_+ \ddot{x} - \frac{k}{\omega_0} \ddot{\ddot{x}} \right) \\ j = \sin \varphi_- \cos \varphi_+ + \frac{\dot{\varphi}_-}{\omega_c} + \frac{RC}{\omega_c} \ddot{\varphi}_- \end{cases} \quad (14)$$

and the constitutive relations

$$\begin{cases} \varphi_- = -\varphi_e - \kappa_- x + k \dot{x} / \omega_0 - \beta j \\ \dot{\varphi}_+ = 2\pi V / \Phi_0 - \kappa_+ \dot{x} + k \ddot{x} / \omega_0 \end{cases} \quad (15)$$

which represent the coupled dynamics of a SQUID with an embedded mechanical resonator. The motion of the resonator $x(t)$ is governed by Eq.(2).

Self-sustained oscillations. – Now we discuss generation of self-sustained oscillations by static current.

In the overdamped limit and without self inductance (*i.e.* $RC/\omega_c \rightarrow 0$ and $\beta \rightarrow 0$), the macroscopic time averaged voltage can be approximated as [18]

$$\frac{\langle V \rangle}{RI_0} = \sqrt{\left(\frac{I}{2I_0} \right)^2 - \cos^2 \left(\varphi_e + \kappa_- x - \frac{k}{\omega_0} \dot{x} \right)} \quad (16)$$

in the limit $\omega_0/\omega_c \ll 1$ (this limit is the correct one for actual experiments [4, 5], when $\omega_0/\omega_c \lesssim (10^{-3} - 10^{-4})$). Then, in the oscillating bar equation of motion (2), one has to realize that the Lorentz force is present only in the resistive branch of the SQUID response, and Eq.(2) can be approximated as

$$\ddot{x} + \frac{\omega_0}{Q} \dot{x} + \omega_0^2 x = g \frac{\langle V \rangle}{RI_0} \quad (17)$$

which exhibits self-sustained oscillations when $gk/RI_0\omega_0^2 \gtrsim Q^{-1}$. Thus, to apply a static current

to a SQUID may generate self-sustained oscillations of a mechanical mesoscopic device. This striking effect can be observed with longer oscillators than those currently used (recall that $gk \propto \ell^2$), or with higher Q -factors. Note that the self-sustained oscillations described in (17) originate from the Compton term k . Thus, the presence of self-sustained oscillations is independent of the presence of the external magnetic flux.

Conclusion. — In comparison with the initial equations of motion (1)-(3), we have thus established and discussed two different kinds of electromotive effects corresponding to the terms κ_+ and k in the systems (14) and (15). These electromotive effects may be relevant for the description of the measurement process of a quasi-classic elastic bar motion, and/or for the description of the back-action effects a SQUID exerts on an embedded mechanical oscillator. More precisely, the Compton-like k term seems to be important for backaction effect, because it generates magnetic flux ; whereas the kinetic interference κ_+ term transforms existing magnetic field into voltage, and might be important for detection purpose when the voltage is monitored.

We demonstrate that under certain conditions, the electromotive effects can lead to the development of self-sustained oscillations in the suspended SQUID geometry. This is, however, not the only explanation: Capacitive effects may be responsible as well for self-sustained oscillations, without requiring an explicit velocity dependent phase-flux relation (*i.e.* in the limit $k\dot{x}/\omega_0 \rightarrow 0$ and $\kappa_+x \rightarrow 0$ in (15) but with a finite RC/ω_c term for which $i = \langle V \rangle / RI_0 + Cd \langle V \rangle / I_0 dt$ with the Eq.(16) as a trial expression for $\langle V \rangle$ and with $k \rightarrow 0$). One possible way to distinguish between these two electromagnetic contributions is to consider vanishing magnetic field, see [26] for more details.

In order to find the relativistic contributions, we assumed that it is formally possible to separate the two subsystems, and use some relativistic (*i.e.* covariance) arguments of their quantum properties. In addition, we believe that such electromotive contributions are difficult to obtain using phonon models, which opens the question of appropriate arguments to describe elasticity and mechanics at a mesoscopic length scale, in particular the inclusion of mechanical systems into electromagnetic ones. Testing our conclusions beyond these assumptions goes beyond the scope of this paper.

* * *

We thank R.P. TIWARI, I. BOUCHOLE and D. DULIN for stimulating discussions, S. ETAKI and H.S.J. VAN DER ZANT for discussing their results prior to their publications, and B. BERGERET for bibliographic facilities. We acknowledge the financial support of the Future and Emerging Technologies program of the European Commission, under the FET-Open project QNEMS (233992) and

of the Netherlands Foundation for Fundamental Research on Matter (FOM).

REFERENCES

- [1] O'CONNELL A. D. *et al.*, *Nature*, **464** (2010) 697.
- [2] TEUFEL J. D. *et al.*, *Nature Nanotechnology*, **4** (2009) 820.
- [3] ZHOU, X. and MIZEL, A., *Phys. Rev. Lett.*, **97** (2006) 267201. BUKS E. and BLENCOWE M. P., *Phys. Rev. B*, **74** (2006) 174504. NATION P., BLENCOWE M. P. and BUKS E., *Phys. Rev. B*, **78** (2008) 104516. PUGNETTI S., BLANTER Y. M. and FAZIO R., *Europhys. Lett.*, **90** (2010) 48007.
- [4] ETAKI S. *et al.*, *Nature Physics*, **4** (2008) 785.
- [5] POOT M. *et al.*, *Phys. Rev. Lett.*, **105** (2010) 207203.
- [6] BLOCH I., DALIBARD J. and ZWERGER W., *Rev. Mod. Phys.*, **80** (2007) 885
- [7] LONDON F., *Superfluids, volume I: Macroscopic theory of superconductivity* 2nd Edition (Dover Publications, Inc.) 1961.
- [8] HIRSCH J. E., *Phys. Lett. A*, **315** (2003) 474.
- [9] BOUCHOLE I., *Personal communication*.
- [10] HILDEBRANDT A., *Phys. Rev. Lett.*, **12** (1964) 190.
- [11] ZIMMERMAN J. and MERCEREAU J., *Phys. Rev. Lett.*, **14** (1965) 887.
- [12] VERHELJEN A. A., VAN RUITENBEEK J. M., DE BRUYN OUBOTER R. and DE JONGH L. J., *Nature*, **345** (1990) 418.
- [13] SANZARI M. A., CUI H. L. and KARWACKI F., *Applied Phys. Lett.*, **68** (1996) 3802.
- [14] ZHOU S.-A., *Int. J. Eng. Science*, **36** (1998) 1511.
- [15] FISCHER U., HÄUSSLER C., OPPENLÄNDER J. and SCHOPOHL N., *Phys. Rev. B*, **64** (2001) 214509.
- [16] REGAL C. A., TEUFEL J. D. and LEHNERT K. W., *Nature Physics*, **4** (2008) 555.
- [17] CAMERER S. *et al.*, *arXiv*, **1107.3650** (2011) unpublished.
- [18] TINKHAM M., *Introduction to superconductivity* 2nd Edition (Dover Publications, Inc) 1996.
- [19] FEYNMAN R. P., LEIGHTON R. B. and SANDS M., *The Feynman lectures on physics. Volume II, Mainly electromagnetism and matter* (Addison Wesley) 1964.
- [20] BROWN H. R. and HOLLAND P., *Am. J. of Phys.*, **67** (1999) 204.
- [21] TAKAGI S., *Progress Theor. Phys.*, **85** (1991) 463.
- [22] FLANDERS H., *The Am. Math. Monthly*, **80** (1973) 615.
- [23] LE BELLAC M. and LÉVY-LEBLOND J.-M., *Il Nuovo Cimento B*, **14** (1973) 217.
- [24] In the so-called magnetic limit, the Galilean-covariant equations of electromagnetic fields \mathbf{E} and \mathbf{B} are the usual ones $\partial\mathbf{B}/\partial t + \nabla \times \mathbf{E} = \mathbf{0}$ and $\nabla \cdot \mathbf{B} = 0$, whereas the \mathbf{H} and \mathbf{D} fields fail to verify the charge conservation: $\nabla \times \mathbf{H} = \mathbf{j}$ and $\nabla \cdot \mathbf{D} = \rho$. Nevertheless, one still verifies $\mathbf{B} = \nabla \times \mathbf{A}$ and $\mathbf{E} = -\nabla V - \partial\mathbf{A}/\partial t$, which guaranty gauge invariance of the fields. Injecting $\tilde{\mathbf{A}} = \mathbf{A} + \nabla\xi$ and $\tilde{V} = V + \partial\xi/\partial t$ for any ξ function in (6) will not modify the covariance of the potentials transformation laws: then the covariance laws (6) and the gauge invariance of the fields are compatible. See [20] and reference therein for more details.

- [25] BUZDIN A. I., *Phys. Rev. Lett.*, **101** (2008) 107005.
REYNOSO A. *et al.*, *Phys. Rev. Lett.*, **101** (2008) 107001.
ZAZUNOV A., EGGER R., JONCKHEERE T. and MARTIN
T., *Phys. Rev. Lett.*, **103** (2009) 147004.
- [26] ETAKI S., KONSHELLE F., BLANTER YA. M. and VAN
DER ZANT H. S. J., *In preparation*.