

Heating control schemes for energy management in buildings

Benjamin Paris, Julien Eynard, Stéphane Grieu, Thierry Talbert and Monique Polit

*ELIAUS Lab., University of Perpignan Via Domitia, 52 Av. Paul Alduy, 66860, Perpignan, France
{benjamin.paris; julien.eynard; grieu; talbert; polit}@univ-perp.fr*

Abstract: because of both the global energy crisis and the necessary improvement of energy efficiency in buildings, one of the largest sectors of energy consumption and greenhouse gases emissions, a strategy allowing managing energy resources is proposed. Its aim is reducing energy consumption and promoting the use of renewable energy, while ensuring thermal comfort, when heating "multi-energy" buildings, thanks to indoor temperature control schemes. Three schemes (based on a commonly-used PID controller and on the combination of PID and model predictive or fuzzy controllers) were tested in simulation, using dynamic models describing the thermal behavior of a building, and fully met the management strategy's requirements, especially reducing the consumption of fossil energy. Three criteria describing the way energy is used and controlled in real-time were defined with the aim of evaluating the control schemes performance and adapting the strategy to the specific use of a building. The PID-MPC provided the best results while the PID-FLC proved to be a very good compromise, thanks to both the flexibility and the adaptability offered by fuzzy logic, between the easy-to-develop but not-very-efficient PID and the efficient but hard-to-develop PID-MPC.

Keywords: multi-energy buildings, energy management strategy, heating, PID, Model Predictive Control (MPC), Fuzzy Logic Control (FLC).

1. Introduction

The European energy context reveals that the building, industry and transport sectors are the three largest sectors of energy consumption. As a consequence, the Directive "Energy Performance of Building" (EPBD) [1], focusing on energy use in buildings and urging the members of the European Union (EU) of improving energy efficiency, has been adopted. In France, where 25% of greenhouse gases emissions and 46% of energy consumption [2] are due to buildings, both the "Thermal Regulation 2005" [3] and the "Energy Performance Diagnosis" [4] are in agreement with the just-mentioned Directive's recommendation and are more and more rigorous about energy performance. Usually, the building's Energy Performance Indicator (EPI) is calculated to classify buildings [3,4]. Unfortunately, this global indicator expresses the amount of energy consumption only, without any explanation. It does not dissociate the various energy consumption components and does not explain how energy is consumed in buildings. As a consequence, proposing efficient control approaches (as well as new evaluation criteria) allowing ensuring thermal comfort, while reducing significantly energy consumption, has become mandatory.

Taking a look at the state of the art about energy in buildings [5], one can highlight the way this theme is handled by researchers. Mathews et al. (2008) [6], Levermore et al. (1992) [7], Bernard et al. (1982) [8], Kolokotsa et al. (2005) [9], Ben-Nakhi et al. (2001) [10], Kalogirou et al. (2000) [11] and Gonzalez et al. (2005) [12] presented works related to energy management, cost strategies and energy consumption forecast, while Chen et al. (2006) [13], Calvino et al. (2004) [14], Kummert et al. (2001) [15], Morel et al. (2000) [16], Nygard (1990) [17], Lute et al. (2000) [18], Liang et al. (2005) [19] and Argiriou et al. (2001) [20] focus on fuzzy, neural network, optimal or predictive control of thermal conditions in buildings. However, energy management in buildings is not really correlated with energy savings and clear strategies to optimize the use of several (fossil and renewable) energy resources are not defined. Moreover, these works are often devoted to the specific use of a given building. That is why the present work deals with an efficient and widely-adaptable strategy allowing managing fossil and renewable energy resources in buildings (one speaks of "multi-energy" buildings). Indoor temperature control schemes were developed with the aim of both favoring energy savings and increasing the renewable energy contribution, while ensuring thermal comfort. Because of its significant impact on energy consumption, heating is the key-point. As a consequence, advanced indoor temperature control schemes allowing managing (fossil and renewable) energy resources are proposed. Moreover, and because PID controllers are

commonly used in buildings engineering, the advanced control schemes proposed are built on the basis of a PID controller (let us note that the performance of this controller was considered as "reference" performance). This allows implementing these schemes in buildings even if a control system based on such a controller is already in use and improving its performance. First, a PID-MPC (Model Predictive Control) control scheme is proposed, as the combination of PID and MPC controllers. Model predictive controllers can inherently handle constraints. Such controllers are model-based and discrete controllers allowing calculating an optimal command sequence and anticipating set-point changes. Moreover, and with the aim of easily taking into account expert knowledge about thermal comfort and energy management in multi-energy buildings, a PID-FLC (Fuzzy Logic Control) control scheme is also proposed, as the combination of PID and fuzzy controllers. Let us note that a building mock-up has been built, instrumented and modeled to test the proposed control schemes. Instrumentation consists of height temperature sensors and two resistors used as heat sources. Finally, criteria (about fossil energy consumption, thermal comfort and control performance) describing the way energy is used and controlled in real-time were defined with the aim of evaluating both the energy management strategy proposed and the control schemes (PID, PID-MPC and PID-FLC).

2. Energy management strategy

2.1. Strategy fundamentals

Reviewing both the "Thermal Regulation 2005" and the "Energy Performance Diagnosis" while taking into consideration the main objective of the French government, dealing with a significant reduction of fossil energy consumption in buildings, allowed defining the fundamentals of the proposed strategy. First, one can define various energy consumption components, such as heating and cooling, water heating, lighting, cooking, ventilation or electronics. One can highlight, and this is a key-point, that the majority of energy consumed is for heating (largely dependent on outside temperatures), which account for about 60% of all delivered energy consumed in buildings. As a consequence, the proposed strategy focuses on managing heating systems, considering multi-energy buildings. On another hand, the just-mentioned documentation indicates, first, the way an energy performance diagnosis can be carried out (via the characterization of the building materials used, analyzing thermal insulation properties or investigating the influence on energy consumption of the building's localization) and, secondly, recommends considering buildings through a systemic approach (one speaks of multi-area buildings). Moreover, it highlight the use of a building (offices, dwellings, public buildings...) as one of the key points when trying to evaluate the energy impact of buildings. Consequently, we want the proposed strategy to be easily and widely adaptable to the specific use of a building. As most of the thermal regulations used in the world to classify buildings from their energy performance, the French "Thermal Regulation 2005" is based on the building's Energy Performance Indicator ($\text{kWh}\cdot\text{m}^{-2}\cdot\text{year}^{-1}$). As previously mentioned, this global indicator expresses the amount of energy consumption only, without explaining how energy is consumed. So, as a part of the proposed strategy, new and useful criteria, dealing with thermal comfort, fossil energy consumption and global performance, were defined (section 2.2). Although renewable energy supply is increasing continuously, supply systems are often controlled in an inadequate way, or taking no account of all the available energy resources. Ensuring thermal comfort is also essential because of its psychological implications. In some cases, people may refuse to live or to work in a particular environment. That is why the proposed strategy deals with optimizing energy performance and promoting renewable energy, while ensuring thermal comfort, in multi-energy buildings (with both fossil and renewable energy resources), using indoor temperature controllers.

2.2. Criteria for evaluating the control schemes performance

Tools are needed for comparing the controllers' performance. As previously mentioned, the building's EPI only provides partial information. That is why additional criteria, $\%_{FE}$ (criterion to be minimized) and both comfort (I_C) and performance (I_P) criteria (criteria to be maximized), were developed. These criteria incorporate the way energy is in real-time used and controlled. Let us note that common criteria for human feeling in heated rooms or buildings such as both "Predictive Mean Vote" and "Percentage of Dissatisfied" criteria [21], are found in the literature but do not match with the objectives. First, the criterion $\%_{FE}$ is defined as the percentage of the fossil energy

consumed compared with the total energy used. Then, the comfort criterion I_C , based on temperature set-point tracking, specifies the mean relative error between T_{SP} (°C) and T_m (°C). Finally, the criterion I_P focuses on both the performance of the proposed controller, comparing the two just-mentioned criteria, and the way the control scheme impacts energy consumption (Equation 1).

$$\%_{FE} = 100 \times \frac{E_{FE}}{E_{TOT}} ; I_C = 100 \times \left(1 - \frac{\|T_{SP} - T_m\|_2}{\|T_{SP} - \langle T_{SP} \rangle\|_2} \right) ; I_P = (I_C - \%_{FE}) \quad [Eq. 1]$$

E_{FE}	<i>Fossil energy consumed</i>	$kWh.m^{-2}.year^{-1}$
E_{RE}	<i>Renewable energy consumed</i>	$kWh.m^{-2}.year^{-1}$
$E_{TOT} = E_{FE} + E_{RE}$	<i>Total energy consumed</i>	$kWh.m^{-2}.year^{-1}$
$\%_{FE}$	<i>Percentage of the fossil energy consumed compared with the total energy used</i>	%
I_C	<i>Comfort criterion</i>	%
I_P	<i>Performance criterion</i>	%
T_m	<i>Building's indoor mean temperature</i>	°C
T_{SP}	<i>Temperature set-point</i>	°C

2.3. Simulation: set-points and models

Because both the use and occupancy of a building impact on temperature set-point profiles, specific temperature instructions (for offices and residential buildings respectively), recommended by the French "Thermal Regulation 2005" [22], were used. This allows testing in several ways the robustness of the proposed control schemes. The lengths and the values of the temperature set-points are related to the building use (scholar, hospital...). For example, an office building has 3 temperature set-points (T_{SP}), 19°C, 16°C and 7°C, according to the hour of the day and the day of the week. Consequently, both the amplitude, ranging between 7°C and 22°C, and the frequency of temperature variations are weak. Restarting the regulation process after a break was also considered.

3. Simulation dynamic models

Dynamic models are necessary to test the proposed control schemes. The first dynamic model developed is a theoretical model, based on the thermal diffusivity equation that can be expressed as a temperature function. A second dynamic model describes the thermal behavior of a building mock-up. In both models, two heat sources are considered: the main source uses renewable energy, while the secondary source uses fossil energy.

3.1. Theoretical model

The theoretical model [23] was developed using Equation 2 and describes how temperature evolves in a building room.

$$\frac{\partial T}{\partial t} = \sum_{i=\{x,y,z\}} \left\{ a_i \frac{\partial^2 T}{\partial i^2} + \frac{h_i}{\rho_i C p_i} \cdot \frac{\partial T}{\partial i} + \sum_j \frac{a_{ij}}{\lambda_{ij}} P_j \right\} \quad [Eq. 2]$$

a	<i>Thermal diffusivity</i>	$m^{-2}.s^{-1}$
λ	<i>Thermal conductivity</i>	$W.m^{-1}.K^{-1}$
ρ	<i>Density</i>	$kg.m^{-3}$
Cp	<i>Specific heat capacity</i>	$J.kg^{-1}.K^{-1}$
h	<i>Heat transfer coefficient</i>	$W.m^{-2}.K^{-1}$
P_j	<i>Power density of the j^{th} heat source</i>	$W.m^{-3}$
t	<i>Time</i>	s
i	<i>Space coordinate</i>	m
T	<i>Temperature</i>	°C

To simplify the model, y and z axes are supposed to be infinite while the room is supposed to be constituted of homogenous and isotropic material. So, Equation 2 becomes Equation 3:

$$\frac{\partial T}{\partial t} = a_x \frac{\partial^2 T}{\partial x^2} + \frac{h}{\rho C p} \frac{\partial T}{\partial x} + \sum_j \frac{1}{\rho_{xj} C p_{xj}} P_j \quad [Eq. 3]$$

The three right-hand terms of Equation 3 depict the influence of conduction, convection and heat sources respectively. Two warmers are considered. To solve Equation 3, many explicit and implicit methods were tested, but the Crank-Nicholson discrimination method was preferred. Finally, Equation 4 focuses on the influence of external conditions, with ΔT the difference between outdoor temperature and the walls temperature. Using the theoretical dynamic model, preliminary results about heat resources management and indoor temperature control were promising [24]. That is why another dynamic model, describing the thermal behavior of an instrumented building mock-up, was developed to test the control schemes in conditions we want close to real conditions.

$$\frac{\partial T}{\partial t} = \frac{\Delta T}{\partial x} \cdot \frac{h}{\rho C p} \quad [Eq. 4]$$

3.2. Mock-up model

Having the possibility to instrument real buildings with a set of sensors and to test temperature controllers is not easy. That is why a building mock-up was built and instrumented [25]. Working with a mock-up gives flexibility concerning both sensors and heat sources localization. The lack of thermal inertia favors reactivity and avoids energy waste; a small amount of electricity is consumed for heating the mock-up. Its design is related to its scale, the building materials used and the possibility of easily quantifying the thermal losses. Instrumentation consists of eight temperature sensors (one outdoor sensor and seven indoor sensors) and two resistors used as heat sources. A monitoring system is used for collecting and treating data. Temperature and heat power datasets being needed to model the building mock-up, several tests were carried out according to various both the power of the two resistors and time periods. Figure 1 presents an example of temperatures acquisition during a period of about thirty days (from September 9, 2008 to October 6, 2008), with a sampling time of 60s.

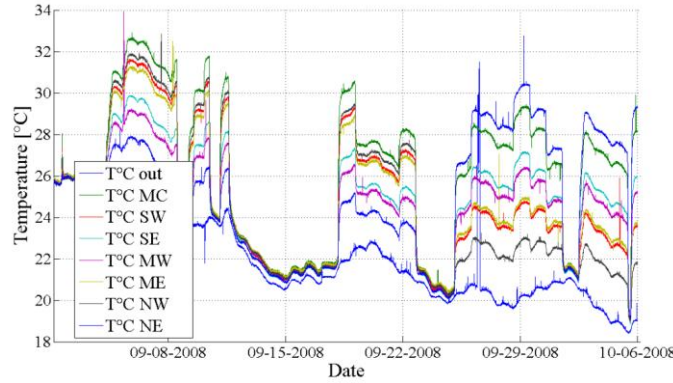

Figure 1. Mock-up temperatures acquisition.

The study of the mock-up thermal behavior leads to the model which structure is described by Equation 5. Using an iterative process of error minimization depicted by Equation 6, all the parameters of Equation 5 are identified for each of the seven temperature sensors ($i = 1, \dots, 7$):

$$T_i(k+1) = \alpha_i T_i(k) + \beta_{i1} u_1^{\rho_{i1}}(k) + \beta_{i2} u_2^{\rho_{i2}}(k) + \gamma_i T_{out}(k) \quad [Eq. 5]$$

$$\min_{\alpha_i, \beta_{i1}, \beta_{i2}, \rho_{i1}, \rho_{i2}, \gamma_i} \left[J = \sum_{k=1}^N (T_{mes}(k) - T_{mod}(k))^2 \right] \quad [Eq. 6]$$

with: $-1 < \alpha_i < 1$, $-10 < \beta_{i1} < 10$, $-10 < \beta_{i2} < 10$, $0 < \rho_{i1} < 1$, $0 < \rho_{i2} < 1$ and $-10 < \gamma_i < 10$.

T_i	Indoor temperature measured by the i^{th} sensor	$^{\circ}C$
T_{out}	Outdoor temperature	$^{\circ}C$
T_{mes}	Experimental temperature data	$^{\circ}C$
T_{mod}	Modeled temperature data	$^{\circ}C$
u_1	Power of the first heat source	W
u_2	Power of the second heat source	W
α_i	Inertia of temperature T_i	-
β_{i1} & ρ_{i1}	Influence of the first heat source on temperature T_i	-
β_{i2} & ρ_{i2}	Influence of the second heat source on temperature T_i	-
γ_i	Influence of outdoor temperature on temperature T_i	-
k	Time index ($t = k \cdot T_e$ and $T_e = 60s$)	-
J	Error criterion	-
N	Sample number	-

For each temperature, the fit (a similarity criterion) between measured and modeled data is computed using Equation 7. A mean similarity higher than 90% is obtained when carrying out the identification process. All the parameters of the mock-up model are listed by Table 1.

$$fit = 100 \times \left(1 - \frac{\|T_{mod} - T_{mes}\|_2}{\|T_{mes} - \langle T_{mes} \rangle\|_2} \right) \quad [Eq. 7]$$

Table 1. Parameters of the mock-up model.

$T_{SE} (T_1)$	$T_{SW} (T_2)$	$T_{NE} (T_3)$	$T_{NW} (T_4)$	$T_{ME} (T_5)$	$T_{MW} (T_6)$	$T_{MC} (T_7)$
$\alpha_1 = 0.981$	$\alpha_2 = 0.981$	$\alpha_3 = 0.982$	$\alpha_4 = 0.984$	$\alpha_5 = 0.984$	$\alpha_6 = 0.984$	$\alpha_7 = 0.979$
$\beta_{11} = 0.0209$	$\beta_{21} = 0.0327$	$\beta_{31} = 0.00859$	$\beta_{41} = 0.0314$	$\beta_{51} = 0.0248$	$\beta_{61} = 0.0150$	$\beta_{71} = 0.0408$
$\rho_{11} = 0.516$	$\rho_{21} = 0.478$	$\rho_{31} = 0.573$	$\rho_{41} = 0.443$	$\rho_{51} = 0.480$	$\rho_{61} = 0.489$	$\rho_{71} = 0.485$
$\beta_{12} = 0.0329$	$\beta_{22} = 0.0188$	$\beta_{32} = 0.0530$	$\beta_{42} = 0.0107$	$\beta_{52} = 0.0170$	$\beta_{62} = 0.0267$	$\beta_{72} = 0.0516$
$\rho_{12} = 0.501$	$\rho_{22} = 0.540$	$\rho_{32} = 0.447$	$\rho_{42} = 0.467$	$\rho_{52} = 0.513$	$\rho_{62} = 0.460$	$\rho_{72} = 0.461$
$\gamma_1 = 0.0193$	$\gamma_2 = 0.0192$	$\gamma_3 = 0.0179$	$\gamma_4 = 0.0161$	$\gamma_5 = 0.0160$	$\gamma_6 = 0.0163$	$\gamma_7 = 0.0209$

The seven equations obtained are then used in simulation for estimating the mock-up average indoor temperature and testing the proposed control schemes when applying the proposed energy management strategy. About disturbances, only outdoor temperature is taken into account.

4. Indoor temperature control schemes

Simulations were carried out for both testing the management strategy proposed (focusing on heating) and evaluating the performance of the indoor temperature control schemes developed, using the two just-mentioned models and a unique set of outdoor temperatures. The evaluation criteria (section 2.2) based on fossil and renewable energy consumption and on temperature set-point tracking were computed. Let's remember that both developed models incorporate two heat sources, a renewable energy warmer W_{RE} (the main heat source) and a fossil energy warmer W_{FE} (the secondary heat source). Respective powers are 700W ($U_{RE,max}$) and 300W ($U_{FE,max}$) for the theoretical model and 80W ($U_{RE,max}$) and 34W ($U_{FE,max}$) for the mock-up model. Moreover, and with the aim of being in agreement with common behaviors, in any case, the renewable energy warmer is used until power saturation is reached. At this point, the fossil energy warmer starts working. U_{RE} and U_{FE} are the power of W_{RE} and W_{FE} respectively, while k is the time index (Equation 8).

$$U_{RE}(k) = u(k) \text{ and } U_{FE}(k) = 0$$

- if $u(k) \geq U_{RE,max}$ then $U_{RE}(k) = U_{RE,max}$ and $U_{FE}(k) = u(k) - U_{RE}(k)$

if $U_{FE}(k) \geq U_{FE,max}$ then $U_{FE}(k) = U_{FE,max}$ else if $U_{FE}(k) \leq 0$ then $U_{FE}(k) = 0$ [Eq. 8]

- else if $u(k) \leq 0$ then $U_{RE}(k) = U_{FE}(k) = 0$

As a consequence, the renewable resource is firstly used. In addition, and this is the standard case, all the controllers' parameters are optimized to maximize the performance criterion I_p . In the same way, various constrains and additional parameters (they will be explained in the next sections) were considered when tuning the advanced control schemes (based on PID and MPC or FLC controllers), as required for taking into account the specific use of a building.

4.1. PID control scheme

A standard PID controller is a control mechanism [26], widely used in buildings engineering for heating control [5-9]. That is why it was considered as the reference controller and was the basic component of the proposed advanced control schemes (PID-MPC and PID-FLC schemes). Let us remind its structure (Figure 2) for discrete time control with anti-windup considerations (Equation 9). Using $\varepsilon = T_{SP} - T_m$, the controller computes u_{PID} (the "unsaturated" heat power). $u_{sat_{PID}}$ (the "saturated" heat power) then both U_{RE}^{PID} (the power of W_{RE}) and U_{FE}^{PID} (the power of W_{FE}) are deduced from u_{PID} . Outdoor temperature impacts on indoor temperature and is as a consequence considered as a disturbance. The anti-windup system was realized using a standard method. It controls the PID integral action and preserves both the stability and the performance of the closed-loop.

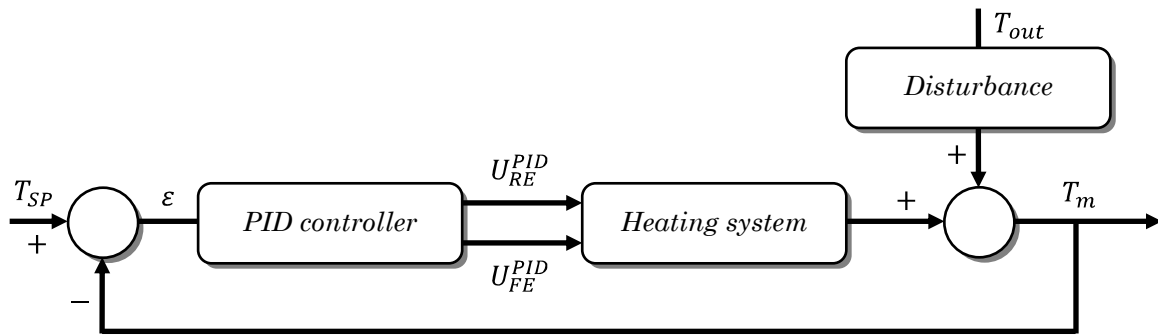

Figure 2. Framework of the PID control scheme.

$$\left\{ \begin{array}{l} U_{max} = U_{RE_max} + U_{FE_max} \\ T_{aw} = \frac{T_e}{K_I} \\ x_I(k) = x_I(k-1) + K_I \cdot (T_{SP}(k) - T_m(k)) \\ x_D(k) = K_D \cdot x_D(k-1) + (T_m(k-1) - T_m(k)) \\ u_{PID}(k) = K_P \cdot (T_{SP}(k) - T_m(k) + x_I(k) + x_D(k)) \quad [Eq. 9] \\ u_{sat_{PID}}(k) = u_{PID}(k) \\ \text{if } u_{PID}(k) > U_{max} \text{ then } u_{sat_{PID}}(k) = U_{max} \\ \text{if } u_{PID}(k) < 0 \text{ then } u_{sat_{PID}}(k) = 0 \\ x_I(k) = x_I(k) + \left(\frac{T_e}{K_P \cdot T_{aw}} \right) \cdot (u_{sat_{PID}}(k) - u_{PID}(k)) \end{array} \right.$$

T_m	Building's indoor mean temperature	°C
T_{SP}	Temperature set-point	°C
K_P	Proportional gain	-
K_I	Integral gain	-
K_D	Derivative gain	-
T_e	Sampling time	s
T_{aw}	Anti-windup time constant	s
x_I	Integration state	-
x_D	Derivation state	-
u_{PID}	Unsaturated heat power (computed by the PID controller)	W
$u_{sat_{PID}}$	Saturated heat power (computed by the PID controller)	W
U_{max}	Maximum heat power	W

With the aim of optimizing the performance criterion I_p , Equation 10 allows finding the most accurate coefficients of the PID controller.

$$\max_{K_P, K_I, K_D} (I_p = I_C - \%_{FE}) \quad [Eq. 10]$$

with: $0 < K_P < 100$, $0 < K_I < 1$ and $0 < K_D < 1$.

4.2. PID-MPC control scheme

A model predictive controller is a model-based and discrete controller allowing calculating an optimal command sequence. To elaborate this sequence, one needs both a linear model and a working point of the system to be controlled [27-28]. Future set-point knowledge and external disturbances forecast allow anticipating set-point changes and taking into account the influence of these disturbances. The MPC controller used estimates the way outdoor temperature is evolving on a prediction horizon H_p and computes optimal increments on a command horizon H_C (shorter than H_p). So, a new optimization is carried out for each time step. The values of the two horizons are the following ones, for the theoretical and mock-up models, respectively: $H_p = 60$ minutes and $H_C = 30$ minutes, $H_p = 10$ minutes and $H_C = 5$ minutes. The advanced heating control scheme proposed, depicted by Figure 3, is defined according to the following guidelines: the PID controller (the basic component of the control scheme proposed) estimates the power of W_{RE} (U_{RE}^{PID}), while the MPC controller, using the forecasted outdoor temperature T_{out} , the temperature set-point T_{SP} and the mean temperature inside the considered building T_m , specifies the power of W_{FE} (U_{FE}^{MPC}) and if the power of W_{RE} needs to be adjusted (U_{RE}^{MPC}).

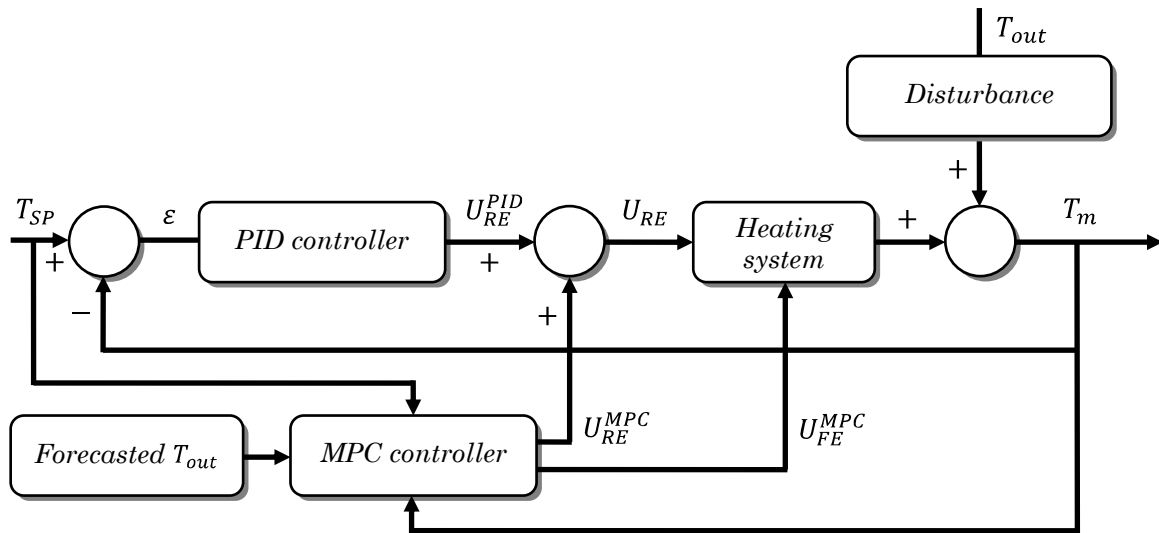

Figure 3. Framework of the PID-MPC control scheme.

Being a model-based controller is one of the main drawbacks of the MPC controller, jointly to its very extensive on-line computational effort, but, in the other hand, it can inherently handle constraints [27-28]. Equation 11 describes the objective function, based on indoor temperature set-point tracking and fossil energy consumption, used for calculating the optimal sequences about heat power (U_{RE}^{MPC} and U_{FE}^{MPC}) and how the constraints are defined, according to both the considered model (Equation 3 or Equation 5) and the PID controller equations (Equation 9). As a key-point, let us specify that a weight ω has been assigned to U_{FE}^{MPC} with the aim of impacting significantly on the fossil energy consumption. Section 5.1 focuses on the impact of this weight on the evaluation criteria proposed (section 2.2) and the way one can use it to take into account the specific use of a multi-energy building when implementing the management strategy proposed.

$$\min_{\Delta u(k/k), \dots, \Delta u(k+c-1/k)} \sum_{j=0}^{p-1} \left(|T_m(k+j+1/k) - T_{SP}(k+j+1)|^2 + |\omega \cdot U_{FE}^{MPC}(k+j/k)|^2 \right) \quad [Eq. 11]$$

with the following constraints: $0 \leq U_{RE}(k+j/k) \leq U_{RE_max}$, $0 \leq U_{FE}(k+j/k) \leq U_{FE_max}$ and $\Delta u(k+h) = 0$, $h = \{c, \dots, p-1\}$.

k	<i>Time index</i>	-
p	<i>Prediction horizon index</i>	-
c	<i>Command horizon index</i>	-
Δu	<i>Command increment</i>	W
T_m	<i>Building's indoor mean temperature</i>	$^{\circ}\text{C}$
T_{SP}	<i>Temperature set-point</i>	$^{\circ}\text{C}$
ω	<i>Weight assigned to U_{FE}^{MPC}</i>	-

Testing several values of ω , one can find the right value allowing maximizing the performance criterion I_p (Equation 12). Let us remember that according to the specific use of a multi-energy building or because the way energy resources are managed has changed, one can also choose the value of ω with the aim of minimizing the consumption of fossil energy or favoring thermal comfort.

$$\max_{\omega} (I_p = I_c - \%_{FE}) \quad [Eq. 12]$$

with: $0.005 < \omega < 10$.

4.3. PID-FLC control scheme

Both the structure of the control scheme and the heating control strategy remain the same as when using model predictive and PID controllers (Figure 4). Let us just remember that the concept of fuzzy sets deals with the representation of classes whose boundaries are not quite determined. Fuzzy sets can be defined by exemplification, ranking elements according to their typicality with respect to the concept underlying the sets. They preserve a gradual and smooth transition from one category into another and avoid abrupt discontinuities [29]. Their ability and possibility theory to model gradual properties or soft constraints whose satisfaction is a matter of degree, as well as information pervaded with imprecision and uncertainly, makes them useful in a great variety of applications [30-35]. That is why the PID-FLC scheme is proposed for easily taking into account the specific use of a building, thanks to the design of appropriate fuzzy rules [36]. From the difference between the set-point temperature (T_{SP}) and the indoor mean temperature (T_m), the PID controller estimates the power of W_{RE} (U_{RE}^{PID}) while a 1st fuzzy module determines if this power needs to be corrected (U_{RE}^{FLC}). From ε and $U_{RE} = U_{RE}^{PID} + U_{RE}^{FLC}$, a 2nd fuzzy module evaluates the power of W_{FE} (U_{FE}^{FLC}).

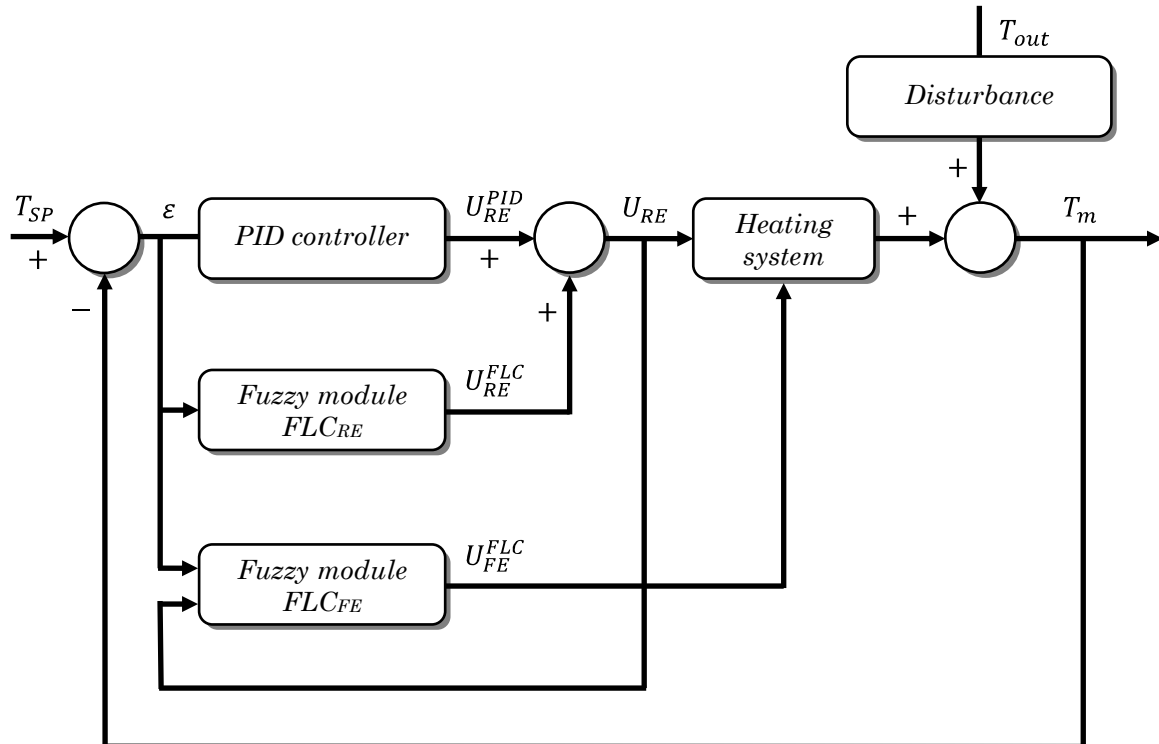

Figure 4. Framework of the PID-FLC control scheme.

The values of U_{RE}^{FLC} and U_{FE}^{FLC} are normalized between -1 and +1 ($U_{RE}^{FLC} \in [-1; +1]$) and 0 and +1 ($U_{FE}^{FLC} \in [0; +1]$) respectively, then denormalized using the gains K_{RE} and K_{FE} . One needs, first, to characterize all the above-mentioned parameters and their respective "universes of discourse" using fuzzy sets and membership functions and, secondly, to design appropriate fuzzy rules (section 5.2.1.) that map inputs to outputs, with the aim of optimizing the performance criterion I_p (thanks to the fuzzification process and the design of the fuzzy rules, one can easily take into account the specific use of a multi-energy building, favoring thermal comfort or minimizing the fossil energy consumption). Equation 13 describes the way this criterion can be maximized, jointly optimizing all the controllers' gains (K_p, K_I, K_D, K_{FE} and K_{RE}), according to the system model.

$$\max_{K_p, K_I, K_D, K_{RE}, K_{FE}} (I_p = I_c - \%_{FE}) \quad [Eq. 13]$$

with: $0 < K_p < 100, 0 < K_I < 1, 0 < K_D < 1, 0 < K_{FE} < 1000$ and $0 < K_{RE} < 1000$.

5. Results and discussion

This section focuses on the results obtained when applying the proposed strategy, allowing managing energy resources in a multi-energy building, using the mock-up model. Because the results are similar when using the theoretical model, they will not be presented. The impact on the evaluation criteria (I_c, I_p and $\%_{FE}$) of the weight assigned to U_{FE}^{MPC} (PID-MPC control scheme), the fuzzification phase, and the design of the fuzzy rules (PID-FLC control scheme) was examined with the aim of answering to the following question: how indoor temperature controllers can be adapted to the specific use of a building? Finally, the results obtained when using the PID-MPC and PID-FLC control schemes are compared to the reference results (provided by the PID scheme).

5.1. Impact on the evaluation criteria of the weight ω assigned to U_{FE}^{MPC} (PID-MPC scheme)

To answer to the just-mentioned question, one needs, first, to understand how the proposed criteria are evolving, considering the weight ω assigned to U_{FE}^{MPC} and designed to limit the use of fossil energy (Equation 14). Table 2 and Figures 5 and 6 depict, according to both the temperature set-points chosen to deal with offices and houses respectively and a weight ω ranging between 0.0001 and 10, the respective values of I_c, I_p and $\%_{FE}$. Table 2 also deals with renewable and fossil energy consumptions. Taking a look at the just-mentioned table and figures, one can first note that, whatever the use of the building, a weak ω favors comfort (I_c) while a strong ω promotes fossil energy savings ($\%_{FE}$): in other words, the higher is the weight assigned to U_{FE}^{MPC} ($\%_{FE} \rightarrow 0$), limiting the use of renewable energy, the lower are the criteria I_c and I_p . However, the use of a building determines which is the optimal value of ω : for example, a bad comfort criteria is not suitable for hospitals while a scholar building can promote energy savings during holidays.

Table 2. Respective values of the evaluation criteria and energy consumption according to the weight ω assigned to U_{FE}^{MPC} (offices and houses).

ω/PID	Offices					Houses				
	E_{RE} [Wh.m ⁻²]	E_{FE} [Wh.m ⁻²]	$\%_{FE}$ [%]	I_c [%]	I_p [%]	E_{RE} [Wh.m ⁻²]	E_{FE} [Wh.m ⁻²]	$\%_{FE}$ [%]	I_c [%]	I_p [%]
PID	7494.29	521.02	6.50	72.03	65.53	7414.05	786.73	9.62	61.86	60.24
10	7303.86	338.03	4.42	71.06	66.64	7394.28	343.15	4.44	65.42	60.98
5	7303.86	338.04	4.42	71.06	66.64	7395.89	342.81	4.43	65.42	60.99
3	7303.86	338.06	4.42	71.06	66.64	7395.83	342.22	4.42	65.42	61.00
1	7303.78	338.19	4.43	71.08	66.65	7402.64	342.31	4.42	65.44	61.02
0.5	7305.36	338.38	4.43	71.12	66.69	7408.75	341.33	4.40	65.52	61.12
0.2	7304.83	341.73	4.47	71.44	66.97	7404.29	348.79	4.50	65.84	61.34
0.1	7300.59	351.82	4.60	72.32	67.72	7411.77	367.92	4.73	67.03	62.31
0.05	7339.24	381.16	4.94	73.63	68.70	7406.36	432.56	5.52	69.56	64.05
0.03	7341.20	429.50	5.53	74.12	68.60	7376.96	538.35	6.80	71.26	64.45
0.02	7349.52	485.72	6.20	74.37	68.17	7410.01	642.32	7.98	72.14	64.16
0.01	7313.96	561.85	7.13	73.98	66.84	7379.45	791.97	9.69	71.92	62.23
0.001	7239.58	626.28	7.96	73.55	65.59	7322.18	894.65	10.89	71.18	60.30
0.0001	7383.21	625.69	7.81	73.55	65.73	7395.39	903.41	10.89	71.19	60.30

So, whatever the set-point (for offices or houses), any weights can be assigned to W_{FE} according to both the control specific requirements and the specific use of a multi-energy building. One can notice that, for offices, $\omega = 0.05$ is the best compromise between comfort and fossil energy use, the performance criterion being maximal ($I_{P_max}(\text{offices}) = 68.70\%$). For houses, $\omega = 0.03$ leads to $I_{P_max}(\text{houses}) = 64.45\%$. Let us also note that, whatever the use of the building, $\omega = 0.02$ allows maximizing the comfort criterion ($I_{C_max}(\text{offices}) = 74.37\%$; $I_{C_max}(\text{houses}) = 72.14\%$).

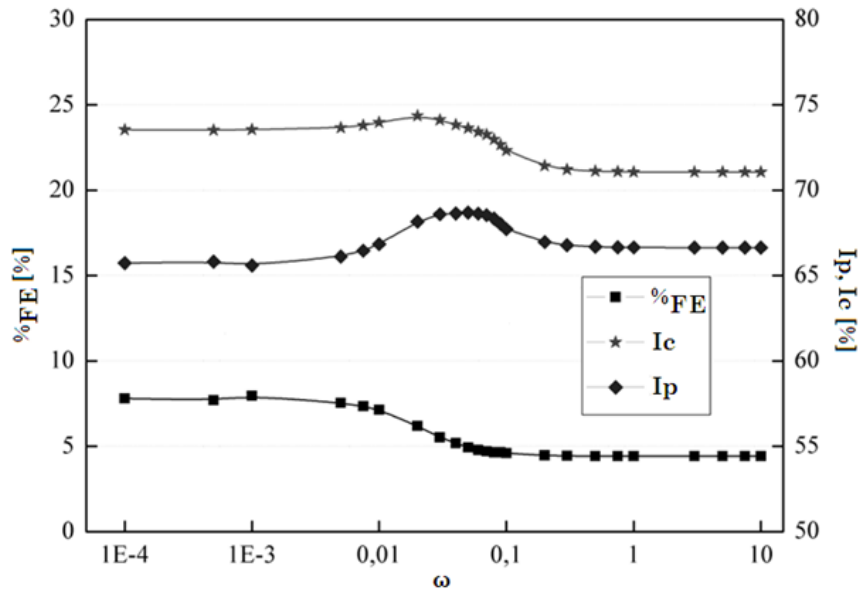

Figure 5. Impact of the weight ω on the evaluation criteria (offices).

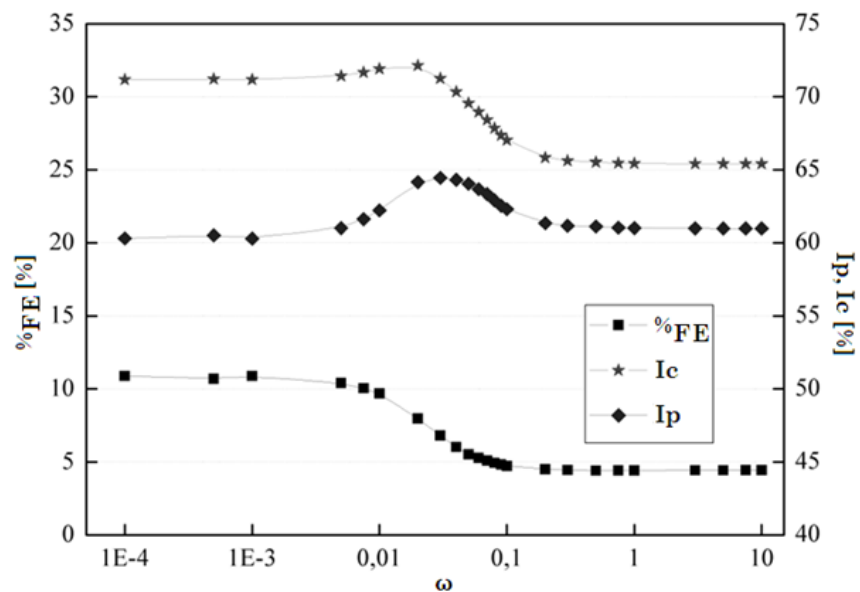

Figure 6. Impact of the weight ω on the evaluation criteria (houses).

Taking as a reference the performance of the PID scheme, one can observe that the PID-MPC scheme, considering offices (ω is set to 0.05), allows reducing the percentage of the fossil energy consumed compared with the total energy used by 24%, from 6.50% to 4.94%, and increasing both the comfort and performance criteria by 2.2%, from 72.03% to 73.63%, and 4.8%, from 65.53% to 68.70%, respectively. Similar results are obtained for houses (ω is set to 0.03): the PID-MPC scheme allows reducing $\%FE$ by 29.3%, from 9.62% to 6.80%, and increasing both criteria I_C and I_P by 15.2%, from 61.86% to 71.26%, and 7%, from 60.24% to 64.45%, respectively. Even though some of these percentages seem to be weak, they are significant due to the average life of buildings.

Taking another look at Table 2 and again taking as a reference the performance of the PID control scheme, one can also note that, whatever the set-point, the PID-MPC control scheme allows reducing significantly the fossil energy consumption while the renewable energy consumption remains stable or decreases slightly. For offices (ω is set to 0.05), E_{FE} is reduced by 26.8%, from 521.02 Wh.m⁻² to 381.16 Wh.m⁻², while E_{RE} is reduced by 2%, from 7494.29 Wh.m⁻² to 7339.24 Wh.m⁻². For houses (ω is set to 0.03), E_{FE} is reduced by 31.6%, from 786.73 Wh.m⁻² to 538.35 Wh.m⁻², while E_{RE} is reduced by 0.5%, from 7414.05 Wh.m⁻² to 7376.96 Wh.m⁻².

5.2. Impact on the evaluation criteria and on energy consumption of the fuzzification phase and both the number and the design of fuzzy rules (PID-FLC scheme)

5.2.1. Universes of discourse

Let us remember the structure of the PID-FLC scheme (Figure 4): from the difference between the set-point temperature and the indoor mean temperature (ε), the PID controller estimates the power of W_{RE} (U_{RE}^{PID}) while a first fuzzy module determines if this power needs to be corrected (U_{RE}^{FLC}). From both ε and $U_{RE} = U_{RE}^{PID} + U_{RE}^{FLC}$, a second fuzzy module evaluates the power of W_{FE} (U_{FE}^{FLC}). As previously mentioned, one needs, first, to characterize the fuzzy modules' input and output parameters and their "universes of discourse" using fuzzy sets, triangular or trapezoidal-shaped membership functions (the membership functions are chosen to be bell-shaped with a minimum and a maximum equal to 0 and 1 respectively) and linguistic labels and, secondly, to design appropriate fuzzy rules, with the aim of maximizing the performance criterion I_p (let us remember that this is the "standard" case but the design of the fuzzy rules can be adapted with the aim of maximizing the comfort criterion I_c or minimizing the percentage of the fossil energy consumed compared with the total energy used % $_{FE}$). Because of the thermal inertia, heat transfers between adjacent thermal zones and the heating system dimensioning, indoor temperatures in buildings may be in the range 0°C-30°C. Moreover, and according to the "Thermal regulation 2005", temperature set-points (T_{sp}) may be in the range 7°C-22°C. As a result, values for the difference between the set-point temperature and the (current) mean indoor temperature range between -24°C and +24°C ($\varepsilon \in [-24^\circ\text{C}; +24^\circ\text{C}]$). As previously mentioned, the values of U_{RE}^{FLC} and U_{FE}^{FLC} are normalized between -1 and +1 and 0 and +1 respectively then denormalized using the gains K_{RE} and K_{FE} . So, $U_{RE}^{FLC} \in [-1; +1]$ and $U_{FE}^{FLC} \in [0; +1]$. Finally, U_{RE} being saturated at 80W, the universe of discourse of U_{RE} is defined as follows: $U_{RE} \in [0W; 80W]$. To be concise and because, whatever the set-point, similar results are obtained, only results for offices will be presented in the following sections of the paper.

5.2.2. Optimal configuration allowing maximizing the performance criterion I_p

Let us note that, because of measurement error due to the data acquisition tool used, control accuracy is $\pm 0.5^\circ\text{C}$. Usually, one considers that energy consumption increases by 7% over a year if the regulated indoor temperature rises above the set-point by 1°C. Both factors were considered during the fuzzification phase of the parameters. Let us also note that the control tool was designed without any consideration about control speed which is, however, a significant criterion in control engineering. Nevertheless, and with the aim of avoiding both the saturation of the renewable energy resource and set-point overflow, a progressive relaunch of the control process was promoted. Table 3 summarizes all the significant results, obtained when using the PID-FLC control scheme for implementing the proposed energy management strategy, according to the fuzzification of the modules' input and output parameters and both the number and the design of the fuzzy rules. Nine configurations are proposed (from A to I). Table 3 highlights how the just-mentioned considerations are related with both the previously-defined criteria I_p , I_c and % $_{FE}$ and (fossil and renewable) energy consumption, when implementing the proposed control scheme in an office while taking into account its use and specific constraints. Increasing, from a starting configuration (A), the number of both the fuzzy sets (common triangular or trapezoidal membership functions and linguistic labels were associated to the sets) used to split the respective universes of discourse of the modules' input and output parameters and the fuzzy rules led to the optimal configuration (E) which maximizes the performance criterion (I_p). Let us also note, first, that the shape of the triangular membership functions used for characterizing ε around zero was adjusted (the length of their respective bases was reduced) from configuration B (this configuration allows minimizing % $_{FE}$) to configuration C (this configuration leads to very good performance, rather

close to the performance of the optimal configuration E, but using less fuzzy rules) then from configuration D to configuration E (in this case, the number of fuzzy sets has also increased from 5 to 7) (Figure 7), secondly, that the design of the fuzzy rules was modified from configuration E to configuration F then from configuration F to configuration G and, finally, that the shape of the triangular membership functions used for characterizing U_{RE}^{FLC} was adjusted (the length of their respective bases was extended) from configuration H to configuration I. Finally, taking a look at configurations A to I, one can first highlight the two following key-points: (1) the difference between the set-point temperature and the current temperature (used as fuzzy modules input) has to be characterized by splitting its chosen universe of discourse into enough fuzzy sets, notably around zero, to obtain a good comfort criterion (I_C) and to avoid oscillations of the controlled temperature around the set-point; (2) splitting the universe of discourse of U_{FE}^{FLC} into enough fuzzy sets allows limiting the use of fossil energy and improves consequently the criterion $\%_{FE}$. Both key-points impact the performance criterion (I_P) and define the way the PID-FLC control scheme can be implemented according to the use of a building.

Table 3. Impact on the evaluation criteria and on energy consumption (offices) of the fuzzification phase and both the number and the design of fuzzy rules (PID-FLC scheme).

Configuration	Module FLC_{RE}			Module FLC_{FE}				E_{RE} [Wh.m ⁻²]	E_{FE} [Wh.m ⁻²]	$\%_{FE}$ [%]	I_C [%]	I_P [%]
	ε	U_{RE}^{FLC}	Rules	ε	U_{RE}	U_{FE}^{FLC}	Rules					
PID	-	-	-	-	-	-	-	7494.29	521.02	6.50	72.03	65.53
A	3	3	3	3	2	3	6	7236.19	473.99	6.15	59.69	53.54
B	5	5	5	5	2	5	10	7779.79	338.76	4.17	62.07	57.90
C	5	5	5	5	2	5	10	7504.92	480.95	6.02	72.14	66.12
D	5	5	5	5	2	3	10	7700.20	619.18	7.44	70.78	63.33
E	7	5	7	7	2	5	14	7731.35	470.66	5.74	72.38	66.64
F	7	5	7	7	2	5	14	7470.84	625.22	7.72	71.05	63.32
G	7	5	7	7	2	5	14	7426.40	654.02	8.09	71.08	62.98
H	7	5	7	7	2	4	14	7470.84	625.22	7.72	71.05	63.32
I	7	5	7	7	2	4	14	6709.86	760.13	10.2	69.48	59.31

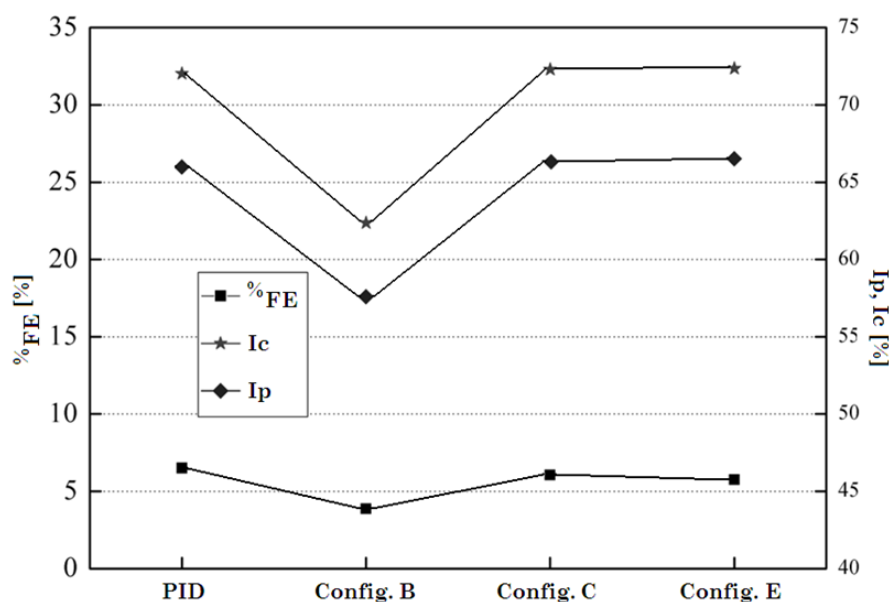

Figure 7. Remarkable configurations (offices).

Taking again as a reference the performance of the PID scheme, one can observe that the PID-FLC scheme (when considering the optimal configuration E), allows reducing the percentage of the fossil energy consumed compared with the total energy used by 11.7%, from 6.50% to 5.74%, while increasing both the comfort and the performance criteria by 0.5%, from 72.03% to 72.38%, and 1.7%, from 65.53% to 66.64%, respectively. Looking at Table 3, one can also note that configuration

E provides the highest comfort criterion among all of the configurations we studied and that fossil energy consumption is significantly reduced while renewable energy consumption increases moderately: E_{FE} is reduced by 9.7%, from 521.02 Wh.m⁻² to 470.66 Wh.m⁻², while E_{RE} is increased by 3.2%, from 7494.29 Wh.m⁻² to 7731.35 Wh.m⁻². Similar results are obtained for houses.

Figures 8, 9, 10 and 11 present the respective fuzzifications of ε , U_{RE} , U_{RE}^{FLC} and U_{FE}^{FLC} while Tables 4 and 5 depict the two sets of fuzzy rules (modules FLC_{FE} and FLC_{RE}) characterizing configuration E. The following (usual) linguistic labels were associated to the fuzzy sets: NH (Negative High), NM (Negative Medium), NL (Negative Low), AZ (Approximately Zero), PL (Positive Low), PM (Positive Medium) and PH (Positive High) for ε , U_{RE_unsat} and U_{RE_sat} for U_{RE} , NH (Negative High), NL (Negative Low), AZ (Approximately Zero), PL (Positive Low) and PH (Positive High) for U_{RE}^{FLC} and, finally, null, weak, medium, strong and full for U_{FE}^{FLC} .

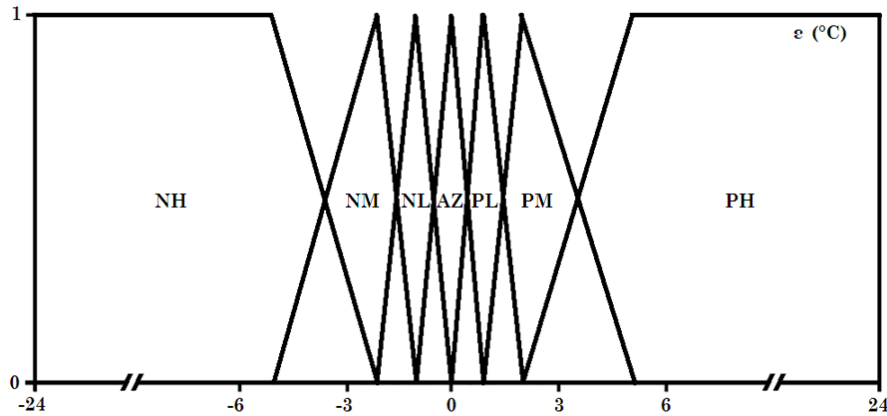

Figure 8. Fuzzification of ε (optimal configuration E).

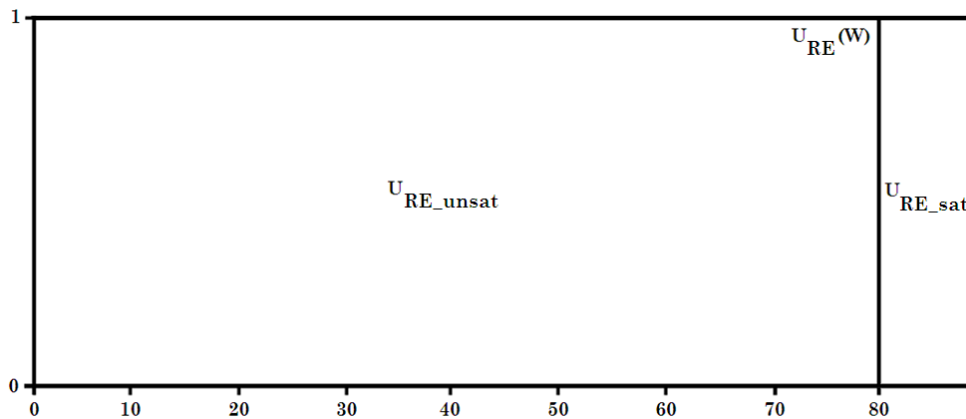

Figure 9. Fuzzification of U_{RE} (optimal configuration E).

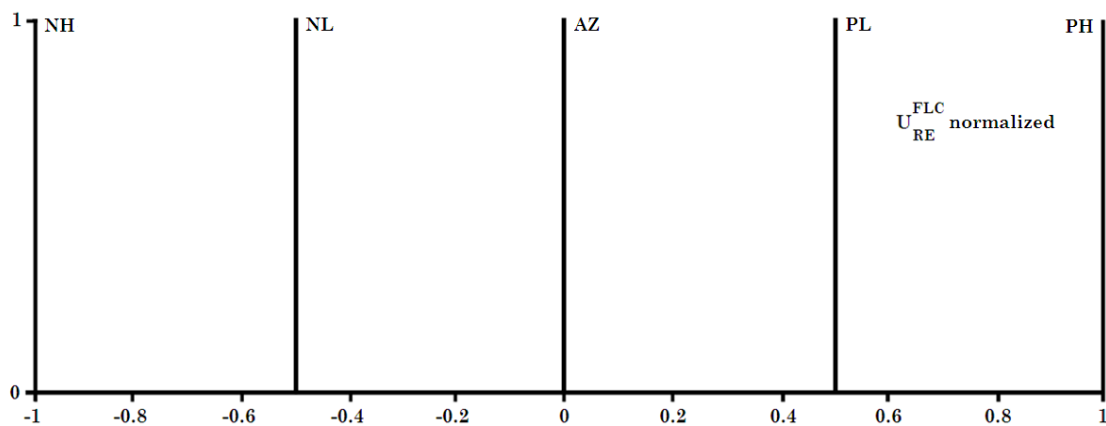

Figure 10. Fuzzification of U_{RE}^{FLC} (optimal configuration E).

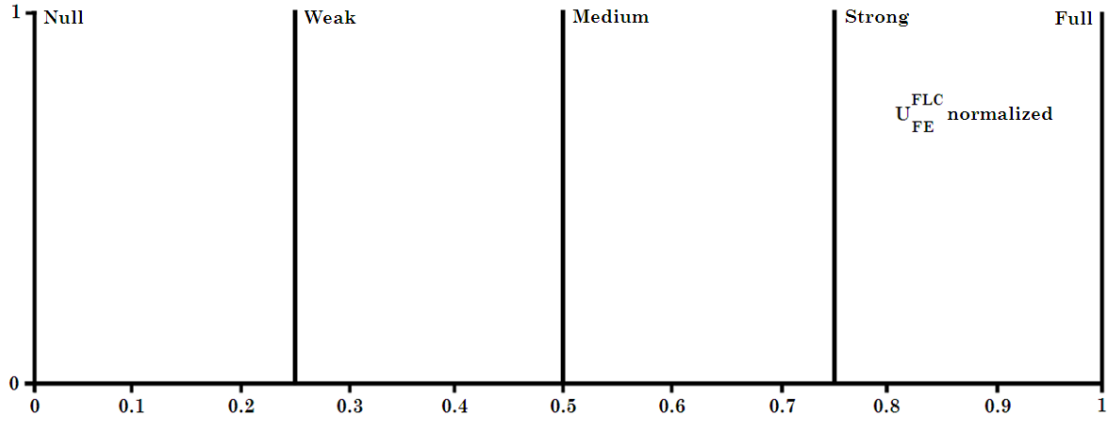

Figure 11. Fuzzification of U_{FE}^{FLC} (optimal configuration E).

Table 4. Fuzzy rules for module FLC_{RE} (optimal configuration E).

Module	Rule	1	2	3	4	5	6	7
FLC_{RE}	ε	NH	NM	NL	AZ	PL	PM	PH
	U_{RE}^{FLC}	NH	NH	NL	AZ	PL	PL	PH

Table 5. Fuzzy rules for module FLC_{FE} (optimal configuration E).

Module	Rule	1	2	3	4	5	6	7
FLC_{FE}	ε	NH	NM	NL	AZ	PL	PM	PH
	U_{RE}	U_{RE_unsat}	U_{RE_unsat}	U_{RE_unsat}	U_{RE_unsat}	U_{RE_unsat}	U_{RE_unsat}	U_{RE_unsat}
	U_{FE}^{FLC}	Null	Null	Null	Null	Null	Null	Null
	Rule	8	9	10	11	12	13	14
	ε	NH	NM	NL	AZ	PL	PM	PH
	U_{RE}	U_{RE_sat}	U_{RE_sat}	U_{RE_sat}	U_{RE_sat}	U_{RE_sat}	U_{RE_sat}	U_{RE_sat}
	U_{FE}^{FLC}	Null	Null	Null	Weak	Medium	Strong	Full

5.2.3. Design of new rules for improving the control quickness

As just-highlighted, considering the PID-FLC scheme, the way the fuzzy rules are designed, related not only to the proposed control strategy but also to the fuzzification of the fuzzy modules' input and output parameters, directly impacts both the evaluation criteria and the closed-loop performance. Let us talk about some highlights from the proposed fuzzy rules for module FLC_{RE} (configuration E) (Table 4). First, the rule "IF ε is NM THEN U_{RE}^{FLC} is NH" (rule #2) was designed with the aim of both making faster the control and limiting the power of W_{RE} : when it is too hot, heating has to be significantly reduced. About the rule "IF ε is PM THEN U_{RE}^{FLC} is PL" (rule #6), it was designed to limit the power of W_{RE} during heating times: when it is too cold, heating has to be slightly increased. With the aim of giving flexibility to the proposed control strategy and thanks to some specific adjustments of the two just-mentioned rules (rules #2 and #6), one can try to improve the control quickness. The first way (this leads to configuration E') is designing the rule #6 as follows: "IF ε is PM THEN U_{RE}^{FLC} is PH" (when it is too cold, heating has to be significantly increased). The second way (this leads to configuration E'') is designing the rule #2 as follows: "IF ε is NM THEN U_{RE}^{FLC} is NL" (when it is too hot, heating has to be slightly reduced). While the control quickness is improved, these two adjustments also lead to increasing the criterion $\%_{FE}$ and decreasing both the comfort and performance criteria I_p and I_c (Figure 12). In all cases, the design of the fuzzy rules reflects a compromise between thermal comfort and energy consumption, taking into account a given situation and the specific use of a building. Finally, let us note that, to avoid incoherent behaviors and to be in agreement with the proposed strategy, some potential rules were obviously not taken into account, such as the following ones: "IF ε is NL THEN U_{RE}^{FLC} is

PM " (when it is slightly too hot, heating has to be significantly increased) or " $IF \varepsilon$ is PL THEN U_{RE}^{FLC} is NL " (when it is slightly too cold, heating has to be slightly reduced).

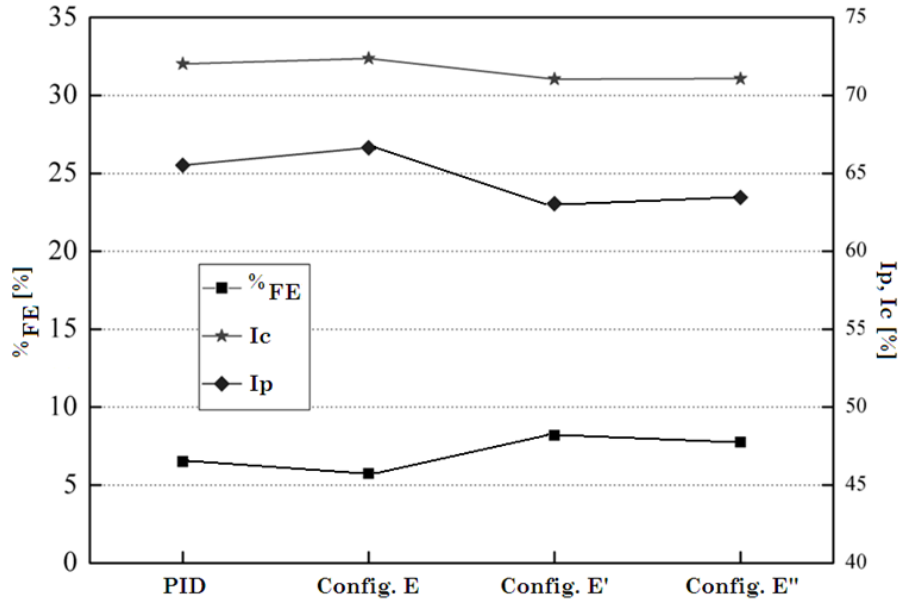

Figure 12. New configurations for improving the control quickness (offices).

5.2.4. Synthesis and temperature set-point tracking

The present section deals with the synthesis of the results obtained, using both the mock-up model and one of the control schemes developed (PID, PID-MPC and PID-FLC), when applying the proposed energy management strategy, focusing on heating and indoor temperature, to multi-energy buildings. Let us remember that, whatever the temperature set-point (for offices or houses), similar results are obtained. That why only results about offices will be presented again. Table 6 summarizes the respective performance of the control schemes proposed, taking into consideration the fossil and renewable energy consumed and the respective values of $\%_{FE}$, I_C and I_P .

Table 6. Respective performance of the PID, PID-MPC and PID-FLC control schemes (offices).

Control scheme	E_{RE} [$Wh \cdot m^{-2}$]	E_{FE} [$Wh \cdot m^{-2}$]	$\%_{FE}$ [%]	I_C [%]	I_P [%]
PID	7494.29	521.03	6.50	72.03	65.53
PID-MPC	7339.24	381.16	4.94	73.63	68.70
PID-FLC	7731.35	470.66	5.74	72.38	66.64

As a synthesis, one can first highlight that, concerning energy consumption, savings of fossil energy are about 26.9% when using the PID-MPC scheme and about 9.8% when using the PID-FLC scheme. At the same time, renewable energy consumption slightly decreases with the PID-MPC scheme (about 2%) while it increases by 3.2% with the PID-FLC scheme. Without any doubt, and whatever the parameter considered, the PID scheme obtains the worst results over the other considered control schemes. The PID-MPC control scheme is the best performer, mainly because of a low consumption of fossil energy i.e. because of the lowest $\%_{FE}$ and the highest comfort criterion (I_C), leading to the best performance criterion (I_P), about 3% higher than when using the PID-FLC control scheme. However, developing and testing a PID-MPC controller is harder and longer than developing and testing a classical PID controller and, as previously mentioned, requires an accurate model of the building, not always easy to obtain. Furthermore, implementing this kind of advanced controllers needs an embedded numerical optimizer and a fast microprocessor. As an example, Figure 13 depicts the temperature set-point tracking using the three proposed schemes. Whatever the scheme, this tracking can be considered as satisfactory. However, taking a look at the figure, one can observe specific behaviors (notably when outdoor temperature decreases) as a result of a compromise between set-point tracking and energy consumption and related to both

the design of the fuzzy rules (PID-FLC scheme) and the way the PID-MPC's objective function (including a weight ω assigned to U_{FE}^{MPC}) is formulated.

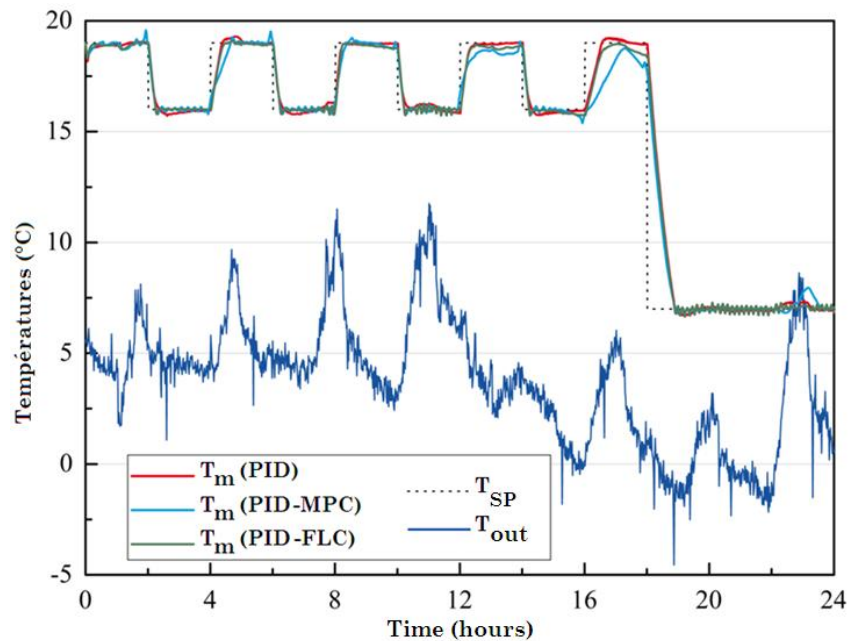

Figure 13. Temperature set-point tracking using the PID, PID-MPC and PID-FLC control schemes (offices).

6. Conclusion

Taking into consideration the European energy context and according to the latest laws meeting EU requirements about energy certification schemes for buildings, the present paper focuses on investigating ways for improving the energy performance of buildings. That is why an efficient and widely-adaptable strategy, based on the specific use of a building and allowing managing both fossil and renewable energy resources in multi-energy buildings, is proposed. Indoor temperature control schemes were developed with the aim of favoring energy savings and increasing the renewable energy contribution, while ensuring thermal comfort. Because of its significant impact on energy consumption, heating is the key-point (it account for about 60% of all delivered energy consumed in buildings). Moreover, and because PID controllers are commonly used in buildings engineering, the advanced control schemes proposed (both PID-MPC and PID-FLC schemes) are built on the basis of a PID controller. This allows implementing these schemes in buildings even if a control system based on such a controller is already in use and improving its performance. A MPC (Model Predictive Controller) is a versatile and powerful model-based and discrete controller allowing calculating an optimal command sequence while a FLC (Fuzzy Logic Controller) provides a remarkably simple way to draw definite conclusions from vague, imprecise or missing information, incorporating a linguistic rule-based approach.

Because both the use and occupancy of a building impact on temperature set-point profiles, specific temperature instructions (for offices and residential buildings respectively), recommended by the French "Thermal Regulation 2005", were used. Dynamic models being necessary to test the proposed control schemes, a theoretical model, based on the thermal diffusivity equation that can be expressed as a temperature function, was first developed. A second dynamic model describes the thermal behavior of an instrumented building mock-up. In both models, two heat sources are considered: the main source uses renewable energy, while the secondary source uses fossil energy. Finally, and because the building's Energy Performance Indicator (commonly used to classify buildings) does not dissociate the various energy consumption components and does not explain how energy is consumed in buildings, criteria (about fossil energy consumption, thermal comfort and control performance) describing the way energy is used and controlled in real-time were defined with the aim of evaluating both the energy management strategy and the indoor temperature control schemes proposed.

Despite some limitations due to specific features, the commonly-used PID scheme provided pretty good simulation results. However, its performance is the worst among the three tested control schemes. The results that best meet the proposed strategy objectives are provided by the PID-MPC scheme, as a result of both the lowest $\%_{FE}$ and the highest comfort criterion (I_C), consequently leading to the best performance criterion (I_p). When implementing the PID-MPC scheme, the weight assigned to the power of the renewable energy warmer impacts significantly on the fossil energy consumption. However, and because the MPC controller is a model-based controller which on-line computational effort is extensive, developing and implementing such a controller is a quite hard task. The PID-FLC scheme also provided better results than the PID scheme. Thanks to the flexibility offered by both the fuzzification of the fuzzy modules' input and output parameters and the design of the fuzzy rules, the PID-FLC scheme allows favoring one of the evaluation criteria defined and adapting to the specific use of a building. As a consequence, it can easily affect in one way or another the behavior of the controlled system and, consequently, of the two heat sources. So, whatever the control scheme used, and taking into consideration the specific use of a building, one can promote the set-point tracking performance (i.e. the comfort criterion) while increasing the consumption of fossil energy ($\%_{FE}$) or promote energy savings while decreasing comfort. Promoting I_p is a compromise.

As a conclusion, and taking a look at the dynamic of the controlled system, one can highlight that the PID-MPC scheme anticipates set-point changes and allows, consequently, a better management of the fossil and renewable energy resources, limiting both the number of shutdown and restart sequences and the saturation of the main heat source. Finally, while the best global performance remains PID-MPC's, the PID-FLC is a good compromise between the easy-to-develop but not-very-efficient PID and the efficient but hard-to-develop PID-MPC. Because the three control schemes proposed were only developed in simulation, they need now to be tested using more complex models and/or situations, with the aim of being finally implemented in real buildings.

References

- [1] Official Journal of the European communities, *Directive 2002/91/EC of the European Parliament and the Council of the 16 December 2002 on the energy performance of buildings*, 2002.
- [2] French Environment and Energy Management Agency, *Les chiffres clés du bâtiment en 2006 (Building sector key figures in 2006)*, ADEME publications, 2007.
- [3] Official Journal of French Republic, *decree n°2006-592*, adopted on Mai 24, 2006.
- [4] Official Journal of French Republic, *decree n°2006-1147*, adopted on September 14, 2006.
- [5] A.I. Dounis, C. Caraiscos, *Advanced control systems engineering and comfort management in building environment-A review*, Renewable and Sustainable Energy Reviews 13 (6-7) (2009) 1246-1261.
- [6] E.H. Mathews, D.C. Arndt, C.B. Piani, E. Heerden, *Developing cost efficient control strategies to ensure optimal energy use and sufficient indoor comfort*, Applied Energy 66 (2000) 135-159.
- [7] G.J. Levermore, *Building energy management systems: an application to heating and control*, E & FN SPON, London, 1992.
- [8] C. Bernard, B. Guerrier, M.M. Rasset-Louerant, *Optimal building energy management. Part II: Control*, ASME Journal of Solar Energy Engineering 114 (1982) 13-22.
- [9] D. Kolokotsa, K. Niachou, V. Geros, K. Kalaitzakis, G.S. Stavrakakis, M. Santamouris, *Implementation of an integrated indoor environment and energy management system*, Energy and Buildings 37 (2005) 93-99.
- [10] A.E. Ben-Nakhi, M.A. Mahmoud, *Energy conservation in buildings through efficient A/C control using neural networks*, Applied Energy 73 (2001) 5-23.
- [11] S.A. Kalogirou, M. Bojic, *Artificial neural networks for the prediction of the energy consumption of a passive solar building*, Energy 25 (2000) 479-491.
- [12] P.A. Gonzalez, J.M. Zamarreno, *Prediction of hourly energy consumption in buildings based on a feedback artificial neural network*, Energy and Buildings 37 (2005) 595-601.
- [13] K. Chen, Y. Jiao, E.S. Lee, *Fuzzy adaptive networks in thermal comfort*, Applied Mathematics Letters 19 (5) (2006) 420-426.

- [14] F. Calvino, M.L. Gennusca, G. Rizzo, G. Scaccianoce, *The control of indoor thermal comfort conditions: introducing a fuzzy adaptive controller*, Energy and Buildings 36 (2004) 97-102.
- [15] M. Kummert, P. Andre, J. Nicolas, *Optimal heating control in a passive solar commercial building*, Solar Energy 69 (1-6) (2001) 103-116.
- [16] N. Morel, M. Bauer, M. El-Khoury, J. Krauss, *Neurobat, a predictive and adaptive heating control system using artificial neural networks*, International Journal of Solar Energy 21 (2-3) (2000) 161-201.
- [17] A. Nygard, *Predictive thermal control of building systems*, PhD thesis, Swiss Federal Institute of Technology, Lausanne, Switzerland, 1990.
- [18] P.J. Lute, A.H. Van Paassen, *Optimal indoor temperature control using a predictor*, IEEE Control Systems 12 (1995) 4-9.
- [19] J. Liang, R. Du, *Thermal comfort control based on neural network for HVAC application*, Proceedings of the 2005 IEEE Conference on Control Applications, Toronto, Canada, 819-824, 2005.
- [20] A. Argiriou, C.A. Balaras, I. Bellas, A.I. Dounis, *Use of artificial neural networks for predicting the heating requirements of single family houses*, International Journal of Knowledge-Based Intelligence Engineering Systems 5 (5) (2001) 234-239.
- [21] International Standard, ISO 7730, *Moderate thermal environment-Determination PMV and PPD indices and specifications of the conditions for thermal comfort*, Genève, 1983.
- [22] Official Journal of French Republic, *Decree concerning the Th-CE 2005 index*, adopted on July 19, 2006.
- [23] B. Paris, J. Eynard, G. François, T. Talbert, A. Traoré, F. Thiéry, *Gestion des ressources énergétique d'un bâtiment : contrôle flou (Fuzzy management of energy resources in buildings)*, International Building Performance Simulation Association Conference, Lyon, France, CD-ROM, 2008.
- [24] B. Paris, J. Eynard, G. François, T. Talbert, M. Polit, *A prototype for on line monitoring and control of energy performance for renewable energy buildings*, 5th International Conference on Informatics in Control, Automation and Robotics, Madeira, Portugal, 125-130, 2008.
- [25] B. Paris, J. Eynard, F. Thiéry, A. Traoré, M. Polit, T. Talbert, *Travaux pratiques sur la gestion optimale d'un bâtiment EnR (Practical work about optimal management of renewable-energy buildings)*, J3eA 8 (1) (2009).
- [26] W.L. Luyben, M.L. Luyben, *Essentials of Process Control*, McGraw-Hill, 1997.
- [27] C.E. García, D.M. Prett, M. Morari, *Model predictive control: Theory and practice - A survey*, Automatica 25 (3) (1989) 335-348.
- [28] S.J. Qin, T.A. Badgwell, *A survey of industrial model predictive control technology*, Control Engineering Practice 11 (2003) 733-764.
- [29] L.A. Zadeh, *Fuzzy sets*, Information and Control 8 (1965) 338-353.
- [30] S.R. Huang, C.Y. Lin, C.C. Wu, S.J. Yang, *The application of fuzzy controller for fuel cell generating studies*, International Journal of Hydrogen Energy 33 (19) (2008) 5205-5217.
- [31] A. Traoré, S. Grieu, S. Puig, L. Corominas, F. Thiéry, M. Polit, J. Colprim, *Fuzzy control of dissolved oxygen in a sequencing batch reactor pilot plant*, Chemical Engineering Journal 111 (2005) 13-19.
- [32] A. Traoré, S. Grieu, F. Thiéry, M. Polit, J. Colprim, *Control of sludge height in a secondary settler using fuzzy algorithms*, Computers and Chemical Engineering 30 (2006) 1235-1242.
- [33] C. Wakabayashi, M. Embiruçu, C. Fontes, R. Kalid, *Fuzzy control of a nylon polymerization semi-batch reactor*, Fuzzy Sets and Systems 160 (4) (2009) 537-553.
- [34] A.J. Van der Wal, *Application of fuzzy logic control in industry*, Fuzzy Sets and Systems 74 (1) (1995) 33-41.
- [35] H.B. Verbruggen, P.M. Bruijn, *Fuzzy control and conventional control: What is (and can be) the real contribution of fuzzy systems?*, Fuzzy Sets and Systems 90 (2) (1997) 151-160.
- [36] F. Bouslama, A. Ichikawa, *Fuzzy control rules and their natural control laws*, Fuzzy Sets and Systems 48 (1) (1992) 65-86.