



Vacuum degeneracy of a circuit-QED system in the ultrastrong coupling regime

Pierre Nataf¹ and Cristiano Ciuti^{1,*}

¹Laboratoire Matériaux et Phénomènes Quantiques, Université Paris Diderot-Paris 7 and CNRS, Bâtiment Condorcet, 10 rue Alice Domont et Léonie Duquet, 75205 Paris Cedex 13, France

We investigate theoretically the quantum vacuum properties of a chain of N superconducting Josephson atoms inductively coupled to a transmission line resonator. We derive the quantum field Hamiltonian for such circuit-QED system, showing that, due to the type and strength of the interaction, a quantum phase transition can occur with a twice degenerate quantum vacuum above a critical coupling. In the finite-size case, the degeneracy is lifted, with an energy splitting decreasing exponentially with increasing values of $g^2 N^2$, where g is the dimensionless vacuum Rabi coupling per artificial atom. We determine analytically the ultrastrong coupling asymptotic expression of the two degenerate vacua for an arbitrary number of artificial atoms and of resonator modes. In the ultrastrong coupling regime the degeneracy is protected with respect to random fluctuations of the transition energies of the Josephson elements.

PACS numbers:

Circuit quantum electrodynamics (circuit-QED) is a very fascinating topic for fundamental condensed matter physics, quantum optics and quantum information. In superconducting circuit-QED systems, it has been possible to implement on a chip the celebrated Jaynes-Cummings model by strongly coupling a superconducting artificial atom to a bosonic mode of a microwave transmission line resonator[1, 2] and to perform quantum logical operations with two qubits[3]. So far, experimental manipulation of quantum states in such circuit-QED systems has dealt with excited states. In these systems, the quantum ground state is non-degenerate and no information can be stored or processed by using only the vacuum of the circuit-QED system. In principle, by a judicious choice of their components, superconducting quantum circuits can give rise to Hamiltonians, which cannot be achieved in atomic cavity-QED systems: in particular it may be possible to tailor the relative amplitude and the form of the interaction terms for the generation of interesting and controllable quantum vacuum properties.

Here, we present a rigorous quantum field derivation showing that it is possible to obtain a vacuum degeneracy of a circuit-QED system by using a chain of Josephson junction atoms inductively coupled to a transmission line resonator. A quantum critical coupling occurs in such a circuit-QED system thanks to both the type and ultrastrong size of the interaction obtainable with the inductive coupling scheme. In the case of a finite number N of artificial atoms, a degeneracy lifting occurs, with an energy splitting dramatically decreasing as $\exp(-g^2 \beta(N))$, where g is the dimensionless vacuum Rabi coupling per atom (i.e., vacuum Rabi frequency divided by the transition frequency ω_F) and $\beta(N)$ depends quadratically on N . We present the asymptotic formula of the two degenerate vacua in the ultrastrong coupling limit. Moreover, we show that the degeneracy is protected with respect to random site-dependent fluctuations of the Josephson transition energy.

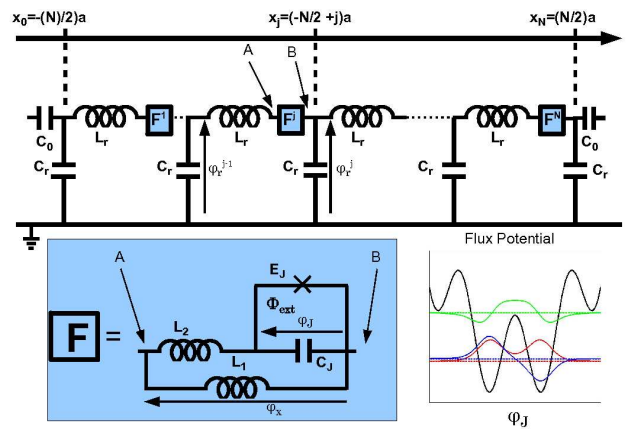

FIG. 1: A chain of N Josephson atoms ("F" stands for fluxonium[4]) are inductively coupled to a transmission line resonator. By tuning the external magnetic flux, the flux-dependent potential for each fluxonium has a symmetric double well structure with two states $|0\rangle$ and $|1\rangle$ (with energy difference $\hbar\omega_F$) forming the two-level system (parameters used for the inset: $E_J/E_{C_J} = 3$, $E_J/E_{L_J} = 20$).

A sketch of the proposed system is depicted in Fig. 1, namely a chain of N identical artificial two-level atoms in a transmission line resonator. Each artificial atom ('fluxonium' [4]) is made of a Josephson junction coupled to inductances and an external magnetic flux. Here, we consider a scheme where each fluxonium is inductively coupled to the resonator. The fluxonium is known to be free from charge offsets[4]; moreover, the inductive coupling can produce extremely large coupling even with a single artificial atom[5]. In the case of a chain, the Hamiltonian is $H = \sum_j H_j$ where each cell of size a is labeled by the index j and is located at the position x_j . One can effectively model the resonator as a sequence of induc-

tances $L_r = al_r$ and capacitances $C_r = ac_r$ [6], where l_r (c_r) is the inductance (capacitance) per unit length. The Hamiltonian of each cell reads:

$$H_j = 4E_{C_r}(\hat{N}_r^{j-1})^2 + \frac{(\hat{\phi}_r^{j-1} - \hat{\phi}_r^j - \hat{\phi}_x^j)^2}{2L_r} + \frac{(\hat{\phi}_x^j)^2}{2L_1} + \frac{(\hat{\phi}_x^j - \hat{\phi}_J^j)^2}{2L_2} + 4E_{C_J}(\hat{N}_J^j)^2 - E_J \cos\left(\frac{2e}{\hbar}(\hat{\phi}_J^j + \Phi_{ext}^j)\right), \quad (1)$$

where \hat{N} and $\hat{\phi}$ are the number and flux operators for the resonator elements and Josephson junctions ('r' stands for resonator; 'J' for Josephson junction). The charging energies are $E_{C_r} = \frac{e^2}{2C_r}$ and $E_{C_J} = \frac{e^2}{2C_J}$. By applying Kirchoff's laws and by taking $\Phi_{ext} = \pi \frac{\hbar}{2e}$, we find $H = H_{res} + H_F + H_{coupling}$, with:

$$H_{res} = \sum_{j=1}^N 4E_{C_r}(\hat{N}_r^j)^2 + E_{L_r} \frac{(\hat{\phi}_r^j - \hat{\phi}_r^{j-1})^2}{2},$$

$$H_F = \sum_{j=1}^N 4E_{C_J}(\hat{N}_J^j)^2 + E_{L_J} \frac{(\hat{\phi}_J^j)^2}{2} + E_J \cos(\hat{\phi}_J^j),$$

$$H_{coupling} = \sum_{j=1}^N G(\hat{\phi}_r^j - \hat{\phi}_r^{j-1})\hat{\phi}_J^j, \quad (2)$$

where we have introduced the dimensionless fluxes $\varphi_r^j = \frac{2e}{\hbar}\hat{\phi}_r^j$, $\varphi_J^j = \frac{2e}{\hbar}\hat{\phi}_J^j$ and the inductance energy constants are $E_{L_r} = \left(\frac{\hbar}{2e}\right)^2 \frac{L_1+L_2}{L_1L_r+L_1L_2+L_2L_r}$, $E_{L_J} = \left(\frac{\hbar}{2e}\right)^2 \frac{L_1+L_r}{L_1L_r+L_1L_2+L_2L_r}$. The magnitude of the coupling constant is $G = \left(\frac{\hbar}{2e}\right)^2 \frac{L_1}{L_1L_r+L_1L_2+L_2L_r}$. The Hamiltonian H_{res} describes the transmission line resonator with a renormalized inductance per unit of length $\tilde{l}_r = l_r \frac{L_1+L_2+\frac{L_2L_1}{al_r}}{L_1+L_2}$, accounting for the additional inductances in each fluxonium. By following the treatment in Ref. [6], the position-dependent flux field is $\hat{\phi}(x) = i \sum_{k \geq 1} \frac{1}{\omega_k} \sqrt{\frac{\hbar\omega_k}{2c_r}} f_k(x) (\hat{a}_k - \hat{a}_k^\dagger)$ where \hat{a}_k^\dagger is the bosonic creation operator of a photon mode with energy $\hbar\omega_k = \frac{k\pi a}{d} \sqrt{8E_{C_r}E_{L_r}}$. The spatial profile of the k -th mode is $f_k(x) = -\sqrt{2/d} \sin(\frac{k\pi x}{d})$ for k odd, while $f_k(x) = \sqrt{2/d} \cos(\frac{k\pi x}{d})$ for k even, d being the length of the one-dimensional resonator (in the following, we will consider $d = Na$). The site-dependent fluxes are simply given by $\hat{\phi}_r^j = \hat{\phi}(x_j)$.

The Hamiltonian H_F describes the sum of the energies of the fluxonium atoms. By properly tuning the external magnetic flux, it is possible to obtain a symmetric flux-dependent potential energy, as shown in Fig. 1, with a double well structure. Due to the strong anharmonicity of its energy spectrum, the fluxonium can be approximated as a two-level system, when $E_J \gg E_{L_J}$. We call the two first eigenstates of the j -th fluxonium as $|0\rangle_j$ and $|1\rangle_j$ and we introduce the raising operator $\hat{\sigma}_{+,j} = |1\rangle\langle 0|_j$ and $\hat{\sigma}_{-,j} = \hat{\sigma}_{+,j}^\dagger = |0\rangle\langle 1|_j$. By using the

Pauli matrix notation, we have $\hat{\sigma}_{x,j} = \hat{\sigma}_{+,j}^\dagger + \hat{\sigma}_{+,j}$ and $\hat{\sigma}_{y,j} = i(\hat{\sigma}_{+,j}^\dagger - \hat{\sigma}_{+,j})$ and $\hat{\sigma}_{z,j} = 2\hat{\sigma}_{+,j}\hat{\sigma}_{+,j}^\dagger - 1$. Leaving aside a constant term, we then have $H_F = \sum_j \hbar\omega_F \frac{1}{2} \hat{\sigma}_{z,j}$, where $\hbar\omega_F$ is the energy difference between the two states $|0\rangle$ and $|1\rangle$. By considering only the two-level subspace, the Josephson junction flux has the form

$$\hat{\varphi}_J^j \simeq \langle 0|\hat{\varphi}_J^j|1\rangle(\hat{\sigma}_{+,j} + \hat{\sigma}_{+,j}^\dagger) = -\varphi_{01}\hat{\sigma}_{x,j}, \quad (3)$$

where $\varphi_{01} \simeq \pi$ for typical parameters (see Fig. 1).

As it will be clear in the following, it is convenient to introduce excitation creation operators $\hat{b}_k^\dagger = \sqrt{\frac{2}{N}} \sum_{j=1}^N \Delta f_k(x_j) \hat{\sigma}_{+,j}$ for $1 \leq k \leq N-1$, where $\Delta f_k(x_j) = \cos(\frac{k\pi(-\frac{N+1}{2}+j)}{d}a)$ for k odd, and $\Delta f_k(x_j) = \sin(\frac{k\pi(-\frac{N+1}{2}+j)}{d}a)$ for k even. Note that the collective operator \hat{b}_k^\dagger is a linear superposition of the excitation operators in each fluxonium with an amplitude depending on the spatial profile of the flux field of the resonator. In order to get a unitary transformation, it is also necessary to introduce the operator $\hat{b}_N^\dagger = \frac{1}{\sqrt{N}} \sum_j (-1)^j \hat{\sigma}_{+,j}$. In the following, we will consider only the resonator modes $1 \leq k \leq N$, because, in the conditions we are considering, the higher order (Bragg) modes are energetically well off-resonant. Hence, we get the following effective Hamiltonian:

$$\mathcal{H} = \frac{\hbar}{2} \sum_{1 \leq k \leq N} \hat{\Phi}_k^\dagger \eta \mathcal{M}_k \hat{\Phi}_k \quad (4)$$

where $\hat{\Phi}_k = (\hat{a}_k, \hat{b}_k, \hat{a}_k^\dagger, \hat{b}_k^\dagger)^T$ with the Bogoliubov diagonal metric $\eta = \text{diag}[1, 1, -1, -1]$, and the matrix:

$$\mathcal{M}_k = \begin{pmatrix} \omega_k & -i\Omega_k & 0 & -i\Omega_k \\ i\Omega_k & \omega_F & -i\Omega_k & 0 \\ 0 & -i\Omega_k & -\omega_k & -i\Omega_k \\ -i\Omega_k & 0 & i\Omega_k & -\omega_F \end{pmatrix}. \quad (5)$$

The coupling between the annihilation operators \hat{a}_k , \hat{b}_k and the creation operators are due to the antiresonant (non-rotating wave) terms present in the coupling Hamiltonian $H_{coupling}$. The collective vacuum Rabi frequency reads for $1 \leq k \leq N-1$

$$\hbar\Omega_k = G \frac{4e}{\hbar} \varphi_{01} \sin\left(\frac{k\pi a}{2d}\right) \frac{1}{\omega_k} \sqrt{\frac{\hbar\omega_k N}{2dc_r}}. \quad (6)$$

(and for $k = N$, $\hbar\Omega_N = G \frac{4e}{\hbar} \frac{\varphi_{01}}{\omega_N} \sqrt{\frac{\hbar\omega_N N}{dc_r}}$).

Notice that each k -mode of the resonator is coupled only to the collective matter mode with the same spatial symmetry and $\mathcal{H} = \sum_k \mathcal{H}_k$. Hence, the eigenstates are products of the eigenstates corresponding to the k -subspaces. The effective Hamiltonian in Eq. (4) has been obtained by assuming that the operators \hat{b}_k^\dagger are bosonic, i.e. $[\hat{b}_k, \hat{b}_k^\dagger] \simeq 1$, an approximation working in

the limit $N \gg 1$. The excitation spectrum of the collective bosonic modes depends on the eigenvalues of the matrix \mathcal{M}_k . A crucial property is given by the determinant $\text{Det}(\mathcal{M}_k) = \omega_k \omega_F (\omega_k \omega_F - 4\Omega_k^2)$, which vanishes when the vacuum Rabi frequency equals the critical value $\Omega_k^c = \frac{\sqrt{\omega_k \omega_F}}{2}$, implying that two of the 4 eigenvalues of \mathcal{M}_k are exactly zero. For $\Omega_k > \Omega_k^c$, two of the 4 eigenvalues of the matrix \mathcal{M}_k becomes imaginary, manifesting an instability of the normal, non-degenerate, quantum vacuum phase.

This is reminiscent of quantum phase transitions[7] with Dicke-like Hamiltonians[8], where at the quantum critical point there is a gapless bosonic excitation. Note that Dicke-like Hamiltonians are usually obtained by dropping the so-called \mathbf{A}^2 -term, that is the term associated to the squared electromagnetic vector potential term [9], [10]. However, because of the magnitude of the \mathbf{A}^2 -term, a system with (ultra)strong light-matter coupling does not necessarily have a quantum critical point[11]. For example, in the celebrated Hopfield model[12] for dielectrics a quantum critical point does not exist even if the coupling can be ultrastrong [13, 14]. In our case, the quantum field Hamiltonian in Eq. (2) is the complete Hamiltonian for the proposed superconducting system and no term has been omitted. In particular, the analogous of the \mathbf{A}^2 term in the present system is given by extra terms proportional to $(\hat{\varphi}_r^j - \hat{\varphi}_r^{j-1})^2$ obtained from Eq. (1) after substitution of the expression for the flux $\hat{\varphi}_x^j$ obtained by Kirchoff's laws[15]. Here, these terms are fully included and contribute to the expression for the resonator renormalized inducting energy E_{L_r} , which does depend on L_1 and L_2 .

For the case of finite number of fluxonium atoms N and finite number of modes N_m , we have performed numerical diagonalizations of the circuit-QED Hamiltonian. As shown in Fig. 2, for increasing coupling the energy of the first excited state converges towards the energy of the ground state, hence a twice degenerate vacuum is obtained in the ultrastrong coupling limit. As shown in the inset, for a given value of N , the energy splitting exponentially decreases with increasing vacuum Rabi coupling. The finite-size scaling properties are shown in Fig. 3(a), where the energy splitting is plotted as a function of g^2 , where $g = \frac{\Omega_{k=1}}{\sqrt{N}\omega_{k=1}}$ is the dimensionless vacuum Rabi coupling per fluxonium. Our numerical results show that the energy splitting scales $\exp(-g^2\beta(N))$, where $\beta(N) \approx 2N^2$ (see inset of Fig. 3a). Hence, a perfect degeneracy is obtained either in the thermodynamical limit ($N \rightarrow +\infty$) or for $g \gg 1$. As shown later, it is possible to have $g \gg 1$ in realistic superconducting systems, hence a negligible splitting can be achieved with a relatively small N . In the ultrastrong coupling limit ($\frac{\Omega_{k=1}}{\omega_F} \rightarrow \infty$), we have derived[16] an analytical expression for the two degenerate ground states by taking

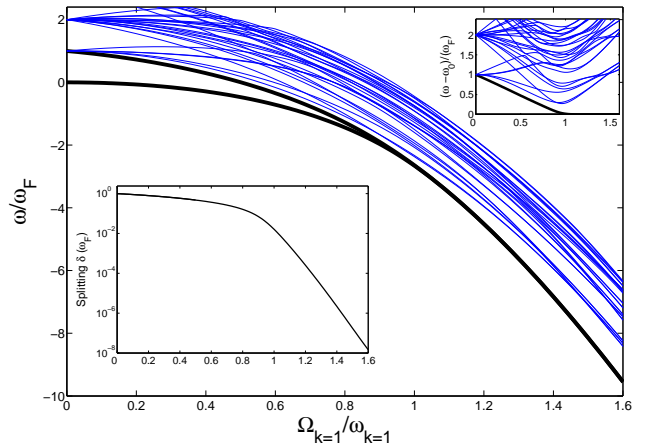

FIG. 2: First 30 energy eigenvalues versus dimensionless vacuum Rabi coupling for $N = 5$ fluxonium atoms, $N_m = 3$ resonator modes ($\omega_F = \omega_{k=1}$). Upper inset: the difference between the energy eigenvalues and the ground state energy is plotted. Lower inset: normalized energy difference (log scale) between the first 2 quasi-degenerate levels versus the dimensionless coupling. In the ultrastrong coupling limit, the two ground states are excellently approximated by the analytical formula in Eq. (7) (98% overlap for the largest coupling here considered).

into account an arbitrary number N_m of modes for the resonator. It is convenient to introduce the x -polarized states (eigenstates of $\hat{\sigma}_{x,j}$), namely $|+\rangle_j = \frac{1}{\sqrt{2}}(|1\rangle_j + |0\rangle_j)$ and $|-\rangle_j = \frac{1}{\sqrt{2}}(|1\rangle_j - |0\rangle_j)$. We have found that in the ultrastrong coupling limit (where H_F is dominated by $H_{res} + H_{coupling}$) the asymptotic expression for the two degenerate vacua $|G_+\rangle$ and $|G_-\rangle$ is:

$$|G_{\pm}\rangle = C_G \Pi_j |\pm\rangle_j \otimes \Pi_{k_o} e^{\pm i \frac{g\sqrt{2}}{k_o^{1.5} \sin(\frac{k_o}{2N})} a_{k_o}^\dagger} |0\rangle_{k_o} \otimes \Pi_{k_e} |0\rangle_{k_e} \quad (7)$$

with C_G a normalisation constant, k_o (k_e) standing for the odd (even) k values for the resonator modes. Eq. (7) shows that the two degenerate ground states are the product of a 'ferromagnetic' state for the chain of artificial atoms times coherent states for the different resonator modes. Importantly, the two orthogonal ground states have opposite polarization of the pseudospins and opposite phases for the coherent states. Due to the mode spatial symmetry, in $|G_{\pm}\rangle$ the even k_e resonator modes are empty. The analytical expression for the two vacua excellently agrees with the numerical results.

It is interesting to see how the degeneracy is affected by the presence of an additional Hamiltonian term $H_{pert} = \sum_j \frac{1}{2} \hbar \Delta_j \hat{\sigma}_{z,j}$, describing a site-dependent random fluctuation of the fluxonium energies. Interestingly, we have found numerically (see Fig. 3b) and analytically[16] that the average splitting $\langle \delta \rangle$ and its standard deviation $\sigma = \sqrt{\langle \delta^2 \rangle - \langle \delta \rangle^2}$ have the same expo-

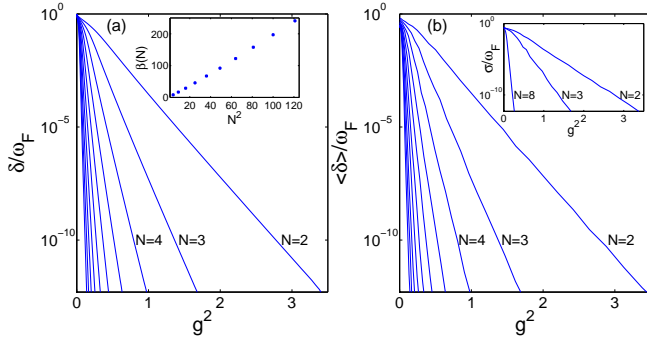

FIG. 3: Normalized energy splitting (log scale) between the two quasi-degenerate vacua versus g^2 for different values of N (2,3,4,...11), where g is the dimensionless vacuum Rabi coupling frequency per artificial atom. (a) Results for the case of identical fluxonium atoms with same transition frequency ω_F . δ/ω_F decreases as $\exp(-\beta(N)g^2)$. Inset: $\beta(N)$ versus N^2 . (b) Averaged splitting $\langle \delta \rangle$ in presence of a random distribution: $\omega_{j,F} = \omega_F + \Delta_j = \omega_F(1 + 0.5\xi_j)$, where j labels the site and ξ_j is a gaussian variable with variance equal to 1. The results have been averaged over 100 disorder configurations. The standard deviation $\sigma = \sqrt{\langle \delta^2 \rangle - \langle \delta \rangle^2}$ has the same exponential dependence (see inset).

nential dependence as the splitting in the ideal case of identical Josephson elements. By having N and/or g large enough, the effect of a disorder of given amplitude can be made arbitrary small. This occurs because $\langle G_{\pm} | H_{pert}^m | \hat{G}_{\pm} \rangle = \langle G_{\pm} | H_{pert}^m | G_{\mp} \rangle = 0$ with $m \leq N - 1$, i.e., such a perturbation is zero up to the N -th order perturbation theory, leading to a protected degeneracy[17].

The present system can indeed have a very large controllable coupling. For $\omega_F = \omega_{k=1}$, we have

$$\frac{\Omega_{k=1}}{\omega_{k=1}} = g\sqrt{N} = \sqrt{\frac{Z_{vac}}{2Z_r\alpha}} \mu\nu\chi\sqrt{N} \sim 5.7\chi\sqrt{N}, \quad (8)$$

where $\nu = \frac{1}{4\pi}\varphi_{01} \sim \frac{1}{4}$ for $\frac{E_J}{E_{L,J}} \gg 1$, $\mu = \frac{\sin(\frac{\pi a}{2d})}{\frac{\pi a}{2d}}$. For $\frac{a}{d} \rightarrow 0^+$, we have $\mu \sim 1$. Moreover, $\frac{Z_{vac}}{2\alpha} = \frac{\hbar}{c^2} = R_k \sim 25.8k\Omega$ is the impedance quantum, while $Z_r = \sqrt{\frac{L_r}{C_r}} = 50\Omega$ is the standard transmission line impedance. Finally, the branching ratio $\chi = \left(\frac{L_r}{L_1L_r + L_1L_2 + L_2L_r}\right)^{\frac{1}{4}} \frac{L_1}{(L_1 + L_2)^{\frac{3}{4}}}$ is the control parameter to tune $\frac{\Omega_{k=1}}{\omega_{k=1}}$. $\chi \simeq 0$ for $L_1 \ll L_2$ and $\chi \simeq 1$ when $\frac{L_1}{L_2} \gg 1$.

Note that the bosonic mode population in the ground state cannot give rise to any extracavity microwave radiation unless a non-adiabatic modulation of the Hamiltonian is applied[13, 14, 18]. The quantum vacuum radiation across the quantum phase transition is an interesting problem to explore in the future. In the opposite

limit of adiabatic changes of the Hamiltonian, thanks to the degeneracy, it may be possible to create non-abelian Berry phases and control quantum superpositions in the ground state subspace (a sort of vacuum qubit). The system studied here appears promising for the observation of quantum phase transitions and the manipulation of quantum vacua in circuit-QED.

We are grateful to M.H. Devoret for many discussions and for suggesting us to consider the fluxonium atom. We thank B. Douçot, I. Carusotto, S. De Liberato for discussions and M. Bamba for numerical advice.

* E-mail: cristiano.ciuti@univ-paris-diderot.fr

- [1] A. Wallraff *et al.*, Nature **431**, 162 (2004).
- [2] L. S. Bishop *et al.*, Nature Phys. **5**, 105 (2009)
- [3] L. DiCarlo *et al.*, Nature **460**, 240 (2009).
- [4] V. E. Manucharyan, J. Koch, L.I. Glazman, M.H. Devoret, Science **326**, 113 (2009).
- [5] M.H. Devoret, S.M. Girvin, and R.J. Schoelkopf, Ann. Phys. **16**, 767 (2007).
- [6] A. Blais *et al.*, Phys. Rev. A **69**, 062320 (2004).
- [7] See, e.g., Subir Sachdev, *Quantum Phase Transitions*, (Cambridge University Press, 2001).
- [8] C. Emary, T. Brandes, Phys. Rev. Lett. **90**, 044101 (2003) and Phys. Rev. E **67**, 066203 (2003).
- [9] Neill Lambert, Yueh-nan Chen, Robert Johansson, and Franco Nori, Phys. Rev. B **80**, 165308 (2009).
- [10] F. Dimer, B. Estienne, A. S. Parkins, and H. J. Carmichael, Phys. Rev. A **75**, 013804 (2007).
- [11] In the case of the Hopfield model [12], the excitations are given by the eigenvalues of a matrix of the form

$$\mathcal{M}_k^{\text{Hopfield}} = \begin{pmatrix} \omega_k + 2D_k & -i\Omega_k & -2D_k & -i\Omega_k \\ i\Omega_k & \omega_{12} & -i\Omega_k & 0 \\ 2D_k & -i\Omega_k & -\omega_k - 2D_k & -i\Omega_k \\ -i\Omega_k & 0 & i\Omega_k & -\omega_{12} \end{pmatrix},$$

where ω_{12} is the two-level transition frequency, Ω_k is the vacuum Rabi coupling (proportional to the electric dipole matrix element) and D_k is a term arising from the square vector potential in the light-matter interaction. In the Hopfield matrix[12], $D_k = \Omega_k^2/\omega_{12}$ and $\text{Det}(\mathcal{M}_k^{\text{Hopfield}}) = (\omega_k\omega_{12})^2 \neq 0$ and no quantum critical point exists, even if the coupling can be ultrastrong[13, 14].

- [12] J. J. Hopfield, Phys. Rev. **112**, 1555 (1958).
- [13] C. Ciuti, G. Bastard, I. Carusotto, Phys. Rev. B **72**, 115303 (2005)
- [14] C. Ciuti, I. Carusotto, Phys. Rev. A **74**, 033811 (2006).
- [15] Imposing the current conservation, one finds $\hat{\phi}_x^j = \frac{L_1L_2}{L_1L_2 + L_1L_r + L_rL_2}(\hat{\phi}_r^{j-1} - \hat{\phi}_r^j) + \frac{L_1L_r}{L_1L_2 + L_1L_r + L_rL_2}\hat{\phi}_J^j$.
- [16] See supplementary material.
- [17] B. Douçot, M. V. Feigel'man, L. B. Ioffe, and A. S. Ioselevich, Phys. Rev. B **71**, 024505 (2005)
- [18] S. De Liberato, C. Ciuti, I. Carusotto, Phys. Rev. Lett. **98**, 103602 (2007); S. De Liberato *et al.*, Phys. Rev. A **80**, 053810 (2009).

**SUPPLEMENTARY ONLINE MATERIAL FOR THE PAPER : VACUUM DEGENERACY OF A
CIRCUIT-QED SYSTEM IN THE ULTRA-STRONG COUPLING REGIME**

In Section A of this Supplementary Material, we give a detailed proof of our analytical expression for the two degenerate vacua in the ultrastrong coupling regime. In Section B, we show the analytical calculation of the degeneracy splitting in the ultrastrong coupling limit. We show also useful details about the degeneracy with respect to site-dependent fluctuations of the Josephson atom transition frequencies (energy disorder).

A. ULTRA-STRONG COUPLING LIMIT: ANALYTICAL APPROACH

Let us consider the ultrastrong coupling limit ($\frac{\Omega_{k=1}}{\omega_F} \rightarrow +\infty$), by taking into account an arbitrary number of modes N_m for the transmission line resonator and a finite number N of fluxoniums qubits. The following treatment is general and can be done for any kind of mode spatial profile $\Delta f_k(x)$. In the ultra-strong coupling regime, the bare Hamiltonian H_F of the pseudospins (the Josephson artificial atoms) can be treated as a perturbation of the Hamiltonian $H_{res} + H_{coupling}$, where H_{res} is the Hamiltonian of the bare transmission line and $H_{coupling}$ is the interaction part between the resonator and the artificial atoms. As written in the letter, it is convenient to consider the basis $(|-\rangle, |+\rangle)_j$, the two eigenvectors of the operator $\hat{\sigma}_{x,j}$. The Hamiltonian can be rewritten in the form:

$$H_{res} + H_{coupling} = \sum_{k=1..N_m} \hbar\omega_k a_k^\dagger a_k + \sum_{k=1..N_m} \sum_{j=1}^N i\hbar\Omega_k \sqrt{\frac{2}{N}} \Delta f_k(x_j) (a_k - a_k^\dagger) (|+\rangle\langle +|_j - |-\rangle\langle -|_j) \quad (9)$$

Let us introduce the subspace \mathcal{F}_{S_ζ} generated by the states $\Pi_j |\zeta_j\rangle \otimes |\Psi_{res}\rangle$ where the $\zeta_j \in \{-, +\}$ denote a given pseudospin configuration sequence S_ζ for the chain, while $|\Psi_{res}\rangle$ describes a generic state of the resonator bosonic quantum field. Since there are N two-level systems, then we have 2^N subspaces $\mathcal{F}_{\{\zeta_j\}_{j=1..N}}$, each for every pseudospin configuration.

It is clear that by applying $H_{res} + H_{coupling}$ on a state $|\psi\rangle \in \mathcal{F}_{\{\zeta_j\}_{j=1..N}}$, the result is a state belonging to the same subspace (i.e., $H_{res} + H_{coupling}$ conserves a given pseudospin configuration). Now, if we consider a given pseudospin configuration sequence S_ζ for the chain, we can define $\psi_k^{S_\zeta} = \sum_j \sqrt{\frac{2}{N}} \Delta f_k(x_j) \mu_{S_\zeta}(j)$ where $\mu_{S_\zeta}(j) = 1$ if $|S_{\zeta_j}\rangle = |+\rangle_j$ and where $\mu_{S_\zeta}(j) = -1$ if $|S_{\zeta_j}\rangle = |-\rangle_j$, we have that the Hamiltonian on the (\mathcal{F}_{S_ζ}) can be written as:

$$H_{res}^{S_\zeta} + H_{coupling}^{S_\zeta} = \sum_{k=1..N_m} (\hbar\omega_k a_k^\dagger a_k + i\hbar\Omega_k (a_k - a_k^\dagger) \psi_k^{S_\zeta}) = \sum_{k=1..N_m} (\hbar\omega_k (a_k^\dagger + i\frac{\Omega_k}{\omega_k} \psi_k^{S_\zeta}) (a_k - i\frac{\Omega_k}{\omega_k} \psi_k^{S_\zeta}) - \hbar\frac{\Omega_k^2}{\omega_k} (\psi_k^{S_\zeta})^2). \quad (10)$$

So if we introduce the shifted boson operator $\tilde{a}_k^{S_\zeta} = a_k - i\frac{\Omega_k}{\omega_k} \psi_k^{S_\zeta}$, we have the same bosonic commutation relations between $a_k^{S_\zeta}$ and $(\tilde{a}_k^{S_\zeta})^\dagger$ and the Hamiltonian terms read

$$H^{S_\zeta} = \sum_{k=1..N_m} \hbar\omega_k (\tilde{a}_k^{S_\zeta})^\dagger \tilde{a}_k^{S_\zeta} - \sum_{k=1..N_m} \hbar\frac{\Omega_k^2}{\omega_k} (\psi_k^{S_\zeta})^2 \quad (11)$$

So, on this subspace, the fundamental state $|G_{S_\zeta}\rangle$ has the energy $E_{G_{S_\zeta}} = -\sum_{k=1..N_m} \hbar\frac{\Omega_k^2}{\omega_k} (\psi_k^{S_\zeta})^2$. Moreover, we have:

$$\tilde{a}_k^{S_\zeta} |G_{S_\zeta}\rangle = 0 \quad \forall k \leq N_m$$

This relation implies that:

$$|G_{S_\zeta}\rangle = \Pi_j |S_{\zeta_j}\rangle \otimes \Pi_k e^{-\frac{(\frac{\Omega_k}{\omega_k} \psi_k^{S_\zeta})^2}{2}} e^{(i\frac{\Omega_k}{\omega_k} \psi_k^{S_\zeta} a_k^\dagger)} |0\rangle_k \quad (12)$$

In order to find the ground state for the complete Hilbert space, we have to determine the pseudospin configuration minimizing $-\sum_{k=1..N_m} \hbar\frac{\Omega_k^2}{\omega_k} (\psi_k^{S_\zeta})^2 = -2g^2(\hbar\omega_{k=1}) \sum_{j,j'} \mu_{S_\zeta}(j) Q(j, j') \mu_{S_\zeta}(j')$ where $g = \frac{\Omega_{k=1}}{\sqrt{N}\omega_{k=1}}$ and where we have called Q the quadratic form

$$Q(j, j') = \sum_{k=1..N_m} \Delta f_k(x_j) [(\frac{\Omega_k}{\omega_{k=1}})^2 \frac{1}{k}] \Delta f_k(x_{j'}).$$

For a given number of modes N_m and a given spatial profile $\Delta f_k(x)$ and position $(x_j)_{j=1..N}$, we derive the form and we find beyond the 2^N configurations S_ζ , the one which minimizes $-\sum_{j,j'} \mu_{S_\zeta}(j) Q(j,j') \mu_{S_\zeta}(j')$. In fact the double degeneracy of the spectrum appears also here because at any configuration S_ζ corresponds, an opposite one $S_{\zeta'}$ (for which $\mu_{S_{\zeta'}}(j) = -\mu_{S_\zeta}(j) \quad \forall j$) with same energy. With our particular profile, the configurations of minimal energy are the two ferro-magnetic ones: $\mu_{S_\zeta}(j) = +1 \quad \forall j$ and $\mu_{S_{\zeta'}}(j) = -1 \quad \forall j$. So, to conclude, the two fundamental states we derived are :

$$|G_\pm\rangle = \Pi_j |\pm\rangle \otimes \Pi_k e^{-\frac{(\frac{\Omega_k}{\omega_k} \psi_k^{S_\pm})^2}{2}} e^{(i\frac{\Omega_k}{\omega_k} \psi_k^{S_\pm} a_k^\dagger)} |0\rangle_k = C_G \Pi_j |\pm\rangle_j \otimes \Pi_{k_o} e^{\pm(i\frac{g\sqrt{2}}{k_o^{1.5} \sin(\frac{\pi}{2N})} a_{k_o}^\dagger)} |0\rangle_{k_o} \otimes \Pi_{k_e} |0\rangle_{k_e} \quad (13)$$

where $C_G = \Pi_{k_o} e^{-\frac{(\frac{g\sqrt{2}}{k_o^{1.5} \sin(\frac{\pi}{2N})})^2}{2}}$ and with k_o (k_e) standing for the odd k values for the resonator modes.

B: DEGENERACY SPLITTING AND PROTECTION WITH RESPECT TO SITE-DEPENDENT ENERGY DISORDER IN THE ULTRA-STRONG COUPLING LIMIT

Now let us consider the effect of the bare Hamiltonian for the artificial atoms, namely $H_F = \hbar\omega_F \sum_{j=1}^N \frac{1}{2} \hat{\sigma}_{z,j} = \hbar\omega_F \sum_{j=1}^N \frac{1}{2} (|+\rangle\langle-|_j + |- \rangle\langle+|_j)$, where $|\pm\rangle_j$ are the eigenstates of $\hat{\sigma}_{x,j}$. In the ultrastrong coupling limit, H_F acts as a perturbation of $H_{res} + H_{coupling}$. In the finite-size case, this produces a degeneracy splitting for the two vacua $|G_+\rangle$ and $|G_-\rangle$. In presence of N artificial atoms, the effect of H_F is zero up to the N -th order in perturbation theory. As shown by the numerical results reported in our letter, the splitting decreases as $\sim e^{-\beta(N)g^2}$ with $\beta(N) \approx 2N^2$ (see inset of Fig. 3a). Here we show in detail for the case $N = 2$ that this exponential dependence can be found analytically. Moreover, the same result occurs in presence of a random site-dependent fluctuation of the artificial atom transitions energies (energy disorder). We finally discuss the $N \geq 2$ case.

Degeneracy splitting for $N=2$ fluxoniums in the ultrastrong coupling limit

Let us consider the term $\hbar\omega_F \frac{1}{2} (|+\rangle\langle-|_1 + |- \rangle\langle+|_1)$, that is the bare Hamiltonian term associated to the first artificial atom. Taken alone, such a term does not lift the degeneracy since it does not couple directly $|G_+\rangle$ and $|G_-\rangle$ at any order. However, it produces a mixing of the vacuum states $|G_+\rangle$ and $|G_-\rangle$ with the excited states of $H_{res} + H_{coupling}$. Accordingly, we can introduce the following states

$$|\tilde{G}_+\rangle \simeq |G_+\rangle + \frac{1}{2} \hbar\omega_F \sum_{\mathbf{n}} \frac{\langle \mathbf{n}, - + | \sigma_1^z | G_+\rangle}{E_{G_+} - E_{\mathbf{n}, - +}} |\mathbf{n}, - +\rangle \quad (14)$$

$$|\tilde{G}_-\rangle \simeq |G_-\rangle + \frac{1}{2} \hbar\omega_F \sum_{\mathbf{n}} \frac{\langle \mathbf{n}, + - | \sigma_1^z | G_-\rangle}{E_{G_-} - E_{\mathbf{n}, + -}} |\mathbf{n}, + -\rangle, \quad (15)$$

where $\mathbf{n} = (n_1, n_2, \dots, n_{N_m})$ and the states $|\mathbf{n}, - +\rangle = \frac{1}{\sqrt{n_1! \dots n_{N_m}!}} ((\tilde{a}_{k=1}^-)^{\dagger})^{n_1} \dots ((\tilde{a}_{k=N_m}^-)^{\dagger})^{n_{N_m}} |G_{-+}\rangle$ stand for the excited eigenstates of $H_{res} + H_{coupling}$ with pseudospin configuration $\{-+\}$. Their corresponding eigenenergies are $E_{\mathbf{n}, - +} = \sum_{k=1, \dots, N_m} n_k \hbar\omega_k + E_{G_{-+}}$. They are obtained by applying the shifted photonic creation operators $(\tilde{a}_k^-)^{\dagger} = a_k^\dagger + i\frac{\Omega_k}{\omega_k} \psi_k^-$ for the mode numbers $k = 1$ to $k = N_m$. Analogous definition holds for $|\mathbf{n}, + -\rangle$, corresponding to the pseudospin configuration $\{+-\}$.

Now, we can take care of $\hbar\omega_F \frac{1}{2} \sigma_2^z = \hbar\omega_F \frac{1}{2} \sigma_2^z (|+\rangle\langle-|_2 + |- \rangle\langle+|_2)$, that is the contribution of the second pseudospin. The energy splitting between the vacua $|G_+\rangle$ and $|G_-\rangle$ at the $N = 2$ order perturbation theory is

$$\begin{aligned} \delta = \omega_F \langle \tilde{G}_- | \sigma_2^z | \tilde{G}_+\rangle &= \frac{\omega_F}{2} \left(\sum_{\mathbf{n}} \frac{\hbar\omega_F \langle G_+ | \sigma_2^z | \mathbf{n}, + -\rangle \langle \mathbf{n}, + - | \sigma_1^z | G_-\rangle}{E_{G_+} - E_{\mathbf{n}, + -}} + \sum_{\mathbf{n}} \frac{\hbar\omega_F \langle G_- | \sigma_2^z | \mathbf{n}, - +\rangle \langle \mathbf{n}, - + | \sigma_1^z | G_+\rangle}{E_{G_-} - E_{\mathbf{n}, - +}} \right) \\ &= \omega_F \sum_{\mathbf{n}} \frac{\hbar\omega_F \langle G_+ | \sigma_2^z | \mathbf{n}, + -\rangle \langle \mathbf{n}, + - | \sigma_1^z | G_-\rangle}{E_{G_-} - E_{\mathbf{n}, + -}}. \end{aligned} \quad (16)$$

We can now consider the effect of only one photonic mode ($N_m = 1$). In that case, the result is simplified because $\psi_{k=1}^- = -\Delta f_{k=1}(x_1) + \Delta f_{k=1}(x_2) = 0$, hence the excited states $|\mathbf{n}, + -\rangle$ are simply the unshifted Fock states $|n\rangle$.

Then, the energy splitting reads:

$$\begin{aligned}\delta &\simeq \frac{\omega_F^2}{\omega_{k=1}} C_G^2 \sum_n \frac{\langle 0 | e^{-2gia_{k=1}} | n \rangle \langle n | e^{-2gia_{k=1}^\dagger} | 0 \rangle}{4g^2 + n} \\ &= \frac{\omega_F^2}{\omega_{k=1}} e^{-4g^2} \sum_n \frac{(-4g^2)^n}{(4g^2 + n)n!} \simeq \frac{\omega_F^2}{2\omega_{k=1}} \sqrt{\frac{\pi}{2g^2}} e^{-8g^2}.\end{aligned}\quad (17)$$

In the last derivation we used the identity $\psi_{k=1}^{++} = \Delta f_{k=1}(x_1) + \Delta f_{k=1}(x_2) = \sqrt{2} = -\psi_{k=1}^{--}$ and $E_{G_+} = E_{G_-} = -4\hbar\omega_{k=1}g^2$. Note that we have verified that this analytical expression is an excellent approximation of the exact numerical results (for the parameters used in the figures of our manuscript the analytical approximation differs less than 10% from the numerical results).

Degeneracy splitting for $N = 2$ in presence of site-dependent energy disorder in the ultrastrong coupling limit

Now, we wish to consider a configuration where the artificial atoms have not the same energy. In Fig. 3b of our manuscript, we have reported numerical results showing that a disorder-induced degeneracy splitting dramatically decreases with the coupling per fluxonium g and size N . In particular, we have shown that there is the same exponential dependence as in the absence of disorder. This can be proved analytically for the $N = 2$ case. We consider

$$H_F = \sum_{j=1,2} \hbar\omega_{F,j} \frac{1}{2} \hat{\sigma}_{z,j} \quad (18)$$

Following the same steps as in the previous derivation we find:

$$\delta \simeq \omega_{F,2} \sum_{\mathbf{n}} \frac{\hbar\omega_{F,1} \langle G_+ | \sigma_2^z | \mathbf{n}, +- \rangle \langle \mathbf{n}, +- | \sigma_1^z | G_- \rangle}{E_{G_-} - E_{\mathbf{n},+-}} \simeq \frac{\omega_{F,2}}{2} \frac{\omega_{F,1}}{\omega_{k=1}} \sqrt{\frac{\pi}{2g^2}} e^{-8g^2}.\quad (19)$$

If we now consider different disorder realizations and we average over the configurations, we get an average splitting:

$$\langle \delta \rangle \simeq \frac{\langle \omega_{F,1}\omega_{F,2} \rangle}{2\omega_{k=1}} \sqrt{\frac{\pi}{2g^2}} e^{-8g^2}.\quad (20)$$

Taking $\omega_{F,i} = \omega_F + \Delta_i$ with Δ_i a random variable with zero average ($\langle \Delta_j \rangle = 0$), variance $\langle \Delta_i^2 \rangle = \Delta^2$ and such that $\langle \Delta_i \Delta_{j \neq i} \rangle = 0 \quad \forall i, j$, then the averaged degeneracy splitting $\langle \delta \rangle$ and the standard deviation σ read:

$$\langle \delta \rangle \simeq \frac{\omega_F^2}{2\omega_{k=1}} \sqrt{\frac{\pi}{2g^2}} e^{-8g^2},\quad (21)$$

$$\sigma = \sqrt{\langle \delta^2 \rangle - \langle \delta \rangle^2} \simeq \sqrt{2 + \left(\frac{\Delta}{\omega_F}\right)^2} \frac{\Delta}{\omega_F} \langle \delta \rangle.\quad (22)$$

Hence, the averaged splitting is equal to the splitting without disorder for the case of identical Josephson elements. The standard deviation of the splitting depends on the normalized disorder amplitude Δ/ω_F , but it has the same exponential dependence as $\langle \delta \rangle$. Hence, in the ultrastrong coupling limit ($g \gg 1$), the effect of disorder can be made arbitrarily small.

Note that a similar protection occurs with respect to local noise sources proportional to $\hat{\sigma}_{y,j}$.

Degeneracy splitting for $N \geq 2$ fluxoniums

We now consider the general case $N \geq 2$ and Josephson artificial atoms with site-dependent energy, i.e. $H_F = \sum_{j=1..N} \hbar\omega_{F,j} \frac{1}{2} \hat{\sigma}_{z,j}$. In this general case, H_F couples the two degenerate vacua only at the N -th order in perturbation theory. For finite values of N and g , the energy splitting is given by the following expression:

$$\hbar\delta \simeq 2 \left[\prod_{j=1..N} \left(\frac{\omega_{F,j}}{2\omega_{k=1}} \right) \right] \left| \sum_{\sigma \in \mathfrak{S}_N} \sum_{\mathbf{n}_1, \mathbf{n}_2, \dots, \mathbf{n}_{N-1}} \right| \quad (23)$$

$$\frac{\langle G_+ | \sigma_{\sigma(1)}^z | \mathbf{n}_1, \sigma(1)(S_+) \rangle \langle \mathbf{n}_1, \sigma(1)(S_+) | \sigma_{\sigma(2)}^z | \mathbf{n}_2, \sigma(2)(\sigma(1)(S_+)) \rangle \dots \langle \mathbf{n}_{N-1}, \sigma(N-1)(\dots\sigma(1)(S_+)) | \sigma_{\sigma(N)}^z | G_- \rangle}{(E_{G_+} - E_{\mathbf{n}_1, \sigma(1)(S_+)}) (E_{\mathbf{n}_1, \sigma(1)(S_+)} - E_{\mathbf{n}_2, \sigma(2)(\sigma(1)(S_+))}) \dots (E_{\mathbf{n}_{N-2}, \sigma(N-2)(\dots\sigma(1)(S_+))} - E_{\mathbf{n}_{N-1}, \sigma(N-1)(\dots\sigma(1)(S_+)})})}, \quad (24)$$

where \mathfrak{S}_N is the set of permutations of $\{1..N\}$, S_+ is the $\{+ + \dots +\}$ configuration, and where $\sigma(m)(\dots\sigma(1)(S_+))$ stands for the pseudo-spin configuration in which the $\sigma(1)^{th}$, $\sigma(2)^{th}$... $\sigma(m)^{th}$ pseudo-spins have switched from $+$ to $-$. The last expression contains all the excited states of every pseudo-spin configurations, with their energies at the denominator. In fact, in the ultrastrong coupling limit, the denominator will give a polynomial contribution to the splitting proportional to $(\hbar\omega_{k=1})^{N-1}$. Hence, we get

$$\delta \sim 2\omega_{k=1} \left[\prod_{j=1..N} \left(\frac{\omega_{F,j}}{2\omega_{k=1}} \right) \right] \sum_{\sigma \in \mathfrak{S}_N} \sum_{\mathbf{n}_1, \mathbf{n}_2, \dots, \mathbf{n}_{N-1}} \quad (25)$$

$$\begin{aligned} & \langle G_+ | \sigma_{\sigma(1)}^z | \mathbf{n}_1, \sigma(1)(S_+) \rangle \langle \mathbf{n}_1, \sigma(1)(S_+) | \sigma_{\sigma(2)}^z | \mathbf{n}_2, \sigma(2)(\sigma(1)(S_+)) \rangle \dots \langle \mathbf{n}_{N-1}, \sigma(N-1)(\dots\sigma(1)(S_+)) | \sigma_{\sigma(N)}^z | G_- \rangle \\ &= 2\omega_{k=1} N! \left[\prod_{j=1..N} \left(\frac{\omega_{F,j}}{2\omega_{k=1}} \right) \right] \langle G_+ | \prod_{j=1..N} \sigma_{\sigma(j)}^z | G_- \rangle = 2\omega_{k=1} N! \left[\prod_{j=1..N} \left(\frac{\omega_{F,j}}{2\omega_{k=1}} \right) \right] \langle G_+ | \prod_{j=1..N} \sigma_j^z | G_- \rangle \\ &= 2\omega_{k=1} N! \left[\prod_{j=1..N} \left(\frac{\omega_{F,j}}{2\omega_{k=1}} \right) \right] e^{\frac{-4g^2}{\sin(\frac{\pi}{2N})^2} \sum_{1 \leq k_e \leq N_m} \frac{1}{k_e^3}} \quad (26) \end{aligned}$$

The averaged degeneracy splitting $\langle \delta \rangle$ and the standard deviation σ over the disorder configurations read:

$$\langle \delta \rangle \sim 2\omega_{k=1} N! \left(\frac{\omega_F}{2\omega_{k=1}} \right)^N e^{\frac{-4g^2}{\sin(\frac{\pi}{2N})^2} \sum_{1 \leq k_e \leq N_m} \frac{1}{k_e^3}} \quad (27)$$

$$\sigma = \sqrt{\langle \delta^2 \rangle - \langle \delta \rangle^2} \sim 2\omega_{k=1} N! \left(\frac{\omega_F}{2\omega_{k=1}} \right)^N e^{\frac{-4g^2}{\sin(\frac{\pi}{2N})^2} \sum_{1 \leq k_e \leq N_m} \frac{1}{k_e^3}} \sqrt{\left(1 + \left(\frac{\Delta}{\omega_F} \right)^2 \right)^N - 1} \sim \sqrt{N} \frac{\Delta}{\omega_F} \langle \delta \rangle$$

So, at resonance, and keeping only the dominant term,

$$\log \left(\frac{\langle \delta \rangle}{\omega_F} \right) = -\beta(N)g^2 \sim \frac{-4g^2}{\sin(\frac{\pi}{2N})^2} \sum_{1 \leq k_e \leq N_m} \frac{1}{k_e^3} \quad (28)$$

where $1.6N^2 < \frac{4}{\sin(\frac{\pi}{2N})^2} \sum_{1 \leq k_e \leq N_m} \frac{1}{k_e^3} < 2.1N^2 \quad \forall N \geq 2$, which agrees with the numerical results .

The standard deviation σ of the degeneracy splitting does depend on the normalized disorder amplitude Δ/ω_F , but it has the same exponential dependance than the average splitting δ . Hence, the effect of disorder can be made arbitrarily small when g and/or N are large enough.