

# Game-Theoretic Techniques for Intelligent Wireless Networks

Gaoning He  
Motorola Labs & Télécom  
ParisTech  
91193 Gif sur Yvette, France  
gaoning.he@gmail.com

Mérouane Debbah  
Alcatel-Lucent Chair in  
Flexible Radio & Supélec  
91193 Gif sur Yvette, France  
merouane.debbah@supelec.fr

Eitan Altman  
INRIA  
06902 Sophia Antipolis,  
France  
altman@sophia.inria.fr

## ABSTRACT

To cope with the fast development of decentralized wireless communications, game theory has been considered as a necessary and powerful mathematical tool to study the competition and cooperation between future intelligent wireless devices. This paper surveys the state-of-the-art of game-theoretical tools applied to wireless communications, focusing mainly on the analysis of wireless resource allocation problems.

## 1. INTRODUCTION

It has been nearly one and half century since the invention of wireless transmission using electromagnetic spectrum. From the early use of spark-gap telegraphy (1888, H. Hertz) to the first clear transmission of human speech in air (1919) and to the invention of frequency modulation (FM) until the early form of mobile phone cellular networks (1947, Bell Labs), wireless technologies and applications have been greatly changed. However, interference is still a Pandora's box in the design and analysis of today's multi-user wireless systems.

In wireless communications, multiple access transmission turns out to be a very common scenario, because (unlike the wire-line communications) radio spectrum is a shared common resource in the sense that every user has the possibility to transmit over it. Interference appears to be a problem (it can even block the transmission process) when several transmitters simultaneously access the same physical link. In this case, receivers obtain a mixed version of all the transmitted signals, and in general it is difficult and expensive to let the receiver distinguish and capture its desired information.

The control and reduction of multiuser interference is a fundamental problem in wireless communications. Many media access technologies together with efficient resource allocation algorithms have been introduced under this setting. All these technologies can be briefly summarized from the viewpoints of *degrees of freedom*:

- **Frequency**

Frequency Division Multiple Access (FDMA) is a channel access method which gives each user an individual allocation of one or several frequency sub-bands (or sub-channels).

FM broadcasting can be considered as a simple example of FDMA.

- **Time**

Time Division Multiple Access (TDMA) is a channel access method which allows several users to share the same frequency channel by dividing the signal into different time slots.

TDMA technology is widely used in the digital 2G cellular systems, e.g., IS-54 (1990) and GSM (1991).

- **Code**

Code Division Multiple Access (CDMA) is a channel access method employing spread-spectrum technology and a special coding scheme (where each transmitter is assigned a code) to allow multiple users to be multiplexed over the same physical link.

CDMA technology leads GSM in migration to 3G, e.g., IS-95B (1999) as 2.5G technology and CDMA2000 (2000) as 3G technology.

- **Space**

Space Division Multiple Access (SDMA) is a multiple input and multiple output (MIMO) based wireless communication technology. In traditional mobile cellular network systems, in order to provide radio coverage, the base station radiates the signal in all directions, since it has no information on the position of the mobile devices within the cell. SDMA is an advanced channel access method which enables access to a communication channel by identifying the user location and establishing a one-to-one mapping between the network frequency division and the identified spatial location.

SDMA technology is considered as a key feature in 4G cellular systems.

With the increasing demand of wireless voice and data services, frequency spectrum has become a scarce resource for which everyone fights for. In fact, the spectral efficiency (efficiency measurement of using frequency spectrum) can be improved by radio resource management techniques such as efficient fixed or dynamic channel allocation, power control, link adaptation and diversity schemes.

Over the past two decades, resource allocation based on information theory [1] and optimization theory [2, 3] has played a central role. For example, waterfilling algorithm [1] is one of the most famous pioneering works that consider how to maximize the channel capacity. However, in order to achieve the information-theoretic limits (e.g., capacity region), it usually requires a central computing resource (a

scheduler with comprehensive knowledge of the network information) to globally schedule and allocate the system resources. This process is centralized, it involves feedback and overhead communication whose load scales linearly with the number of transmitters and receivers in the network.

As the number of cells in the network increases, interference becomes the bottleneck. In the current cellular wireless arena, engineers frequently stumble on the scalability problem. As networks become more and more dense, classical methods based on interference avoidance/cancellation and techniques based on frequency and space reuse or power control are not able to cope with interference due to the increasing number of mobile terminals. The optimization based centralized network infrastructure begins to expose its weakness in many aspects, e.g., slow reconfiguration against varying environment, difficulty in centralizing network information, high cost of network operating expenses, increased computational complexity, etc.

It turns out that due to the different nature of the mobile devices as well as the high mobility of the network, future wireless networks are going towards more self-organizing resource allocations schemes in which mobile devices intelligently allocate resource in a decentralized manner [4]. In recent years, there has been great research interest in self-organizing wireless networks. Tools of game theory [5], as borrowed from economics<sup>1</sup>, has emerged as an adequate framework for the analysis of wireless network resource allocation by modeling devices as selfish players.

## 2. TOOLS OF GAME THEORY

Game theory is a branch of applied mathematics that is used in the social sciences, primarily in economics (in order to model competition between companies), as well as computer science, biology, politics and many other areas. Game theory is a description of strategic interaction, which attempts to mathematically capture behavior in strategic situations, in which an individual's success in making choices depends on the choices of others. It enhances the understanding of conflict by devising theories, mathematical models and abstractions that serve to explain the nature and results of conflict.

### 2.1 Background

In game theory, there are some basic assumptions which are often utilized to facilitate the construction of tractable models for real situations. First, it is assumed that each individual (*player*) in the game has a definite ordering of preferences over all outcomes of a given situation. These preferences take the form of a *utility* function (or *payoff*). Second, the participants in games are sometimes considered to be *rational*. This means they always act in a way that maximizes their payoffs, they will always be capable of thinking through all possible outcomes and choosing that course of action which will result in the best possible outcome.

Thus, one way in which we can informally formulate a game is as a situation where there exist  $K$  decision-making entities or players (whose choices or actions) influence the

<sup>1</sup>In the famous literature *The Wealth of Nations*, Adam Smith (A Scottish moral philosopher, pioneer of political economy, father of modern economics) expounded how rational self-interest and competition can lead to economic prosperity and well-being through macroeconomic adjustments.

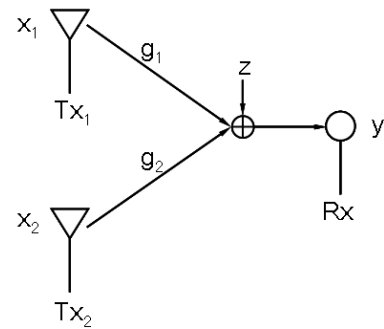

Figure 1: Two-user MAC

outcomes of that situation. A player “attaches” a utility to each one of these outcomes and is motivated to act in a manner that maximizes his utility, given the choices of his opponents. This characterization of an  $K$ -player game is known as the strategic form of a game. Strategic-form game is an appropriate model to interpret the interaction between decision-makers. The model captures interaction between the players by allowing each player to be affected by the actions of all players (not only the player's own action). This paper will mainly focus on the applications of strategic-form games in wireless resource allocation problems.

### 2.2 A motivational example

What is a game problem? What can game theory tools bring to us? To better understand the concepts and principles behind game theory, we provide a simple example in the context of wireless communications, as follows:

Imagine a two-user multiple access channel (MAC), Fig. 1, in which two mobile devices (transmitters)  $x_1$  and  $x_2$  compete to transmit their signals towards a single base station (receiver) in a common wireless channel. There are two choices for both users: either to transmit with low power (denote by “Low”) or transmit with high power (denote by “High”). They must decide simultaneously (without communication) which power level to choose. Typically, this problem can be modelled as a static game with three elements:

- A player set  $\mathcal{K} = \{x_1, x_2\}$ .
- An action set  $A_k = \{\text{Low}, \text{High}\}$ ,  $k \in \mathcal{K}$ , which is the same for both users.
- A payoff function set, which is described by the following matrix<sup>2</sup>:

	Low	High
Low	(win, win)	(lose much, win much)
High	(win much, lose much)	(lose, lose)

where, in each entry  $(a, b)$ , the values  $a$  and  $b$  represent the payoff of player  $x_1$  and  $x_2$ , respectively.

Intuitively, from this payoff matrix, we have the following observations:

<sup>2</sup>Note that here we do not give specific values for the payoffs, but show it in a “win-lose” terminology.

- If both mobiles choose to transmit with high power, they will suffer from the increased interference caused by the other one, which results in a “lose-lose” situation.
- If mobile  $x_1$  chooses to transmit with low power and mobile  $x_2$  chooses to transmit with high power, compared to the “lose-lose” case, mobile  $x_1$  will get a worse performance (denote by “lose much”) and mobile  $x_2$  will benefit from the reduced interference and enjoy a better performance (denote by “win much”).
- If both mobiles choose to transmit with low power, it will result in a “win-win” situation.

Obviously, to find the solution of this problem is beyond the capability of optimization theory, since user  $x_1$ 's best strategy depends on the strategy chosen by user  $x_2$ , which user  $x_1$  does not know, and reciprocally for user  $x_2$ .

Readers may guess that both mobiles must strictly prefer to transmit with low power. However, this “win-win” situation is not the solution of this game, i.e., it is not a natural outcome of rational players. It might be quite surprising that the only solution, the pure Nash equilibrium<sup>3</sup>, of this game is the “lose-lose” situation.

### 2.3 Methodology to study game problems

In such a non-cooperative strategic-form game, what actions should the players choose? The famous Nash equilibrium represents a common solution concept that is mutual optimal, in the sense that no player has any motivation to deviate from it. In general, to analyze Nash equilibrium, there are three main questions that should be considered, which are “existence”, “uniqueness” and “selection”. Here, we briefly discuss this methodology in general situations [6, 7],

1. Existence - Does an equilibrium exist?
2. Uniqueness - Does there exist a unique equilibrium or multiple ones?
3. Selection - How to select a favouring equilibrium from the equilibrium set?

“Existence” is the very first question that naturally comes into our mind, since it is known that, in general, an equilibrium point does not necessarily exist. Mathematically speaking, proving the existence of an equilibrium is equivalent to proving the existence of a solution to a fixed-point problem [8]. Since the existence of the fixed-point hints that there is some strategy set which is a best response to itself, therefore no player could do any better by deviating, and so it is an equilibrium. Fortunately, there are many scenarios based on usual channel models and performance metrics (e.g. Shannon transmission rate and rate regions have desirable convexity properties [9] that are in favor of the existence of an equilibrium [10]) where existing theorems are sufficient.

“Uniqueness” is the second fundamental problem that we need to address when the existence is ensured. Ideally, we would prefer there to be a unique equilibrium because it is the simplest solution form for general game-theoretical

<sup>3</sup>A Nash equilibrium, named after John Nash, is a set of strategies, one for each player, such that no player has incentive to unilaterally change her action.

problems, and it is important not only for predicting the state of the network but also crucial for convergence issues. Unfortunately, there are not so many general results on the topic of equilibrium uniqueness. One could find some useful results in the *concave N-person games* [10], where it is shown that there exists exactly a unique equilibrium if the payoff functions satisfy the condition of *diagonally strictly concave* which can be easily verified.

However, there are many important scenarios where the equilibrium is not unique, e.g., routing games [11], coordination games [12], non-cooperative games with correlated constraints together with the concept of “generalized Nash equilibrium” [13], etc. Natural questions that arise concern the selection of an appropriate equilibrium, i.e.,

- What can be done when one has to deal with a game having multiple equilibria?
- Are there some equilibria “dominating” others?
- Are there some equilibria more “fair” than others?
- What is a “good” selection rule to follow?

As a matter of fact, “equilibrium selection” is a mature theory in itself [14]. But here, instead of paying attention to the general theory, we are more interested in the applications of concave games, where Rosen has already introduced the notion of “normalized equilibria” [10] that shows a very neat way to tackle this selection problem. Obviously, the selection rule is strongly related to the fairness criteria uses, e.g., max-min fairness [15], proportional fairness [16, 17], Jain’s fairness [18], global optimization and normalized equilibrium, etc. Specifically, the authors of [7] have shown that the max-min fairness, proportional fairness and normalized equilibrium achieve the same rate allocation in the context of multiple access channels with multi-user detection. Up to now, equilibrium selection is still an open topic in many communication network models and applications, especially for the case of non-convex rate region, e.g., achievable rate region of collision channels and interference channels.

## 3. GAMES THEORY IN WIRELESS COMMUNICATIONS

In recent years, there has been some great interest in self-organizing wireless networks in which mobile devices allocate resource in an intelligent way. There are three main ingredients that make game theory to be a fruitful theory for future wireless analysis and design:

1. Future generation wireless networks will most likely consist of intelligent radio devices, capable to sense the environment and effectively adjust their transmission parameters according to the current local channel conditions and QoS specifications.
2. Wireless channel is considered as a shared common resource (frequency, time, power, space, etc.) which implies competition and cooperation between wireless devices. In some sense, wireless resource allocation will not be simply considered as an optimal way to “share a cake”, but a complex resource conflict between intelligent decision makers.
3. Wireless networks are highly structured which favors the success of game theoretic analysis.

The decision makers in the game are rational users or network operators who control their communication devices. Indeed, game theory is an appropriate mathematical tool to model the interaction and to solve the resource conflicts existing in the wireless networks. Here, we illustrate several basic game theory tools that have already been used in the literature.

### 3.1 Wireless game with complete information

We call it a game with complete information, if the game structure (which includes play set, action set and payoff functions) is available to all players. For example, “chess” is a game with complete information, because the chess players, chess moves and each player’s objective are known to all players.

Many efforts have been made in this direction, since it is considered as an initial step. Game theory has been widely applied to study the resource allocation and power control problems in various types of networks, such as fading MAC [19], orthogonal frequency division multiplexing (OFDM) [20], multiple input and multiple output (MIMO) channels [21, 6, 22], and interference channels [23], etc.

The weakness of this game-theoretic approach is that the game models used in these previous works assume that the information/knowledge about other devices is available to all devices. However, this assumption is hardly met in practice. In practical wireless communication systems, devices can have local information but can barely access to global information on the network status.

### 3.2 Wireless game with incomplete information

In game theory, a strategic game with incomplete information is called a “Bayesian game”. In contrast to games where devices have complete information about other devices, it is of great interest to investigate scenarios where devices have “incomplete information” about their components. The notion of “incomplete information” means that some players do not completely know the structure of the game. For example, “poker” is a game with incomplete information, because players are uncertain about the card states of other players, therefore, the exact object functions of other players are unknown.

Before talking about games with incomplete information, we need to clarify two other similar notions: “imperfect information” and “imperfect (or partial) channel state information (CSI)”. The former “Imperfect information” is a common notion used in the sequential games [5], in contrast to games of perfect information, a game is said to have imperfect information if not all players know all moves that have taken place (or the history of the game is not available to all players). The latter “imperfect/partial CSI” is a specific term widely used in the wireless communication society, it means that the channel information is not perfectly estimated/observed at the transmitter/receiver side.

It is important to note that the assumption of incomplete information is closely related to the two notions mentioned above. For example: we can consider the following communication scenario with imperfect CSI as a game of incomplete information: a device has perfect CSI about its own channel, but it has imperfect CSI about any other device’s channel. Note that this is a common situation that usually happens in a wireless network, since it may be too “expensive” for

every device to keep track of the time-variant channels of all other devices.

Unfortunately, in wireless communications, there are not many references using Bayesian games to model and solve the resource allocation problem. In [24], a static Bayesian game-theoretic model is applied to the problem of transmit power determination in the uplink of a self-organizing CDMA wireless network. In another important work [25], Bayesian game model is applied to study the two-user multi-channel (or multi-carrier) interference channels, where each wireless device selects a power profile over the entire available bandwidth to maximize its data rate. The authors show that there exists a unique Bayesian equilibrium under the assumption of single-user detector (each user treats interference as noise and no interference cancellation techniques are used) and finite (typically selected) action set. In [26], for multiuser fading MAC, under the assumption of discrete (finite) channel states, the authors show that there exists exactly one Bayesian equilibrium in the game. The efficiency of Bayesian equilibrium is studied in their numerical results.

### 3.3 Wireless game via Nash bargaining

Nash bargaining is a natural framework that allows us to define and design a fair assignment of wireless resource, e.g., transmission rate, between players which will play the role of *bargainers*. It is characterized by a set of axioms that are appealing in defining fairness or by a maximization of log-concave function on the set of feasible sum-rates. Nash bargaining solution (NBS) is an interesting solution concept since it can be seen as a natural extension of the proportional fairness criterion which is probably the most popular fairness. In such a game, players are faced with the problem to negotiate for a fair point in the convex set of feasible rates. If no agreement can be achieved by the players, the disagreement utilities (sum-rate) is obtained.

In fact, NBS is applied widely in network resource allocation. For example, in [27], a criterion based on NBS is applied to orthogonal frequency division multiple-access (OFDMA) networks. This method generalizes the proportional fairness and increases the efficiency of the system. In [28], the ideas of max-min fairness, proportional fairness and NBS have been applied to the Gaussian multiple access channel (MAC) and the Gaussian broadcast channel (BC). Algorithms have been designed to locate the fair point in the capacity region. In [29], cooperative game is used to provide preferred points on the boundary of the achievable rate region for a simple  $2 \times 2$  interference channel. From their simulation results, the cooperative solution NBS is shown to significantly outperform the competitive NE. In [30], NBS is studied as a tool to achieve point(s) on the Pareto frontier of the game theoretical rate region under asymmetric conditions for OFDM hot-spot networks. A stochastic algorithm is proposed.

## 4. CONCLUSIONS

In this paper, we have discussed the use of game theory in future wireless network. From a simple motivational example, we showed what is a game problem and we discussed the methodology to analyze the solution of a game problem. We have summarized several game theory tools that can be applied to study the wireless resource allocation problems.

## REFERENCES

- [1] T. M. Cover and J. A. Thomas, *Elements of Information Theory*, Wiley, 1991.
- [2] S. Boyd and L. Vandenberghe, "Convex Optimization," *Cambridge University Press*, 2004.
- [3] M. Chiang, "Geometric Programming for Communication Systems," *Foundations and Trends in Communications and Information Theory*, vol. 2, no. 1/2, pp. 1-153, 2005.
- [4] M. Debbah, "Mobile Flexible Networks: The challenges ahead", *2008 International Conference on Advanced Technologies for Communications*, invited paper, Hanoi, Vietnam.
- [5] D. Fudenberg and J. Tirole, *Game Theory*, MIT Press, 1991.
- [6] S. Lasaulce, M. Debbah and E. Altman, "Methodologies for analyzing equilibria in wireless games", *IEEE Signal Processing Magazine, Special issue on Game Theory for Signal Processing*, pp. 51-68, Sep. 2009.
- [7] E. Altman, L. Cottatellucci, M. Debbah, G. He and A. Suarez, "Operating Point Selection in Multiple Access Rate Regions", *International Teletraffic Congress*, Paris, France, Jun. 2009.
- [8] J. F. Nash, "Equilibrium points in n-persons games", *Proc. of the National Academy of Science*, vol. 36, no. 1, pp. 48-49, Jan. 1950.
- [9] S. Boyd and L. Vandenberghe, *Convex Optimization*, Cambridge University Press, 2004.
- [10] J. B. Rosen, "Existence and Uniqueness of Equilibrium Points for Concave N-Person Games", *Econometrica*, vol. 33, pp. 520-534, July 1965.
- [11] T. Roughgarden and E. Tardos, "Bounding the Inefficiency of Equilibria in Nonatomic Congestion Games", *Games and Economic Behavior*, vol. 47, pp. 389-403, 2004.
- [12] R. Cooper, "Coordination Games", *Cambridge University Press*, 1998.
- [13] E. Altman and A. Shwartz, "Constrained Markov Games: Nash Equilibria", *Annals of Dynamic Games*, Vol. 5, pp. 213-221, 2000.
- [14] J. C. Harsanyi and R. Selten, "A General Theory of Equilibrium Selection in Games", *MIT Press*, Mar. 2003.
- [15] S. Floyd, "Connections with Multiple Congested Gateways in Packet-Switched Networks Part 1: One-way Traffic", *Computer Communication Review*, Oct. 1991.
- [16] F.P. Kelly, "Charging and Rate Control for Elastic Traffic", *Eur. Trans. Telecom.*, vol. 8, pp. 33-37.
- [17] F.P. Kelly, A. Maullo and D. Tan, "Rate Control for Communication Networks: Shadow Prices, Proportional Fairness and Stability", *J. Oper. Res. Soc.* vol. 49, 1998.
- [18] D. Chiu and R. Jain, "Analysis of the Increase and Decrease Algorithms for Congestion Avoidance in Computer Networks", *Comput. Networks ISDM Syst.m*, vol. 17, pp. 1-14, 1989.
- [19] L. Lai and H. El Gamal, "The Water-Filling Game in Fading Multiple-Access Channels", *IEEE Trans. on Information Theory*, Vol. 54, No. 5, pp. 2110-2122, May 2008.
- [20] G. He, S. Beta and M. Debbah, "Game-Theoretic Deployment Design of Small-Cell OFDM Networks", *3rd ICST/ACM International Workshop on Game Theory in Communication Networks*, Oct. 2009.
- [21] D. P. Palomar, J. M. Cioffi, M. A. Lagunas, "Uniform Power Allocation in MIMO Channels: A Game Theoretic Approach", *IEEE Trans. on Information Theory*, Vol. 49, No. 7, pp. 1707-1772, July 2003.
- [22] E. V. Belmega, S. Lasaulce, and M. Debbah, "Power allocation games for MIMO multiple access channels with coordination", *IEEE Trans. on Communications*, 2008.
- [23] E. Altman, M. Debbah and A. Silva, "Game Theoretic approach for routing in dense ad-hoc networks", *Stochastic Networks Workshop*, Edinburg, UK, July, 2007.
- [24] S. Jean and B. Jabbari, "Bayesian game-theoretic modeling of transmit power determination in a self-organizing CDMA wireless network," *Proc. IEEE VTC Fall 2004*, vol. 5, pp. 3496-3500, Sep. 2004.
- [25] S. Adlakha, R. Johari and A. Goldsmith, "Competition in Wireless Systems via Bayesian Interference Games", <http://arxiv.org/abs/0709.0516>, Sep. 2007.
- [26] G. He, M. Debbah and E. Altman, "A Bayesian Game-Theoretic Approach for Distributed Resource Allocation in Fading Multiple Access Channels", submitted to *EURASIP Journal on Wireless Communications and Networking, Special issue on Femtocell Networks*, 2009.
- [27] Z. Han, Z. Ji and K. J. R. Liu, "Fair Multiuser Channel Allocation for OFDMA Networks Using Nash Bargaining Solutions and Coalitions", *IEEE Transactions on Communications*, vol. 53, no. 8, Aug. 2005.
- [28] K. W. Shum and C. W. Sung, "On the Fairness of Rate Allocation in Gaussian Multiple Access Channel and Broadcast Channel", <http://arxiv.org/abs/cs/0611015v1>, submitted on Nov. 2006.
- [29] A. Leshem and E. Zehavi, "Cooperative game theory and the Gaussian interference channel", *IEEE Journal on Selected Areas in Communications*, Vol. 26, pp. 1078-1088, Sep. 2008.
- [30] G. He, H. Tembine and M. Debbah, "Deployment Analysis of cooperative OFDM base stations", *IEEE International Conference on Game Theory for Networks*, Istanbul, Turkey, 2009.