

Original Article

Towards a footwear design tool: influence of shoe midsole properties and ground stiffness on the impact force during running.

Quoc Hung LY^{1,2}, Amina ALAOU^{2(*)}, Silvano ERLICHER², Laurent BALY¹

¹ *OXYLANE RESEARCH, 4, Boulevard de Mons, F-59650, VILLENEUVE D'ASCQ, France*

² *Université Paris-Est, UR Navier, Ecole des Ponts ParisTech, 6 et 8 av. B. Pascal, Cité Descartes, Champs-sur-Marne, 77455 Marne-la-Vallée, cedex 02, France*

(*) Corresponding author.

Tel: ++33 (0) 164 153730
Fax: ++33 (0) 164 153741
E-mail: alaoui@lami.enpc.fr

Keywords: Running impact force, Dynamic model, Mid-soles dynamic properties, Ground stiffness, footwear design.

Word count: 3020

Abstract

Several spring-damper-mass models of the human body have been developed in order to reproduce the measured ground vertical reaction forces during human running (McMahon and Cheng, 1990; Ferris and Farley, 1999; Liu and Nigg, 2000). In particular, Liu and Nigg introduced at the lower level of their model, i.e. at the interface between the human body and the ground, a nonlinear element representing simultaneously the shoe mid-soles and the ground flexibility. The ground reaction force is modelled as the force supported by this nonlinear element, whose parameters are identified from several sets of experimental data. This approach proved to be robust and quite accurate. However, it does not explicitly take into account the shoe and the ground properties. It turns out to be impossible to study the influence of shoe materials on the impact force, for instance for footwear design purposes. In this paper, a modification of the Liu and Nigg's model is suggested, where the original nonlinear element is replaced with a bi-layered spring-damper-mass model: the first layer represents the shoe mid-sole and the second layer is associated with the ground.

Ground is modeled as an infinite elastic half-space. We have assumed a visco-elastic behaviour of the shoe material, so the damping of shoe material is taken into account. A methodology for the shoe soles characterization is proposed and used together with the proposed model. A parametric study is then conducted and the influence of the shoe properties on the impact force is quantified. Moreover, it is shown that impact forces are strongly affected by the ground stiffness, which should therefore be considered as an essential parameter in the footwear design.

1. Introduction

During running activity, the human body is exposed to repetitive impact forces, which may cause the development of lower back pain and running injuries for runners (Clement et al., 1981; James et al., 1978). This is one of the reasons why the modelling and the reduction of impact forces are important axes of investigation in the field of biomechanical research. Other reasons are the need of improving muscle tuning and comfort during running. One can also observe that athletes adjust their kinematics and kinetics quickly when changing from one impact condition to another one.

The first studies on this subject dealt with the understanding of the intrinsic attenuation mechanisms in the human body. Indeed, two different categories can be distinguished in the technical literature: (i) the active shock absorption including joint positioning (Bobert et al., 1992; Denoth., 1986) and muscle activity (Christina et al., 2001) and (ii) the passive shock absorption including synovial fluid, bone, heel pad and articular cartilage. A different mechanism has also been identified, involving the knee flexion amplitude during running: it has been proven that it also plays a dominant role in the shock absorption (Bobert et al., 1992; Denoth., 1986; Lafortune et al., 1996).

The effectiveness of these shock absorption mechanisms is bounded by biomechanical or morphological constraints, and it is very difficult to modify them in order to increase cushioning during running. Hence, a further increase of the global attenuation should be obtained by rather acting on the shoe properties (midsoles mainly) and properly accounting for ground stiffness.

Concerning the midsole influence, some experimental studies concluded that there is a strong correlation between the attenuation of impact force peaks and the decrease of shoe sole stiffness (Lafortune et al., 1996; Aerts and De Clercq, 1993). Other authors showed that shoe sole stiffness has no or small influence on the impact force peaks (Clarke et al., 1983; Nigg, 1983; Snel et al., 1985; DeVita and Bates, 1987). The different experimental protocols (fixed leg or heel or fixed foot-shoe combination) can partially explain these discrepancies. However, the main reason of this lack of consensus may result from the way the notion of shoe sole stiffness is defined in each analysis. Repetitive impacts during running are a dynamic phenomenon. Hence, a pertinent description of the running impact forces cannot be exclusively based on the knowledge of shoe-sole stiffness, but the damping should be also accounted for. Let us quote, for example, the work of Cole (1995) who

described the impact force as a nonlinear function of the impact rate taking into account the material properties of heel pad, shoe and contact surface. The same definition was also used by Nigg (1999, 2000) to model the impact loading during running.

In the literature, the impact forces are studied by both experimental investigations and developing mechanical models of the body-shoe-ground system. Simple spring-damper-mass models have been successfully developed by (Alexander, 1988; Cavagna et al., 1988; Farley and Gonzalez, 1996; Ferris and Farley, 1997; Ito et al., 1983; McMahon and Cheng, 1990; Kim et al., 1994; Nigg and Anton, 1994). However, all these models neglected non rigid masses of the body, like muscles and other soft tissues. Indeed, human body is constituted by both rigid parts (bones) and soft tissues linked each other through elastic and viscous connections.

Liu and Nigg (2000) and Nigg and Liu (1999) proposed a model of the human body for describing running taking into account both rigid and wobbling masses. These authors used their model to study the influence of masses, mass ratios, stiffness constants and damping coefficients on the simulated impact force. A few years later, Zadpoor and co-workers (Zadpoor and Nikooyan, 2006; Zadpoor et al., 2007) brought some corrections to the parameters (impact velocities, coefficients of the function of the ground reaction force) used by Liu and Nigg.

The objective of our study is to develop a tool for the design of shoe soles for running. The work is focused on modelling the impact of the heel on the ground and takes into account the different mechanical and biomechanical parameters involved during this impact

For the biomechanics of the human body, we started from the work of Liu & Nigg and the modifications suggested by Zadpoor & Nikooyan (LNZN model). However, in this model, characterization of the shoe soles is obtained using the human pendulum test and thus doesn't correspond to an intrinsic property (neither material nor structural) of soles. Furthermore the LNZN model does not take explicitly into account the stiffness of soil.

To create this design tool, we have coupled the LNZN model with a bi-layered subsystem representing the mass, stiffness and damping of the shoe sole and the ground stiffness allowing us to integrate visco-elastic properties of soles and estimates of soil stiffness. The mechanical testing protocol of soles properties is precisely described and the ground stiffness is evaluated by a FE calculation.

We then set the dynamic equations of this new model that we have programmed into the Matlab code to study the influence of the various parameters involved.

2. Methods

In this section, two models are presented: (i) the Liu and Nigg (2000) model with the modifications suggested by Zadpoor and Nikooyan (2007) (LNZN model) and (ii) the new model proposed in this paper. The main novelty introduced here consists in adding to the LNZN model a bi-layered spring-damper-mass subsystem, associated with midsoles and ground. As it will be seen hereafter, this modification allows a clear interpretation of the role of the ground and of shoe sole properties on the running impact force.

2.1 LNZN model

The original model of Liu and Nigg is represented by the scheme of Figure 1a. The rigid and wobbling masses of the system are described in the caption of the Figure, and the parameters are listed in Table 1. The corresponding equations of motion read:

$$\begin{aligned}
 m_1 \ddot{x}_1 &= m_1 g - F_g - k_1(x_1 - x_3) - k_2(x_1 - x_2) - c_1(\dot{x}_1 - \dot{x}_3) - c_2(\dot{x}_1 - \dot{x}_2), \\
 m_2 \ddot{x}_2 &= m_2 g + k_2(x_1 - x_2) - k_3(x_2 - x_3) + c_2(\dot{x}_1 - \dot{x}_2), \\
 m_3 \ddot{x}_3 &= m_3 g + k_1(x_1 - x_3) + k_3(x_2 - x_3) - (k_4 + k_5)(x_3 - x_4) + c_1(\dot{x}_1 - \dot{x}_3) - c_4(\dot{x}_3 - \dot{x}_4), \\
 m_4 \ddot{x}_4 &= m_4 g + (k_4 + k_5)(x_3 - x_4) + c_4(\dot{x}_3 - \dot{x}_4),
 \end{aligned} \tag{1}$$

where g is the gravity acceleration. The vertical contact force F_g is defined as follows:

$$\begin{aligned}
 F_g &= A_c \left(a x_1^b + c x_1^d \dot{x}_1^e \right) \quad (x_1 > 0) \\
 F_g &= 0 \quad (x_1 \leq 0)
 \end{aligned} \tag{2}$$

It is a nonlinear viscoelastic force, which represents simultaneously the material properties of the heel pad, shoe and contact surface. The parameters a , b , c , d and e were assumed to be shoe-specific, since the heel pad and the ground were unchanged during the tests. Two types of shoe-foot models (soft and hard) were used in the simulations, with parameter values determined by pendulum impact tests (cf. Table 2). The constant A_c was taken to be 2, assuming that the average contact area during ground contact was twice the contact area between

the impact pendulum and the foot in the experiments of Aerts and De Clercq (1993). The same vertical velocities (0.6m/s) at touchdown were chosen for all body masses.

Zadpoor and Nikooyan (2007) showed that some parameters of Liu and Nigg's model had to be modified in order to give a better fitting of the experimental results of the impact force. These authors proposed the parameter values and the touchdown velocities listed in Table 3. In summary, The LNZN model is defined by Eqs. (1)-(2) and Table 3.

2.2 The new model

Starting from the LNZN model, a new mechanical model is proposed here, characterized by bi-layered subsystem representing the mass, stiffness and damping of the shoe and the ground stiffness (Figure 1b). As a result, it is possible to distinguish the ground reaction force F_g from the contact force between the foot and the shoe sole, indicated by F_s .

The theoretical aspects of the new model were first published in Ly et al. (2008). In this first version, we considered *linear* viscoelastic behaviour for shoe soles. The model proposed in this study includes a new method of characterization and identification of the viscoelastic behaviour of shoe soles taking into account geometric nonlinearities. Furthermore, this new model presents also a method of estimation of ground stiffness from the literature data.

Estimation of ground stiffness:

Ground is modeled as an infinite elastic half-space. A unit load F is applied over a circular area of 40 mm radius, corresponding to the average size of the contact area of sole/ground, in the form of uniform pressure.

The ground stiffness is then calculated as: $k_s = \frac{F}{u_{\max}} = \frac{1}{u_{\max}}$ where u_{\max} represents the maximum displacement of the soil under load. Calculations were made using ABAQUS FE software.

Using literature data on elastic modulus for soils, we computed estimations of the ground stiffness using two approaches. For the study, we then considered six different soils whose properties are summarized in Table 4. Details are given in Appendix A.

Viscoelastic properties of shoe soles and model dynamics equations:

The shoe sole is modelled as a unique structure submitted to the impact of the heel during running. The load is thus considered, according to ASTM F 1976, as an impact load applied through a spherical indenter on the rear part of the sole (Figure 2). We have assumed a visco-elastic behaviour of the shoe material, where the geometric nonlinearity, due to contact between the slightly convex shape of the rear of the sole and the spherical shape of the impactor, is taken into account for calculating the soles elastic stiffness k_6 following a Hertz type contact law:

$$F = k_6 * u * \left(\frac{u}{R_0} \right)^{b_6-1} \quad \text{where } R_0 \text{ is the radius of the indenter}$$

According to the scheme of Figure 1b, the expression of the ground reaction force reads

$$F_g = -k_s x_5 \quad (3)$$

whereas the force between the foot and the shoe sole becomes:

$$F_s = -k_6 * \left(x_1 - x_5 \right) * \left(\frac{(x_1 - x_5)}{R_0} \right)^{b_6-1} - c_6 \left(\dot{x}_1 - \dot{x}_5 \right) \quad (4)$$

This approach makes it possible to insert into the model the shoe sole properties (m_5, k_6, b_6, c_6), as well as the ground stiffness (k_s). Hence, the influence of these quantities on the impact force F_s exerted on the foot can be easily evaluated (see equation 4). The equations of motion for the new system read:

$$\begin{aligned} m_1 \ddot{x}_1 &= m_1 g + k_1 (x_3 - x_1) + k_2 (x_2 - x_1) - k_6 \left((x_1 - x_5) * \left(\frac{(x_1 - x_5)}{R_0} \right)^{b_6-1} \right) + c_1 (\dot{x}_3 - \dot{x}_1) + c_2 (\dot{x}_2 - \dot{x}_1) + c_6 (\dot{x}_5 - \dot{x}_1) \\ m_2 \ddot{x}_2 &= m_2 g + k_2 (x_1 - x_2) + k_3 (x_3 - x_2) + c_2 (\dot{x}_1 - \dot{x}_2) \\ m_3 \ddot{x}_3 &= m_3 g + k_1 (x_1 - x_3) + k_3 (x_2 - x_3) + (k_4 + k_5) (x_4 - x_3) + c_1 (\dot{x}_1 - \dot{x}_3) + c_4 (\dot{x}_4 - \dot{x}_3) \\ m_4 \ddot{x}_4 &= m_4 g + (k_4 + k_5) (x_3 - x_4) + c_4 (\dot{x}_3 - \dot{x}_4) \\ m_5 \ddot{x}_5 &= m_5 g + k_6 \left((x_1 - x_5) * \left(\frac{(x_1 - x_5)}{R_0} \right)^{b_6-1} \right) - k_s x_5 + c_6 (\dot{x}_1 - \dot{x}_5) \end{aligned} \quad (5)$$

A MATLAB code has been developed to solve this equation system. Let us remind that these simulations do not include take off-phase running. Therefore, the vertical movement is simulated only for the first 250 ms after touchdown. The parameters and initial conditions are the same as those of the LNZN model for all masses representing the human body (Table 3). Concerning the shoe (m_s), the assumption that the foot is perfectly stuck on the shoe at the initial time is done. Hence, the shoe touchdown velocity is taken equal to that of the lower rigid body mass (m_l).

2.3 Determination of viscoelastic properties of shoe soles

The horizontal speed of the race determines the frequency of impacts, which then determines the frequency of the mechanical testing protocol for the characterization of viscoelastic shoe insoles. In this study, the viscoelastic characteristics are obtained for a frequency of 1.5 Hz.

As for the simplified model of the human body (LNZN model), the shoe sole is modelled by a mass (m_s) - spring (k_6) - damper (c_6) system. The exponent (b_6) is arising from the geometric nonlinearity, due to contact between the shoe sole and the indenter.

For this study, we have tested 4 running shoes. They all have the same shape and they differ only by the hardness of the midsoles material: 40 Asker C, 50 Asker C, 60 Asker C and 65 Asker C. The tests were carried out using a ZWICK ROELL HC25 hydraulic machine, and the load applied via a cylindrical indenter with a spherical tip (Figure 2). An oscillating sinusoidal force is applied on the rear area of the sole, corresponding to the supporting surface of the heel at initial impact. From the stabilized cycle, we determine the parameters $k_6(f)$ and $b_6(f)$ relating to the elastic behaviour of the sole, by interpolating the whole cycle as a power law. The value of energy dissipation during a loading cycle is then used to calculate the value of $c_6(f)$. An example of the testing results and the evaluation of the shoe sole mechanical parameters is shown on Figure 3.

3. Results

3.1 Mechanical properties of shoe soles

The results presented hereafter are related to the 4 selected shoes and correspond to a load amplitude of 1200N ($F_{\max} = 1400\text{N}$, $F_{\min} = 200\text{N}$) and a frequency of 1.5 Hz. The values of the parameters $k_6(f)$, $b_6(f)$ and $c_6(f)$ are computed as described in the previous section. The results are gathered in Table 5.

3.2 Reaction forces

Having now the values for the new parameters of our model, we can compute, as for the original model, the ground reaction force F_g and the velocities but also the impact force F_s exerted on the foot and thus the difference $F_g - F_s$ corresponding to specific influence of the shoe. Results of simulated ground reaction forces are presented on Figures 4 and 5, corresponding to two different soil stiffness values. On Figures 6 and 7, we have plotted the difference $F_g - F_s$, that can be seen as the intrinsic cushioning of the shoe sole, for the same soils.

3.3 Loading rate and passive force peak level

The evolution of the ground reaction force allows us to determine the passive peak (first force peak level) and to calculate the loading rate (between 10% and 90% of the passive peak). As we can notice on Figures 8a and 8b, the evolution of the passive peak versus the ground stiffness presents a minimum while the loading rate increases in an almost linear way. These evolutions are summarized on Figures 9a and 9b for all studied shoes.

4. Discussion

The main purpose of this paper is a proper modelling of the impact force during running. However, the model also provides other information, like the acceleration of the lower mass. Moreover, the presence of a layer associated with the shoe-sole, allows the deformation of the shoe-sole material to be computed.

4.1. Influence of the ground stiffness k_s

The usual models for evaluating the impact force do not explicitly account for the ground stiffness effect. However, the simple spring element introduced here (stiffness k_s) shows the great importance of the ground on the impact force. From Figures 9a and 9b, one can see that the passive force peak and the loading rate, as well as the time evolution of the reaction force, are deeply affected by the ground stiffness. In particular, for all shoes, low value of ground stiffness can cancel out the first impact force peak. This result is important for shoe design, in order to better adapt shoe cushioning according to the running surface. Another conclusion, highlighted through Figures 6, 7 and 9c, is that the shoe cushioning is not really meaningful for soft soils, as the intrinsic gain ($(F_g - F_s)_{\max}$) is less than 2%, while it represents almost 10% for hard surface. Runners adjust leg stiffness for their first step on a new surface (Ferris et al., 1999). However, supposing that the leg stiffness does not change during

running, it has been shown in this paper that the variations of the impact forces due to the modifications of the ground stiffness are significant and that the ground stiffness should be considered as an essential parameter in shoe cushioning design criteria.

4.2. Influence of shoe sole

As we can notice on Figures 4 and 5, shoe characteristics have very small influence on loading rate but contribute significantly to the first force peak level, mainly for stiff soils (fig. 7.). Besides, for a ground of stiffness higher than 350 kN/m, we observe a good correlation between the attenuation of impact force peaks and the decrease of shoe sole stiffness (fig. 9). This result confirms works led by Lafortune et al. (1996) or Aerts and Clercq (1993). While for ground stiffness lower than 350 kN/m, it seems that shoe sole stiffness has almost no influence on the impact force peaks. We find here the conclusions of Clarke et al. (1983), Nigg (1983) or Snel et al. (1985). The ground stiffness could thus be one reason in this lack of consensus concerning the correlation between shoe sole stiffness and the attenuation of impact force peaks.

4.3. Acceleration of lower rigid mass (m_l)

Tibial acceleration is often used as criterion for evaluating the shoe-sole cushioning. Typical values of tibial accelerations are given in Table 6 (Lafortune, 1991). Measured acceleration magnitudes are affected by many factors such as location and fixation of sensors, running velocity, running level and also by wearing conditions. Hence, experimental results in literature cannot be easily compared. Moreover, the “physical” location of the mass m_l of the model corresponds only approximately to tibia.

Figure 10 illustrates and compares the time evolution of the acceleration (mass m_l), with $k_s = 880$ kN/m and a load frequency of 1.5 Hz. Table 6 shows the minimum and maximum mass m_l acceleration predicted by the model as a function of the ground stiffness, for a stride frequency of 1.5Hz.

It is difficult to compare quantitatively these values of acceleration with those of the literature, because we have no information about the subjects involved in the tests of the authors quoted on Table 7. Also, the ground stiffness is not estimated and shoes cannot be compared because they were not characterized in the same way. However, the values of acceleration are of the same order than those in the literature.

5. Conclusions

A mechanical model has been developed, able to predict the time evolution of the vertical impact running force. It provides results consistent with those reported in the literature. In addition, it suggests a new approach in the modelling of the mechanical interaction between the human body and the ground through the shoes: the reaction force is no longer represented by a nonlinear function depending on coefficients without a clear physical meaning, but is defined explicitly accounting for the ground and shoe-soles material properties.

A first result obtained by this model concerns the quantitative evaluation of the ground stiffness influence on the impact running forces. Moreover, it has been proposed an approach for the characterization of the shoe-soles mechanical properties accounting for the influence of geometrical non-linearity due to the contact. This methodology has been applied to a sample of 4 shoes, but it can be used for every type of shoe material and thickness. Hence, it constitutes a very effective footwear design tool, which can be used independently or together with the proposed model.

References

- Aerts, P., De Clercq, D., 1993. Deformation characteristics of the heel region of the shod foot during a simulated heel strike: the effect of varying midsoles hardness. *Journal of Sports Science* 11, 449-461.
- Alexander, R.M., 1988. *Mechanism in animal movement*. Cambridge University Press, Cambridge.
- Bobert, M.F., Schamhardt, H.C., Nigg, B.M., 1991. Calculation of ground reaction force estimates during running from positional data. *Journal of Biomechanics* 24, 1095-1105.
- Bobert, M.F., Yeadon, M.R., Nigg, B.M., 1992. Mechanical analysis of the landing phase in heel toe running. *Journal of Biomechanics* 25, 225-234.
- Cavagna, G.A., Franzetti, P., Heglund, N.C., Willems, P., 1988. The determinants of step frequency in running, trotting, and hopping in man and other vertebrates. *Journal of Physiology London* 399, 81-92.
- Cavanagh, P.R., Lafortune, M.A., 1980. Ground reaction forces in distance running. *Journal of Biomechanics* 13, 397-406.
- Clarke, T.E., Frederick, E.C., Cooper, L.B., 1983. The effects of shoe cushioning upon ground reaction forces in running. *International Journal of Sports Medicine* 4, 257-241.
- Clement, D.B., Tauton, J.E., Smart, G.W., McNicol, K.L., 1981. A survey of overuse running injuries. *Medicine and Science in Sports and Exercise* 13, 83.
- Cole, G.K., 1995. Loading of the joints of the extremities during the impact phase in running. Ph.D. Thesis. Department of Mechanical Engineering, The University of Calgary, Calgary, 1995.
- Christina, K.A., White, S.C., Gilchrist, L.A., 2001. Effect of localized muscle fatigue on vertical ground reaction forces and ankle joint motion during running. *Human Movement Science* 20, 257-276.
- Denoth, J., 1986. Load on the locomotor system and modelling. In: Nigg, B.M. (Ed.), *Biomechanics of running shoes*. Human Kinetics Publishers, Champaign, pp. 63-116.
- DeVita, P., Bates, B.T., 1987. In: Jonsson, B. (Ed.). *The effects of Time on Selected Ground Reaction Force Parameters*. Human Kinetics Publisher, Champaign, IL, 909-912.
- Farley, C.T., Gonzalez, O., 1996. Leg stiffness and strike frequency in human running. *Journal of Biomechanics* 29, 181-186.
- Ferris, D.P., Farley, C.T., 1997. Interaction of leg stiffness and surface stiffness during human hopping. *Journal of Applied Physiology* 82, 15-22.
- Ferris, D.P., Liang, K., Farley, C.T., 1999. Runners adjust leg stiffness for their first step on a new running surface. *Journal of Biomechanics* 32, 787-794.
- Henning, E.M., Lafortune, M.A., 1989. Tibial bone acceleration and ground reaction force parameters during running. *Journal of Biomechanics* 22, 1043.
- James, S.J., Bates, B.T., Osterning, L.R., 1978. Injuries to runners. *American Journal of Sports Medicine* 6, 40-50.
- Lafortune, A.M., 1991. Three-dimensional acceleration of the tibia during walking and running. *Journal of Biomechanics* 24, 877-886.
- Lafortune, A.M., Lake, M.J., Henning, E.M., 1995. Transfer function between tibial acceleration and ground reaction force. *Journal of Biomechanics* 28, 113-117.

- Lafortune, A.M., Henning, E.M., Lake, M.J., 1996. Dominant role of interface over knee angle for cushioning impact loading and regulating initial leg stiffness. *Journal of Biomechanics* 29, 1523-1529.
- Liu, W., Nigg, B.M., 2000. A mechanical model to determine the influence of masses and mass distribution on the impact force during running. *Journal of Biomechanics* 33, 219-224.
- Ly, Q. H., Alaoui A., and Baly L., 2008 'Influence of shoe midsoles dynamic properties and ground stiffness on the impact force during running', *Computer Methods in Biomechanics and Biomedical Engineering*, 11:1, 149 — 150
- McMahon, T.A., Cheng, G.C., 1990. The mechanics of running: how does stiffness couple with speed? *Journal of Biomechanics* 23, 65-78.
- Nigg, B.M. 1983. In: Nigg, B.M., Kerr, B.A. (Eds), *External Force Measurements with Sport Shoes and Playing Surfaces*. University Printing, Calgary, 169-176.
- Nigg, B.M., Liu, W., 1999. The effect of the muscle stiffness and damping on simulated impact force peaks during running. *Journal of Biomechanics* 32, 849-856.
- Nigg, B.M., Stefanhyshyn, D., Cole, G., Stergiou, P., Miller, J., 2003. The effect of the material characteristics of shoe soles on muscle activation and energy aspects during running. *Journal of Biomechanics* 36, 569-575.
- Schlosser, F., 1983, *Eléments de mécanique des sols*, Presses de l'école nationale des ponts et chaussées, Paris.
- Snel, J.G., Delleman, N.J., Heerkens, Y.F., Ingen Schenau, G.J., 1985. In: Winter, D.A., Norman, R.W., Wells, R.P., Hayes, C., Patla, A.E. (Eds). *Shock Absorbing Characteristics of Running Shoes during Actual Running*. Human Kinetics Publisher, Champaign, IL, 133-138.
- Zadpoor, A.A., Nikooyan, A.A., 2006. A mechanical model to determine the influence of masses and mass distribution on the impact force during running – a discussion. *Journal of Biomechanics* 39, 388-390.
- Zadpoor, A.A., Nikooyan, A.A., Arshi, A.R., 2007. A model-based parametric study of impact force during running. *Journal of Biomechanics* 40, 2012-2021.

List of Tables

Table 1. The parameters (masses, spring constants, damping coefficients) of the system

Table 2. The parameters of vertical reaction force.

Table 3. Parameters of the original ground reaction force model, the modified ground reaction force model and the modified touchdown velocities.

Table 4. Properties of the studied soils

Table 5. Mechanical properties of studied shoes at 1.5 Hz

Table 6. Values of peak positive axial acceleration measured for shod running, after Lafortune (1991)

Table 7. Values of peak acceleration (mass m_1) as a function of the stiffness of the running surface

List of Figures

Figure 1

(a) A simplified spring-damper-mass model for the human body during a running step: lower body rigid mass (m_1) and wobbling mass (m_2); upper body rigid mass (m_3) and wobbling mass (m_4); compressive spring (k_1) and damper (c_1) that connect the upper and lower body rigid masses; spring (k_3) and spring-damper unit (k_2, c_2) connecting the lower wobbling mass to the upper and lower body rigid masses; spring (k_5) and spring-damper unit (k_4, c_4) connecting the upper wobbling mass to the upper rigid mass.

(b) A new spring-mass-damper model: shoe rigid mass (m_5); spring-damper unit (k_6, b_6, c_6) connecting the lower rigid mass to the shoe rigid mass; compressive spring (k_s) representing the ground stiffness

Figure 2

The indenter used for loading the shoe sole and the characterization of mechanical parameters.

Figure 3

Example of testing results for the determination of shoe mechanical parameters.

Figure 4

Ground reaction force F_g for soil S3 (Ground stiffness: 210 kN/m)

Figure 5

Ground reaction force F_g for soil S6 (Ground stiffness: 880 kN/m).

Figure 6

Shoe cushioning ($F_g - F_s$) for soil S3 (Ground stiffness: 210kN/m).

Figure 7

Shoe cushioning ($F_g - F_s$) for soil S6 (Ground stiffness: 880 kN/m).

Figure 8

(a) Influence of ground stiffness on the simulated vertical ground reaction force for hard shoes;
(b) Influence of ground stiffness on the simulated vertical ground reaction force for soft shoes.

Figure 9

(a) Evolution of the passive force peak according to the ground stiffness;
(b) Evolution of the loading rate according to the ground stiffness;
(c) Evolution of the maximum shoe cushioning ($F_g - F_s$) according to the ground stiffness;
(d) Evolution of the acceleration of m_1 according to the ground stiffness.

Figure 10

Acceleration of the mass m_1 (g) for soil S6 (Ground stiffness: 880 kN/m); load frequency 1.5 Hz.

Table 1. The parameters (masses, spring constants, damping coefficients) of the system

m_1	m_2	m_3	m_4	k_1	k_2	k	k_4	k_5	c_1	c_2	c_4
(kg)	(kg)	(kg)	(kg)	(kN/m)	(kN/m)	(kN/m)	(kN/m)	(kN/m)	(kg/s)	(kg/s)	(kg/s)
6.15	6	12.58	50.34	6	6	10	10	18	300	650	1900

Table 2. The parameters of vertical reaction force and touchdown velocities

	a	b	c	d	e
Soft shoe	$1.0 \cdot 10^6$	1.56	$2.0 \cdot 10^4$	0.73	1.0
Hard shoe	$1.0 \cdot 10^6$	1.38	$2.0 \cdot 10^4$	0.75	1.0

	m_1	m_2	m_3	m_4
Velocities	0.6 m/s	0.6 m/s	0.6 m/s	0.6 m/s

Table 3. The modified parameters of vertical reaction force and the modified touchdown velocities

	a	b	c	d	e
Soft shoe	$0.6 \cdot 10^6$	1.56	$2.0 \cdot 10^4$	0.73	1.0
Hard shoe	$0.6 \cdot 10^6$	1.38	$2.0 \cdot 10^4$	0.75	1.0

	m_1	m_2	m_3	m_4
Velocities	0.96 m/s	0.96 m/s	2.0 m/s	2.0 m/s

Table 4. Properties of the studied soils

Reference	Material	Min Young Modulus (MPa)	Max Young Modulus (MPa)	Mean Young Modulus (MPa)	Poisson ratio	Ground stiffness k_s (kN/m)
SETRA	BBTM			5500	0.3	
Schossler	S1: multilayer	Sand+ clay + gravel (cf. appendix A.)				99
Schossler	S2= S1 + 25mm BBTM					143
Bridge Software Institute	S3: Soft soil	3.59	7.18	5.39	0.4	210
Bridge Software Institute	S4= S3 + 25mm BBTM					359
Bridge Software Institute	S5: Medium soil	7.18	14.36	10.77	0.45	429
Bridge Software Institute	S6: Hard soil	14.36	28.73	21.55	0.5	880

Table 5. Mechanical properties of studied shoes at 1.5 Hz

Shoe	k_6 (N/m)	b_6	c_6 (Ns/m)
40 Asker C	2.22E+05	2.1679	9.14E+02
50 Asker C	2.18E+05	1.9519	1.37E+03
60 Asker C	3.62E+05	2.3018	1.87E+03
65 Asker C	4.03E+05	2.4346	2.17E+03

Table 6. Values of peak positive axial acceleration measured for shod running, after Lafortune (1991).

Authors	Velocity (m.s ⁻¹)	Surface	Acceleration (g)
Clarke et al. (1983)	3.8	Treadmill	6.9-7.41
Clarke et al. (1985a)	3.8	Treadmill	9.55
Clarke et al. (1985b)	3.35-5.36	Treadmill	6.2-10.7
Nigg et al. (1974)	Not reported	Various	6.0-11
Valiant (1990)	3.83	Treadmill	7.1
Lafortune (1991)	3.5-4.7	Treadmill	2.9-5

Table 7. Values of peak acceleration (mass m_1) as a function of the stiffness of the running surface

Ground stiffness (kN.m ⁻¹)	Acceleration (g)
99	2.34 – 4.03
143	2.91 – 5.13
210	3.6 – 6.54
359	4.51 – 8.53
429	4.97 – 9.56
880	6.31 – 13.04

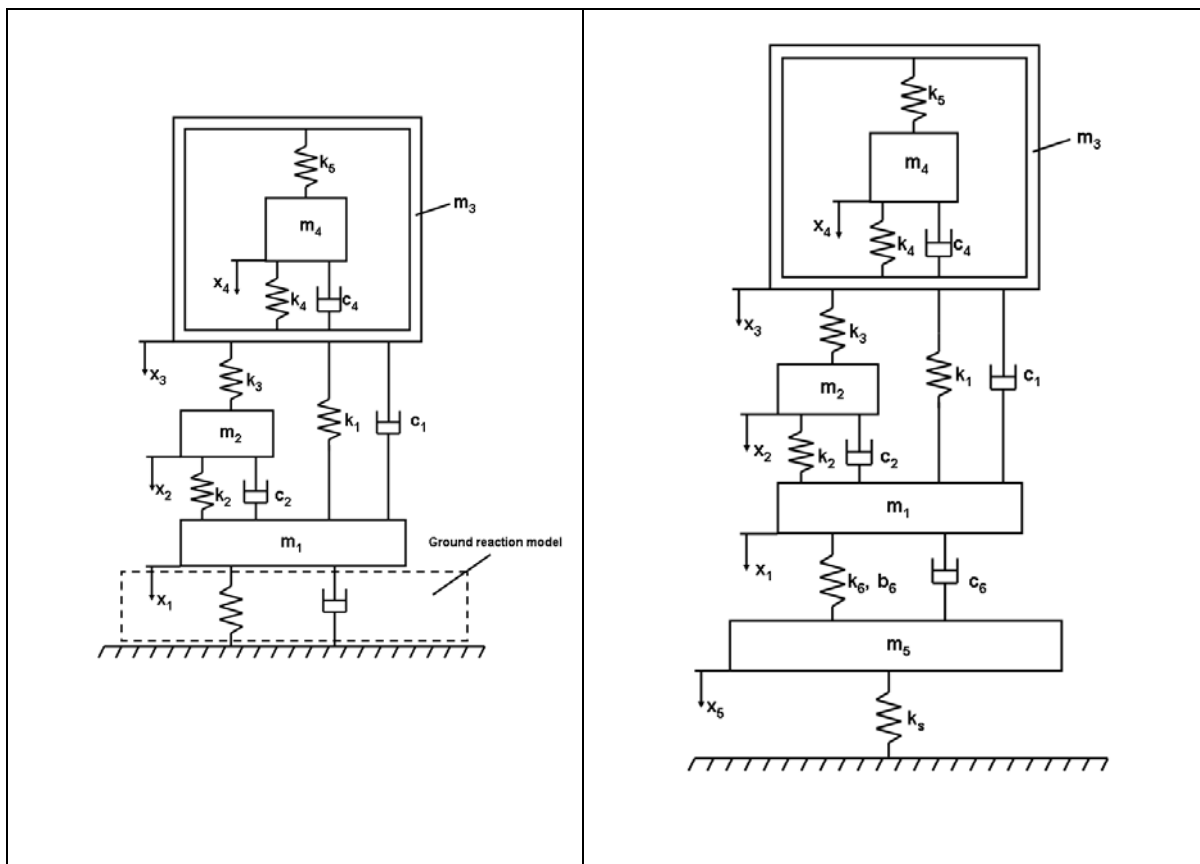

Figure 1

(a) A simplified spring-damper-mass model for the human body during a running step: lower body rigid mass (m_1) and wobbling mass (m_2); upper body rigid mass (m_3) and wobbling mass (m_4); compressive spring (k_1) and damper (c_1) that connect the upper and lower body rigid masses; spring (k_3) and spring-damper unit (k_2 , c_2) connecting the lower wobbling mass to the upper and lower body rigid masses; spring (k_5) and spring-damper unit (k_4 , c_4) connecting the upper wobbling mass to the upper rigid mass.

(b) A new spring-mass-damper model: shoe rigid mass (m_5); spring-damper unit (k_6 , b_6 , c_6) connecting the lower rigid mass to the shoe rigid mass; compressive spring (k_s) representing the ground stiffness

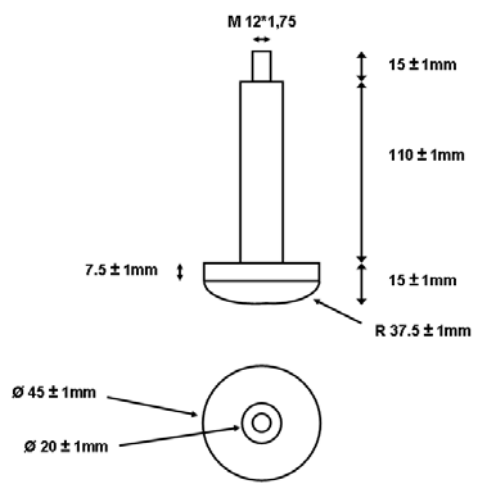

Figure 2
The indenter used for loading the shoe sole and the characterization of mechanical parameters.

Stabilized cycle at 1.5 Hz, sole hardness 65 Asker C

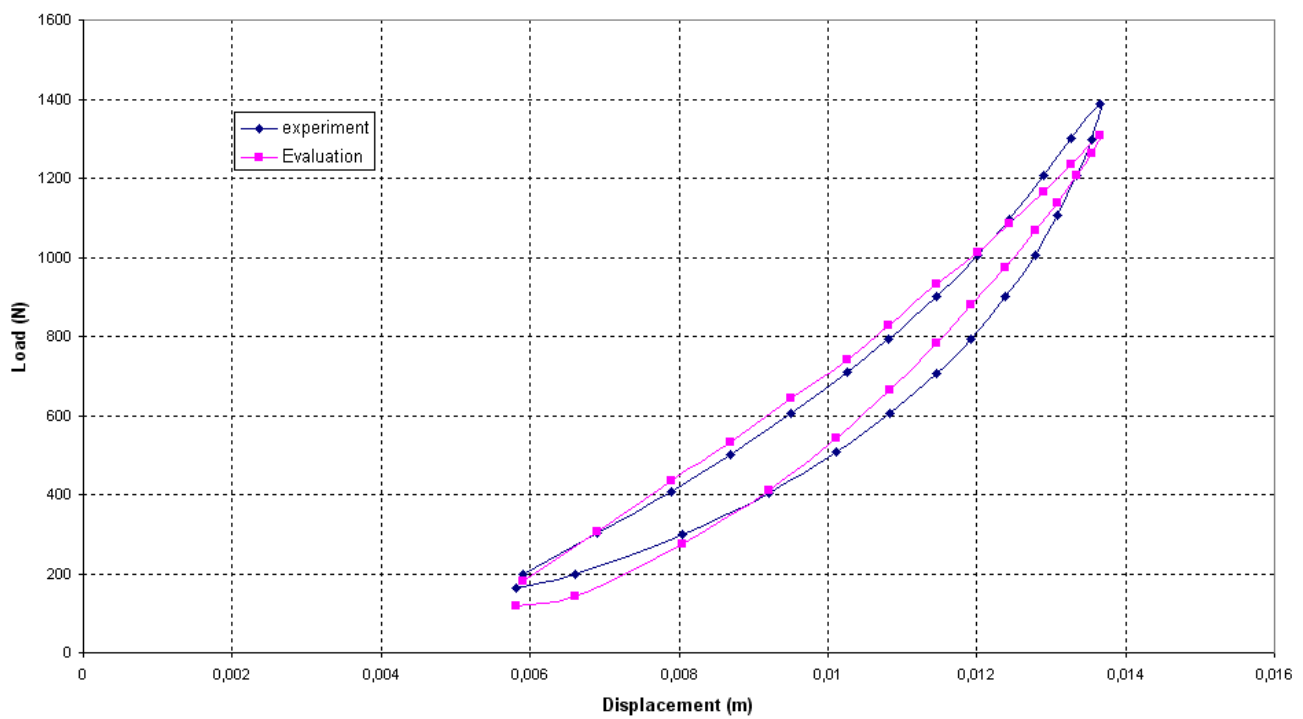

Figure 3
Example of testing results for the determination of shoe mechanical parameters.

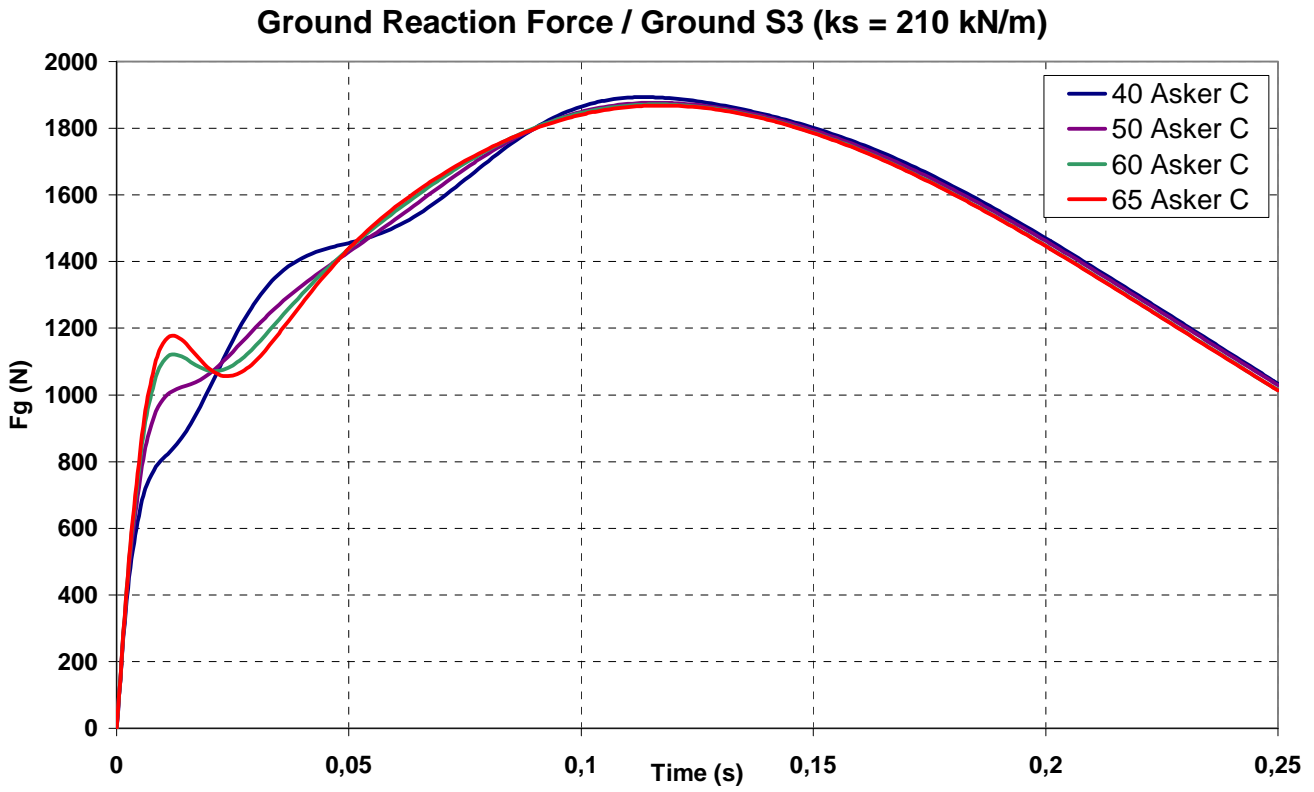

Figure 4
Ground reaction force F_g for soil S3 (Ground stiffness: 210 kN/m).

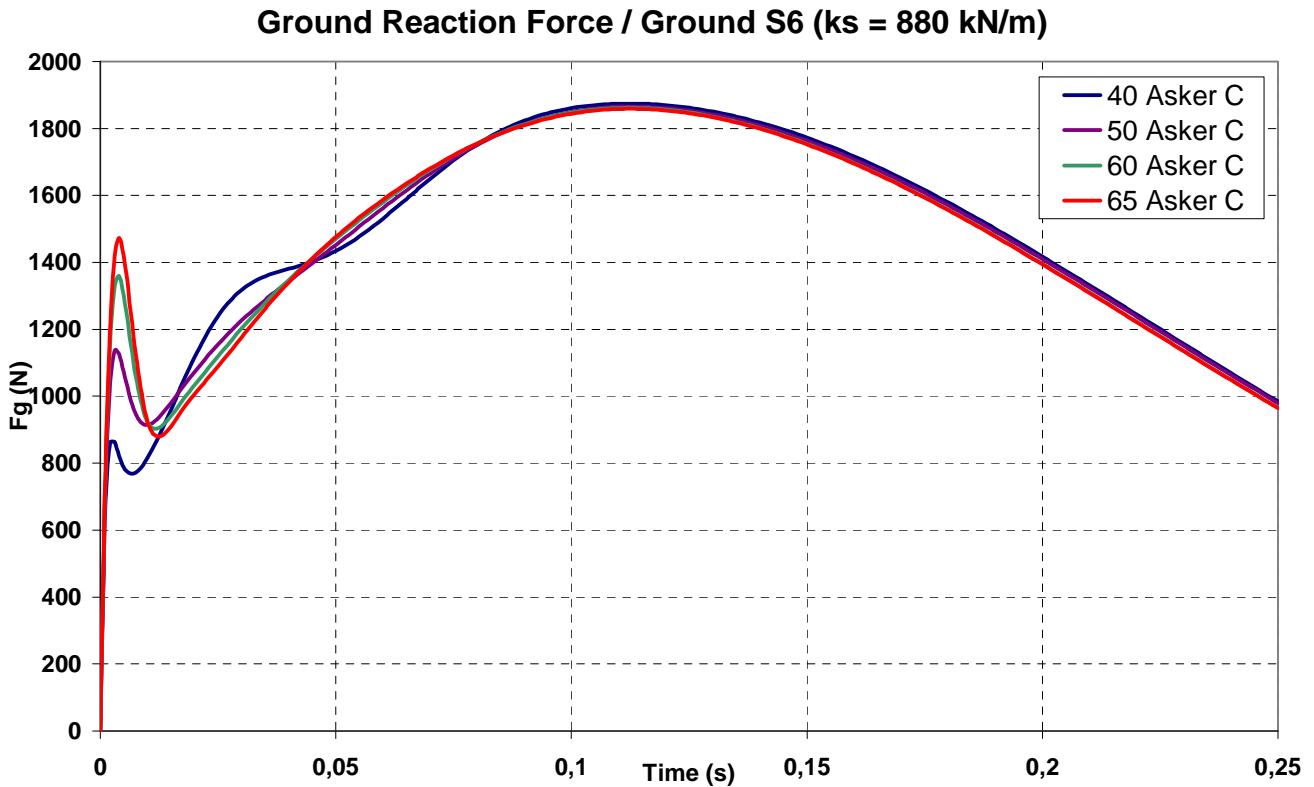

Figure 5
Ground reaction force F_g for soil S6 (Ground stiffness: 880 kN/m).

Fg-Fs / Ground S3 (ks = 210 kN/m)

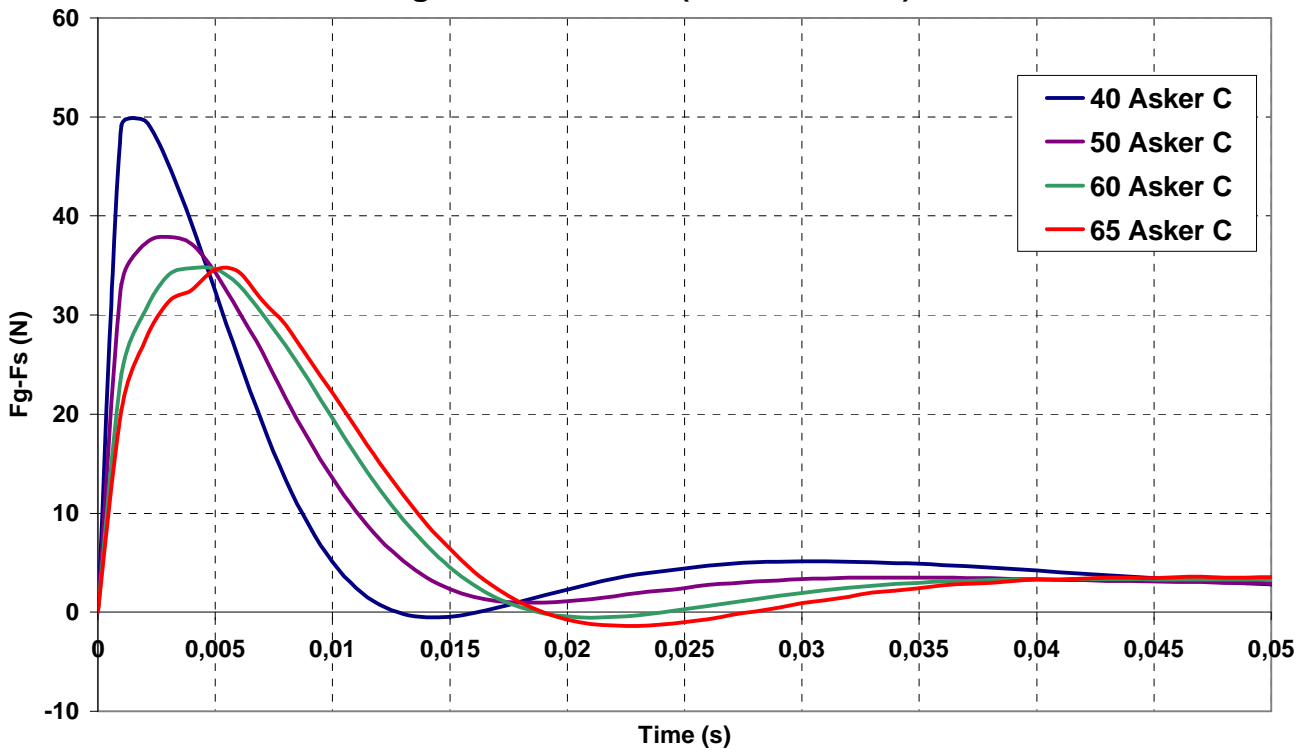

Figure 6
Shoe cushioning ($F_g - F_s$) for soil S3 (Ground stiffness: 210 kN/m).

Fg-Fs / Ground S6 (ks = 880 kN/m)

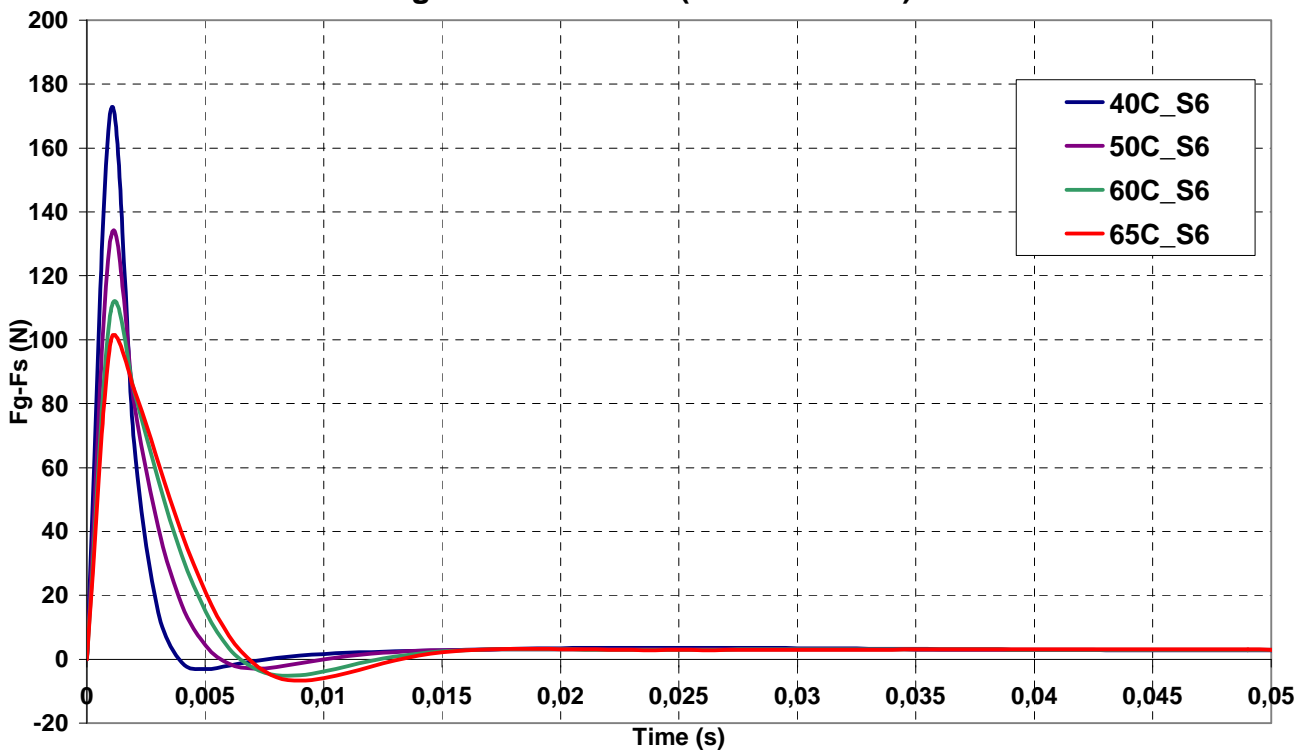

Figure 7
Shoe cushioning ($F_g - F_s$) for soil S6 (Ground stiffness: 880 kN/m).

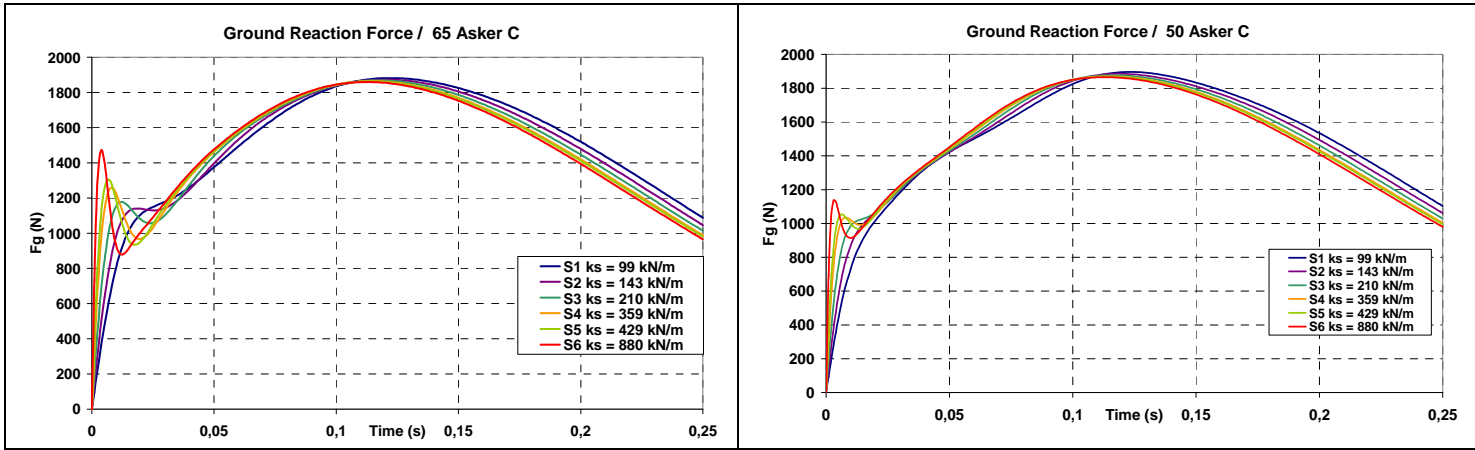

Figure 8
 (a) Influence of ground stiffness on the simulated vertical ground reaction force for hard shoes;
 (b) Influence of ground stiffness on the simulated vertical ground reaction force for soft shoes.

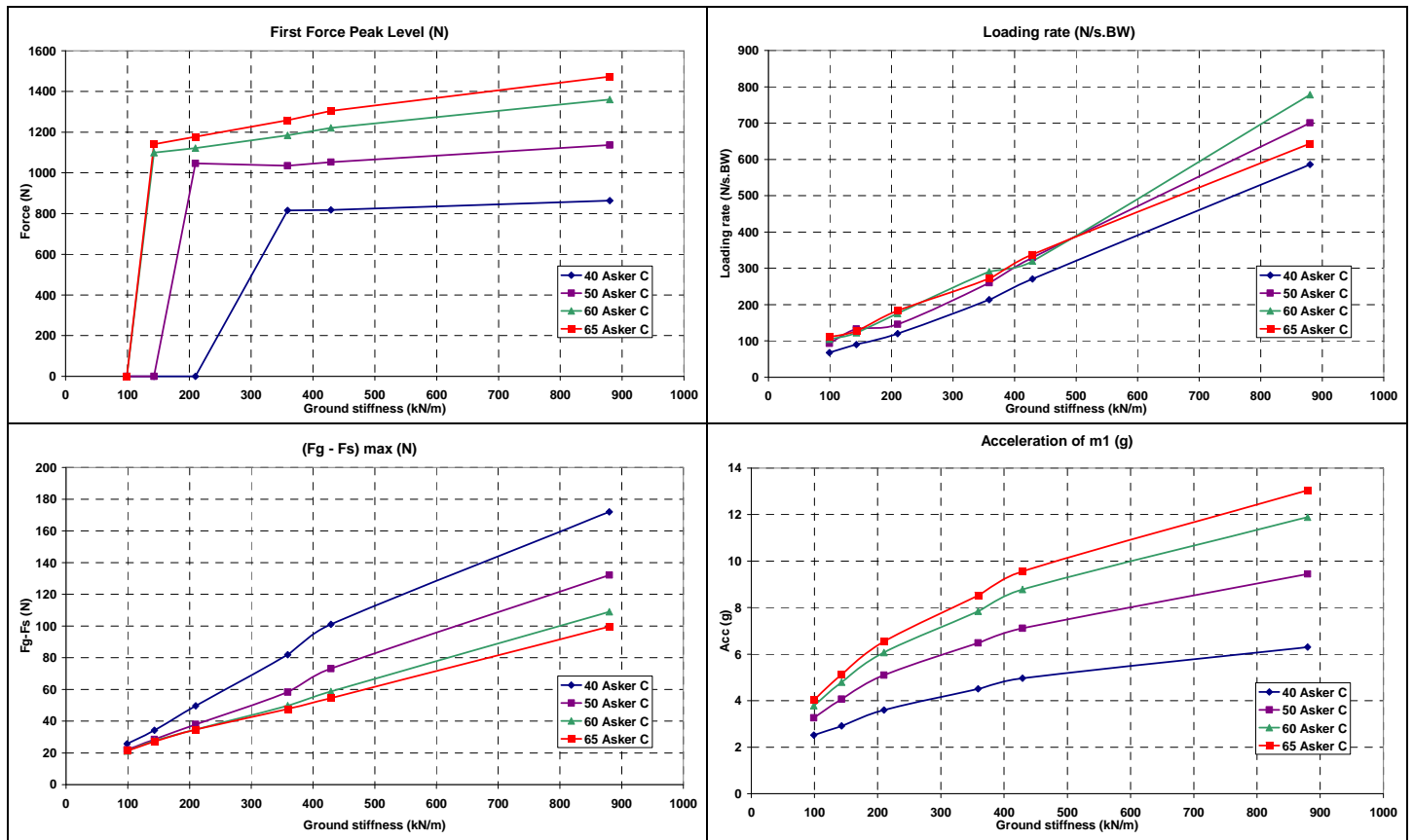

Figure 9
 (a) Evolution of the passive force peak according to the ground stiffness;
 (b) Evolution of the loading rate according to the ground stiffness;
 (c) Evolution of the maximum shoe cushioning ($F_g - F_s$) according to the ground stiffness;
 (d) Evolution of the acceleration of m_1 according to the ground stiffness.

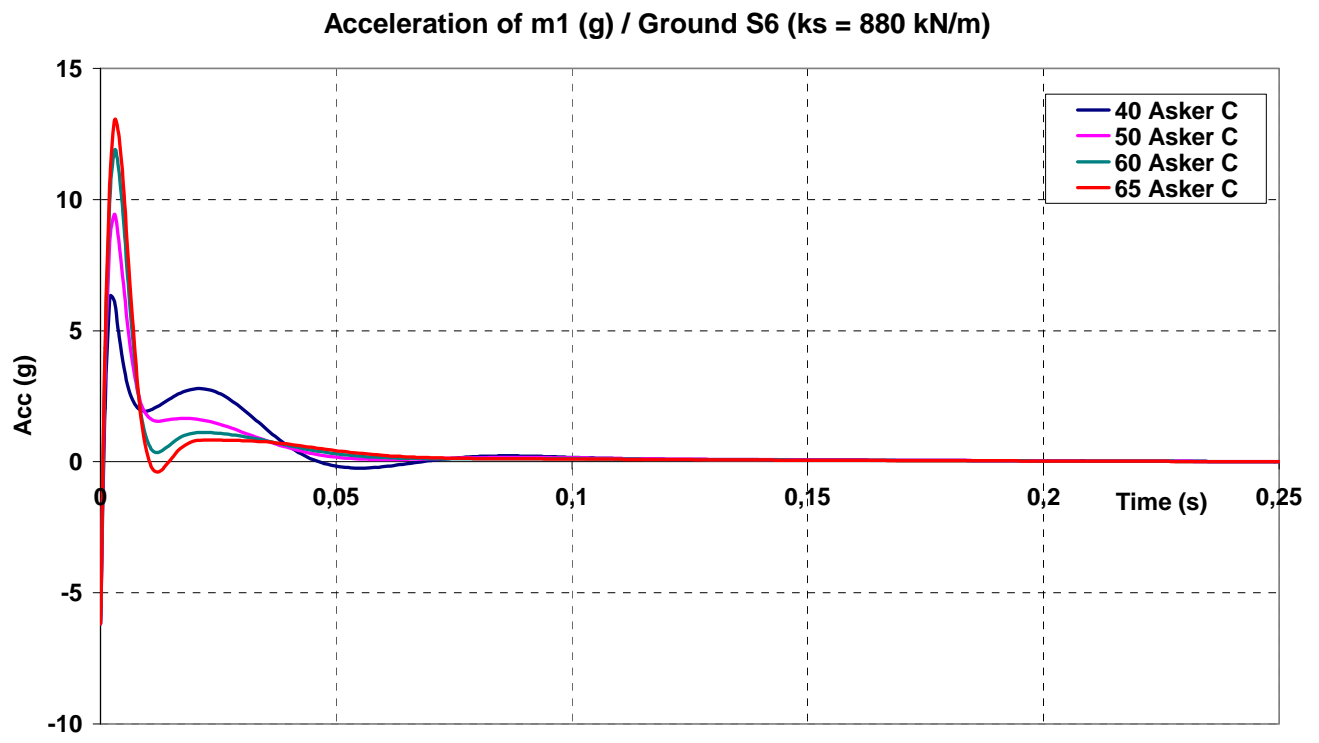

Figure 10
Acceleration of the mass m_1 [g] for soil S6 (ground stiffness $k_s = 880$ kN/m); load frequency 1.5 Hz.