

Spectrum Allocation Optimization Scheme for Heterogeneous Multiuser UWB systems

Ayman Khalil, Matthieu Crussière and Jean-François Hélard
Institute of Electronics and Telecommunications of Rennes (IETR)
INSA, 20 avenue des Buttes de Coësmes, 35043 Rennes, France
ayman.khalil@insa-rennes.fr

Abstract—In this paper, we investigate a new multiuser cross-layer approach for the resource allocation in the high rate ultra-wideband (UWB) systems. This cross-layer scheme is based on an optimization problem defined for the multiuser resource allocation. The new approach consists in combining information provided by the PHY and MAC layers in order to achieve an efficient and low-complexity sub-band allocation under quality of service (QoS) requirements. PHY level is responsible for providing the channel quality of each user by exploiting the effective SINR method, while the MAC level is in charge of classifying the existing users in order to differentiate between two major classes: hard-QoS and soft-QoS. The new low-complexity scheme performance is close to that of the optimal solution and it outperforms the single-user solution adopted by the multi-band UWB systems.

Keywords- UWB, OFDM, effective SINR, QoS, cross-layer.

I. INTRODUCTION

The ultra-wideband (UWB) is a promising technology for future home networks. In 2002, the Federal Communications Commission (FCC) regulated UWB systems by allocating the 3.1 to 10.6 GHz spectrum for unlicensed use [1]. Moreover, the FCC imposes a power spectral density of -41.3 dBm/MHz in order to avoid interference with other existing systems. Devices equipped with UWB transceivers can carry a wide set of multimedia applications such as videos, gaming, voice over IP, etc.

The IEEE 802.15.3a wireless personal area networks (WPAN) standardization group defined a very high data rate physical layer based on UWB signaling. One of the multiple-access techniques considered by the group is a multi-band orthogonal frequency division multiplexing (MB-OFDM) supported by the MultiBand OFDM Alliance (MBOA) and the WiMedia forum [2], [3], which merged in March 2005 and are today known as the WiMedia Alliance.

On December 2005, ECMA International approved two standards for UWB technology based on the WiMedia solution: ECMA-368 for high rate UWB PHY and MAC standard and ECMA-369 for MAC-PHY Interface for ECMA-368 [4].

To this date, resource allocations such as power control and channel allocation remain the topics of interest in multi-band

UWB systems. Most of the research studies that consider the resource allocation do not take into consideration the QoS requirements and the traffic differentiation issue in a multiuser environment. In [5], [6] for example, the authors propose resource allocation solutions for OFDM-UWB systems in a single-user scheme. In [7], the authors consider the multiuser context but without taking into consideration the users QoS requirements.

The aim of this paper is to propose a cross-layer sub-band allocation scheme for WiMedia systems in a heterogeneous multiuser context while respecting the MAC architecture of the ECMA standard. The basic idea is to dynamically allocate the sub-bands defined for UWB applications to the users demanding access to the network, taking into account both channel quality and QoS of each user. We first study the optimal solution by deriving a multiuser convex optimization problem. By analyzing the optimal solution and studying its characteristics and properties, we propose a low-complexity cross-layer solution that takes into consideration these properties but in a simple approach that agrees with the system distributed MAC architecture. This cross-layer scheme exploits jointly two aspects: the first is the effective SINR method assumed by the PHY layer in order to define the channel quality of each user in each sub-band. It consists in computing a single value that is correlated with the actual BER and that represents all the subcarriers forming the sub-band in order to have the required users channel information for the sub-band allocation. The second aspect is the QoS support provided by the MAC layer. This support is achieved by a service classifier function that differentiates between two service classes: the hard-QoS class for real-time applications (voice transmission, video streaming, gaming, etc) and the soft-QoS class for non real-time applications (Internet, file transfer, etc).

The remainder of this paper is organized as follows. Section II introduces the system model by presenting the PHY and MAC layers characteristics. Section III derives the problem formulation as a convex optimization problem and presents the optimal solution. In section IV, we give the proposed low-complexity cross-layer solution. Section V presents simulation results showing the comparison between the proposed scheme and the optimal solution, and the performance of the multiuser solution compared to the single-user WiMedia solution. Finally, section VI concludes this paper.

II. SYSTEM MODEL

A. PHY Layer

The WiMedia solution consists in combining OFDM with a multi-banding technique that divides the available band into 14 sub-bands of 528 MHz, as illustrated in Fig. 1. An OFDM signal can be transmitted on each sub-band using a 128-point inverse fast Fourier transform (IFFT). Out of the 128 subcarriers used, only 100 are assigned to transmit data. Different data rates from 53.3 to 480 Mbps are obtained through the use of forward error correction (FEC), frequency-domain spreading (FDS) and time-domain spreading (TDS), as presented in Table I. The constellation applied to the different subcarriers is either a quadrature phase-shift keying (QPSK) for the low data rates or a dual carrier modulation (DCM) for the high data rates. Time-frequency codes (TFC) are used to provide frequency hopping from a sub-band to another at the end of each OFDM symbol. TFC allows every user to benefit from frequency diversity over a bandwidth equal to the three sub-bands of one channel. λ is a scaling factor that depends on the selected modulation and coding scheme (MCS), it is used for the computation of the effective SINR.

The WiMedia solution offers potential advantages for high-rate UWB applications, such as the signal robustness against channel selectivity and the efficient exploitation of the energy of every signal received within the prefix margin [3].

B. MAC Layer

The WiMedia MAC protocol is a distributed TDMA-based MAC protocol as defined in ECMA standard. Time is divided into superframes where each frame is composed of 256 medium access slots (MAS) as illustrated in Fig. 2. Each MAS has a length of 256 μ s. Each superframe starts with a beacon period (BP) that is responsible for the exchange of reservation information, the establishment of neighbourhood information and many other functions.

WiMedia defines two access mechanisms: the prioritized contention access (PCA) and the distributed reservation protocol (DRP) [4].

PCA provides differentiated access to the medium for four access categories (ACs); it is similar to the enhanced distributed channel access (EDCA) mechanism of IEEE 802.11e standard. On the other hand, DRP is a TDMA-based mechanism which enables a device to reserve one or more MASs for the communication with neighbours.

ECMA defines two types of reservation: hard reservation and soft reservation. In the hard reservation case, devices other than the reservation owner and target(s) shall not transmit frames; that means that unused time should be released for PCA. On the other hand, the soft reservation type permits PCA, but the reservation owner has preferential access.

In brief, any of the defined mechanisms is based on an efficient service differentiation that can guarantee a certain level of QoS for strict QoS applications.

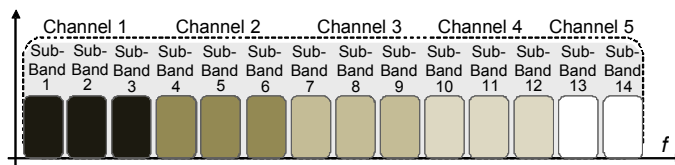

Figure 1. Channel distribution for WiMedia solution.

The main disadvantage of PCA mechanism is the collision that could happen between the users due to the use of random values to access the medium (backoff and contention window). On the other hand, DRP mechanism solves the problem of collision, but it is not based on a service differentiation principle.

In our work, since we consider service differentiation and QoS support, we are concerned to define a new mechanism based on the DRP principle regarding the negotiation and reservation, and capable at the same time to differentiate between the existing users. Furthermore, the proposed mechanism should be able to exploit the multi-band characteristics of the WiMedia solution at the PHY level allowing a sub-band spectrum sharing between users, as well as time slot allocation through scheduling principles.

III. ANALYTICAL STUDY

A. Channel Information

As described in the previous section, the allocation in WiMedia solution is made by sub-band as each channel is divided into three sub-bands and each sub-band contains 128 subcarriers. In order to compute each user channel power of each sub-band, we propose to use the effective SINR method to represent the characteristics of each sub-band and to evaluate the system level performance after channel decoding in terms of BER [8]. This can be motivated, from the physical layer point of view by the need of such measures for accurate and realistic evaluation of the system level performance but also for suitable development of link adaptation algorithms such as adaptive modulation and coding, packet scheduling, etc.

TABLE I. WIMEDIA SYSTEM DATA RATES

Data Rate (Mbps)	Modulation	Coding Rate	FDS	TDS	λ
53.3	QPSK	1/3	Yes	Yes	1.49
80	QPSK	1/2	Yes	Yes	1.57
110	QPSK	11/32	No	Yes	1.52
160	QPSK	1/2	No	Yes	1.57
200	QPSK	5/8	No	No	1.82
320	DCM	1/2	No	No	1.85
400	DCM	5/8	No	No	1.82
480	DCM	3/4	No	No	1.80

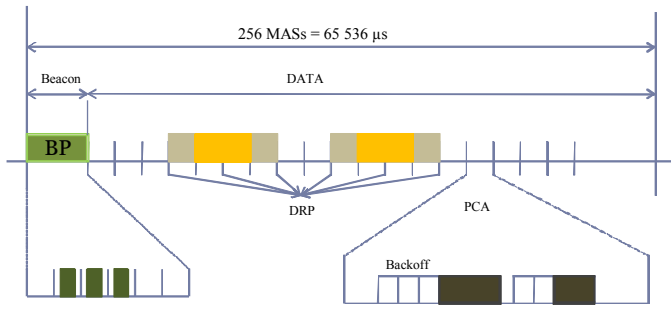

Figure 2. MAC superframe structure.

The effective SINR method consists in finding a compression function that maps the sequence of varying SINRs to a single value that is strongly correlated with the actual BER. If N is the number of subcarriers in a sub-band, the effective SINR is given by

$$SINR_{eff} = I^{-1} \left(\frac{1}{N} \sum_{i=1}^N I(SINR_i) \right) \quad (1)$$

In the effective SINR method, as in [8], we use the following information measure function $I(x)$

$$I(x) = \exp\left(-\frac{x}{\lambda}\right) \quad (2)$$

which inverse function I^{-1} is straightforwardly obtained. Thus

$$SINR_{eff} = -\lambda \ln \left[\frac{1}{N} \sum_{i=1}^N \exp\left(-\frac{SINR_i}{\lambda}\right) \right] \quad (3)$$

where $SINR_i$ is the ratio of signal to interference and noise for the i^{th} subcarrier and λ is a scaling factor that depends on the selected modulation and coding scheme (MCS). λ is computed and evaluated for the eight WiMedia data rate modes as shown in Table I.

In our system model, we compute the effective SINR value for each user in each sub-band by using (3). For instance, in the case of one channel divided into $N_b = 3$ sub-bands, and with $N_k = 3$ users, the computation result is a matrix containing $N_b \times N_k = 9$ effective SINR values.

B. Problem Formulation

The system consists of K users where the first K_h users are hard-QoS users and the remaining $K - K_h$ are soft-QoS users. The rate of a user k in a sub-band b is defined as

$$r_{k,b} = \log_2(1 + P_{k,b} \xi_{k,b}) \quad (4)$$

where $P_{k,b}$ is the allocated power of user k in the sub-band b ,

and $\xi_{k,b}$ is the effective SINR of user k in this sub-band.

The objective in this paper is to optimize the sub-band allocation under the total power constraint P_T so as to maximize the total data rate of $K - K_h$ soft-QoS users while maintaining a certain level of transmission rate for the K_h hard-QoS users. The problem can be formulated as

$$\begin{aligned} \max_{S_k} \quad & \sum_{k=K_h+1}^K \sum_{b \in S_k} r_{k,b} \\ \text{subject to} \quad & \sum_{b \in S_k} r_{k,b} \geq R_k, \quad k = 1, \dots, K_h \\ & \sum_{k=1}^K \sum_{b=1}^B P_{k,b} \leq P_T \end{aligned} \quad (5)$$

where B is total number of sub-bands, R_k is the hard-QoS user k required data rate, S_k is the set of sub-bands assigned to user k . In our case, S_1, S_2, \dots, S_{K_h} are disjoint and each user is assigned one sub-band during one time interval.

The first constraint in (5) ensures a given data rate for hard-QoS users while the second is the power limitation constraint. The formulated problem is a mixed integer programming problem which is hard to solve. However, we can convert this problem into a convex optimization problem by adopting a new parameter $\omega_{k,b}$ [9]. It represents a time-sharing factor for the user k of the sub-band b . The optimization problem is reformulated as

$$\begin{aligned} \max_{\omega_{k,b}, P_{k,b}} \quad & \sum_{k=K_h+1}^K \sum_{b=1}^B \omega_{k,b} \log_2 \left(1 + \frac{P_{k,b} \xi_{k,b}}{\omega_{k,b}} \right) \\ \text{subject to} \quad & \sum_{b=1}^B \omega_{k,b} \log_2 \left(1 + \frac{P_{k,b} \xi_{k,b}}{\omega_{k,b}} \right) \geq R_k, \quad k = 1, \dots, K_h \\ & \sum_{k=1}^K \omega_{k,b} = 1 \quad \forall b \quad 0 \leq \omega_{k,b} \leq 1 \quad \forall k, b \\ & \sum_{k=1}^K \sum_{b=1}^B P_{k,b} \leq P_T \end{aligned} \quad (6)$$

which is now a convex maximization problem. Using standard optimization techniques, we obtain the Lagrangian

$$\begin{aligned} L = \quad & \sum_{k=K_h+1}^K \sum_{b=1}^B \omega_{k,b} \log_2 \left(1 + \frac{P_{k,b} \xi_{k,b}}{\omega_{k,b}} \right) + \\ & \sum_{k=1}^{K_h} \alpha_k \left(\sum_{b=1}^B \omega_{k,b} \log_2 \left(1 + \frac{P_{k,b} \xi_{k,b}}{\omega_{k,b}} \right) - R_k \right) + \\ & \sum_{b=1}^B \beta_b \left(1 - \sum_{k=1}^K \omega_{k,b} \right) + \gamma \left(P_T - \sum_{k=1}^K \sum_{b=1}^B P_{k,b} \right) \end{aligned} \quad (7)$$

$P_{k,b}^*$ and $\omega_{k,b}^*$ are the optimal solution. After differentiating (7)

with respect to $P_{k,b}$ by KKT optimality condition, we obtain

$$P_{k,b}^* = \omega_{k,b} \left(\frac{1}{\gamma \ln 2} - \frac{1}{\xi_{k,b}} \right) \quad \text{for soft-QoS users} \quad (8)$$

$$P_{k,b}^* = \omega_{k,b} \left(\frac{\alpha_k}{\gamma \ln 2} - \frac{1}{\xi_{k,b}} \right) \quad \text{for hard-QoS users} \quad (9)$$

After differentiating (7) with respect to $\omega_{k,b}$ we obtain

$$\log_2 \left(\frac{\xi_{k,b}}{\gamma \ln 2} \right) - \frac{1}{\ln 2} \left(1 - \frac{\gamma \ln 2}{\xi_{k,b}} \right) - \beta_b = 0 \quad \text{for soft-QoS users} \quad (10)$$

$$\alpha_k \left[\log_2 \left(\frac{\alpha_k \xi_{k,b}}{\gamma \ln 2} \right) - \frac{1}{\ln 2} \left(1 - \frac{\gamma \ln 2}{\alpha_k \xi_{k,b}} \right) \right] - \beta_b = 0 \quad \text{for hard-QoS users} \quad (11)$$

Since $\omega_{k,b}^*$ should satisfy the following KKT condition

$$\frac{\partial L}{\partial \omega_{k,b}^*} = \begin{cases} > 0 & \omega_{k,b}^* = 1 \\ = 0 & \omega_{k,b}^* \in]0, 1[\\ < 0 & \omega_{k,b}^* = 0 \end{cases} \quad (12)$$

Substituting (10) and (11) in (12), we get

$$\omega_{k,b}^* = \begin{cases} 1 & C_{k,b} > \beta_b \\ 0 & C_{k,b} < \beta_b \end{cases} \quad (13)$$

where $C_{k,b}$ is defined as

$$C_{k,b} = \log_2 \left(\frac{\xi_{k,b}}{\gamma \ln 2} \right) - \frac{1}{\ln 2} \left(1 - \frac{\gamma \ln 2}{\xi_{k,b}} \right) \quad \text{for soft-QoS users} \quad (14)$$

$$C_{k,b} = \alpha_k \left[\log_2 \left(\frac{\alpha_k \xi_{k,b}}{\gamma \ln 2} \right) - \frac{1}{\ln 2} \left(1 - \frac{\gamma \ln 2}{\alpha_k \xi_{k,b}} \right) \right] \quad \text{for hard-QoS users} \quad (15)$$

We conclude that for each sub-band b , only the user with the greatest $C_{k,b}$ can use the sub-band. In other words, for a sub-band b , if $C_{k,b}$ are different for all k , then

$$\omega_{k',b}^* = 1, \quad \omega_{k,b}^* = 0 \quad \text{for all } k \neq k' \quad (16)$$

$$\text{where } k' = \arg \max_k C_{k,b} \quad (17)$$

In order to compute $C_{k,b}$ for all users, we need to find the set of α_k such that the hard-QoS rate constraints are satisfied.

Thus, an iterative searching algorithm is defined. We start with small values of α_k and we increase them with an iterative procedure until the data rate for all users are satisfied.

IV. CROSS-LAYER SOLUTION

The optimal solution presented in the previous section is not practical for two reasons: (i) it requires an intensive computation cost due to the iterative searching algorithm; (ii) it is too complex to be adopted in a distributed architecture that requires a frequent exchange of information between devices.

In our system, there is no central coordinator that is charged for the spectrum sharing and the allocation decision for the devices. Every device should have a self mechanism capable of defining the basic requirements in order to send them to other existing devices via the beacons where the allocation decision should be taken.

By analyzing the optimal solution and studying its properties, we note that the function $C_{k,b}$ is monotonically increasing with respect to two parameters: $\xi_{k,b}$ and α_k in the hard-QoS users case. From this observation, we propose to define a simple algorithm that reduces the complexity of the optimal solution and that is based on a cross-layer approach. This algorithm considers the combination of two metrics, each computed at a level. The first metric is the $\xi_{k,b}$ computed by each user at the PHY level, and the second metric which has the same properties of α_k but computed differently is the weight of the user k defined at the MAC layer. This weight noted q_k represents the priority level of user k which is function of its service class and its QoS requirements (data rate, error rate, etc). The algorithm can be described as

1) Assigning the weight in a way that respects the following conditions

$$\begin{cases} \sum_{k=1}^K q_k = 1 \\ q_{hard-QoS} = \rho \times q_{soft-QoS} \end{cases} \quad (18)$$

where ρ is a positive constant greater than one which value depends on the ratio of hard-QoS users number to soft-QoS users number. For instance, if we have two hard-QoS users and one soft-QoS user, the weights of the hard-QoS users are equal to 0.4 while the weight of the soft-QoS user is equal to 0.2.

2) Defining the cross-layer allocation function

$$\tilde{C}_{k,b} = q_k \times \xi_{k,b} \quad (19)$$

3) Classifying the users

The allocation is now made in a priority-based approach. Thus, each user k defines first its allocation level (AL) which is

its greatest $\tilde{C}_{k,b}$ value. Then, the highest priority user (i.e. the user having the greatest AL) is assigned the most powerful sub-band (the greatest $\xi_{k,b}$).

4) Sharing the allocation information in the distributed architecture

In the distributed architecture, the AL is transmitted by the user having traffic to send to all the existing users in its piconet via the information elements (IEs) used in the BP as given in ECMA standard. Moreover, each user k determines its sub-band sequence in a preferred order based on the computation of $\xi_{k,b}$ for each b , so that each user is aware of all other users conditions. Consequently, at each superframe, the sub-bands are allocated according to the AL and the sub-band sequences computed by each user; for example, [2 3 1] is a sub-band sequence for a user having the highest power (greatest $\xi_{k,b}$) in sub-band 2 and the lowest power in sub-band 1.

5) Scheduling and negotiating

The negotiation takes place whenever two or more users choose the same sub-band. In this case, the first priority user, i.e. the user that has the greatest AL is assigned its highest priority sub-band, and the second priority user has to choose its second highest priority sub-band and so on. After the negotiation, the reservation of MASs is performed with the same manner as in the DRP mechanism.

The main advantage of the new cross-layer solution is that it reduces the complexity of the optimal solution by substituting the iterative mechanism by a simple service classifier function. Besides, the allocation is updated at the beginning of each superframe. Accordingly, this allocation strategy is useful and can be efficiently applied for indoor UWB communications without significantly increasing the system complexity, thanks to the slow time variations of the UWB channel.

V. SYSTEM PERFORMANCE

A. Channel Model

The channel used in this study is the one adopted by the IEEE 802.15.3a committee for the evaluation of UWB physical layer proposals [10].

TABLE II. CHARACTERISTICS OF UWB CHANNEL

	CM1	CM2	CM3	CM4
Mean excess delay (ns)	5.05	10.38	14.08	-
RMS delay spread (ns)	5.28	8.03	14.28	25
Distance (m)	<4	<4	4-10	10
LOS/NLOS	LOS	NLOS	NLOS	NLOS

This model is a modified version of Saleh-Valenzuela model for indoor channels [11], fitting the properties of UWB channels. A log-normal distribution is used for the multipath gain magnitude. In addition, independent fading is assumed for each cluster and each ray within the cluster. The impulse response of the multipath model is given by

$$h_i(t) = G_i \sum_{z=0}^{Z_i} \sum_{p=0}^{P_i} \alpha_i(z, p) \delta(t - T_i(z) - \tau_i(z, p)) \quad (20)$$

where G_i is the log-normal shadowing of the i^{th} channel realization, $T_i(z)$ the delay of cluster z , and $\alpha_i(z, p)$ and $\tau_i(z, p)$ represent the gain and the delay of multipath p within cluster z , respectively.

Four different channel models (CM1 to CM4) are defined for the UWB system modelling, each with arrival rates and decay factors chosen to match different usage scenarios and to fit line-of-sight (LOS) and non-line-of-sight (NLOS) cases. The channel models characteristics are presented in Table II.

B. Simulation Results

In this section, we present the simulation results for the proposed multiuser cross-layer allocation scheme and we compare the performance of the new scheme with that of the optimal solution as well as the single-user WiMedia solution using TFC. Therefore, we use the proposed WiMedia data rates (see Table I). The results are performed on the first three WiMedia sub-bands (3.1- 4.7 GHz) for CM1 channel model.

In Fig. 3, we present the satisfaction of soft-QoS users in the optimal and the proposed cross-layer solutions. We define a user k satisfaction index η_k the ratio of its assigned sub-band b power $\tilde{\xi}_{k,b}$ to its most powerful sub-band.

$$\eta_k = \frac{\tilde{\xi}_{k,b}}{\max_b(\xi_{k,b})} \quad (21)$$

While the satisfaction index for hard-QoS users is equal to one in the optimal and cross-layer solutions, soft-QoS users satisfaction index varies according to their data rates. This is due to the fact that the power of users is represented by the effective SINR which depends on the data rate by means of λ parameter (see table I). Note that soft-QoS users data rate is limited to 200 Mbps, which is the hard-QoS users minimum required data rate (the value of R_k in (5)). As shown in the figure, the performance of the cross-layer solution is close to that of the optimal solution previously defined.

In Fig. 4, we compare the performance of a hard-QoS user transmitting at a rate of 320 Mbps in the cross-layer solution to that in the optimal solution and to the single-user WiMedia solution with TFC. Note that for the single-user solution TFC is exploited because it offers better performance. As shown in the figure, for a $BER = 10^{-4}$, the cross-layer and the optimal solutions are too close and offer a 2.5 dB gain for the hard-QoS user compared to WiMedia solution.

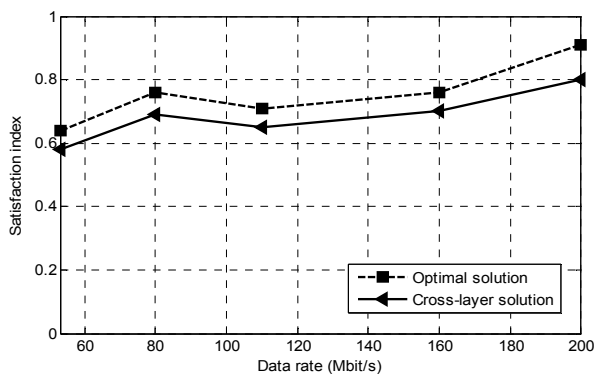

Figure 3. Satisfaction level of soft-QoS users in different WiMedia data rates.

In Fig. 5, we consider the case of soft-QoS users transmitting at a rate of 200 Mbps and present their performance in the optimal and cross-layer solutions. For a $BER = 10^{-4}$, the optimal solution offers a 0.5 dB compared to the cross-layer solution. On the other hand, we note that the performance of the cross-layer in the case of soft-QoS users is close to that of the single-user WiMedia solution. This proves that the performance of the multiuser cross-layer solution performance is never degraded compared to the single-user WiMedia solution.

VI. CONCLUSION

In this paper, we studied the multi-band UWB systems and the resource allocation problem in a heterogeneous multiuser context where the users are classified into two service classes: hard-QoS and soft-QoS. We presented an analytical study of the allocation problem and showed that the optimal solution is too complex to be adopted by the WiMedia solution due to the distributed MAC architecture. Hence, we proposed a simple cross-layer solution that reduces the complexity of the optimal solution and combines information provided by the PHY and MAC layer in order to ensure an efficient allocation that is close to the optimal one. Simulation results showed that the multiuser cross-layer solution outperforms the single-user WiMedia solution and that the soft-QoS users satisfaction in the cross-layer solution is close to that in the optimal case while the hard-QoS users have the same performance in both solutions.

ACKNOWLEDGMENT

The research leading to these results has received funding from the European Community's Seventh Framework Programme FP7/2007-2013 under grant agreement n° 213311 also referred as OMEGA.

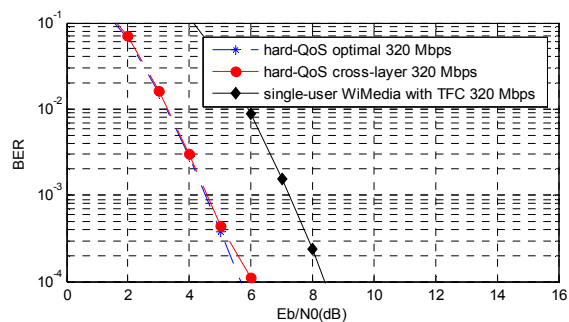

Figure 4. Hard-QoS users performance comparison.

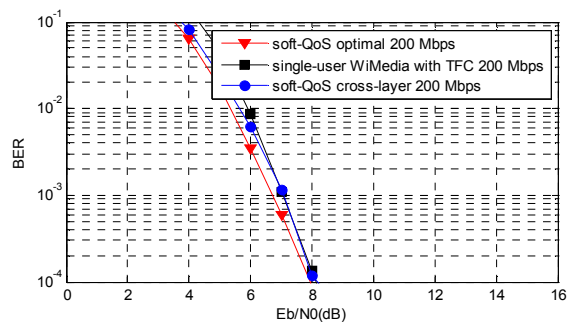

Figure 5. Soft-QoS users performance comparison.

REFERENCES

- [1] "First report and order, revision of part 15 of the commission's rules regarding ultra-wideband transmission systems," FCC, ET Docket 98-153, Feb. 14, 2002.
- [2] Batra *et al.*, "Multi-Band OFDM physical layer proposal for IEEE 802.15 task group 3a," IEEE document P802.15-04/0493r1, Texas Instruments *et al.*, Sept. 2004.
- [3] WiMedia Alliance, Inc., "Multiband OFDM physical layer specification," Release 1.1, July 2005.
- [4] Standard ECMA-368, High rate ultra wideband PHY and MAC standard, 2nd edition, Sept. 2007.
- [5] Z. Chen, D. Wang and G. Ding, "An OFDM-UWB Scheme with Adaptive Carrier Selection and Power Allocation," in *Proc. IEEE Intern. Conference on Wireless Communications, Networking and Mobile Computing (WiCOM '06)*, pp.1-4, China, Sept. 2006.
- [6] A. Stephan, J-Y. Baudais and J-F. Helard, "Efficient Allocation Algorithms for Multicarrier Spread Spectrum schemes in UWB applications," in *Proc. IEEE Intern. Conference on Ultra-Wideband (ICUWB '07)*, pp. 551-555, Singapore, Sept. 2007.
- [7] W.P. Siriwongpairat, Z. Han and K. J Ray Liu, "Power controlled channel allocation for multi-user multiband UWB systems," *IEEE Trans. Wireless Communications*, vol. 6, no. 2, pp. 583-592, Feb. 2007.
- [8] 3GPP TSG-RAN-1, "R1-030999: considerations on the system-performance evaluation of HSDP using OFDM modulations"; RAN WG1 #34.
- [9] P. W. C. Chan and R. S. Cheng, "Optimal power allocation in zero-forcing MIMO-OFDM downlink with multiuser diversity," in *Proc. of IST Mobile & Wireless Communications Summit*, Dresden, June 2005.
- [10] J. Foester, "Channel Modeling sub-committee report (final)," IEEE P802.15.-02/490r1-SG3a,2003.
- [11] Saleh and R. Valenzuela, "A statistical model for indoor multipath propagation," *IEEE J. on Selected Areas in Communications*, vol. 5, no. 2, pp. 128-137, Feb. 1987.