

Video Adaptation Acceleration in a Home Networking Context

W. Aubry, D. Négru

LaBRI – University of Bordeaux 1, France
{aubry, negru}@labri.fr

P. Kadionik

IMS – University of Bordeaux 1, France
kadionik@ims-bordeaux.fr

I. INTRODUCTION

Nowadays, service providers offer triple play services - TV, Internet and Telephony - to their consumers. In order to grant this service offer, they are using a home gateway device and its related technologies. The primary role of the Home Gateway consists of interconnecting the home network with the operator's network, permitting to serve the home end-users with a plethora of services.

With the growing multiplicity of available media sources and terminals, users will not be satisfied unless they get the ability to receive media coming from any multimedia source, on any of their devices at home. This nonetheless requires adapting the video content to these devices' capabilities by the so-called Home Gateways that, until now, only perform networking and management functionalities.

Due to the wide variety of digital video products, it is hardly possible to achieve such adaptation efficiently. New techniques have arisen allowing the adaptation of multimedia content, among which dynamic FPGA reconfiguration techniques are of major importance towards providing an on-the-spot reconfigurable hardware accelerator for multimedia processing ([1] et [2]). Thanks to such an FPGA solution introduced inside the Home Gateway, efficient dynamic adaptation of numerous video flows can thus be realized.

The paper introduces the premises of the proposed concept for performing efficient service adaptation inside a Home Gateway according to the users' requests. It relies on a FPGA reconfiguration technique aimed to react dynamically to the service demands.

The next section introduces the proposed solution, along with conception considerations and the envisaged architecture.

II. HOME GATEWAY WITH ADAPTATION FUNCTIONS

A. Concept presentation

In today's world, connectivity has to be done in the simplest possible way, in a "plug and play" manner. Customers do not want to worry about how to configure their devices to get it done. Thus, in a server/client based network, the server should adapt itself to the client, sending data that are relevant for the client terminal. The adaptation is done by looking for information about what can handle the client terminal and by computing data in order to fit the parameters. In the video field, relevant information are frame rate (number of frame per

second), resolution (number of pixel in a frame), bit rate (number of information for the video per second = quality), codec (compression/decompression algorithms) and format (video encapsulation and specification).

For each change in the video characteristics, there is a transformation process such as: transcoding to obtain a video encoded from a codec to another codec, or resizing to change the video resolution.

In the current Internet, it would be a hard task to enable this feature inside the existing servers, especially for those delivering video content. Our solution is to delegate the adaptation functions to the Home Gateway, present in each user's home, making the Home Gateway become a "relay" server, processing high-level tasks to the requested services. Therefore, the Home Gateway will be capable of delivering any multimedia content to any device, destined to one/multiple users, fully leveraging the current and future media coding formats, appliances and computing devices present in the user's environment. In order to stream or display an adapted video content to the requesting device, a Home Gateway may have to perform one or several tasks, such as transcoding, transrating and/or scaling the video content. For performing these tasks efficiently, it relies on hardware processing based on FPGAs. Upon reception of the video stream, the Home Gateway will instantiate the needed adaptation modules to send an adapted video and reconfigure this module into the FPGA. Finally, the Home Gateway will start streaming the adapted video content towards the user's device, according to the user's request and its overall context. Figure 1 depicts the overall concept explained above of a Home Gateway with adaptation functions.

B. Conception considerations

Video coding is requiring high processing power. Therefore, the Home Gateway must have high processing capabilities. In order to create such home gateway, a first approach is to build a home gateway in an all software manner and then search for what has to be improved. For that purpose, a fully equipped PC-based platform is deployed, with the following characteristics: a dual core x86 processor and a 2GB RAM and implementing the `ffmpeg` transcoding tool. Preliminary scalability tests have been driven on it on the transcoding power. Results show that 3 video transcoding from `mpeg2` to

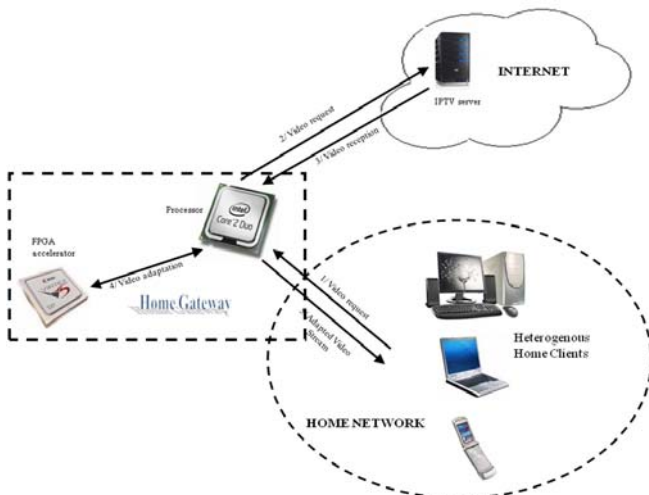

Figure 1: Concept Presentation

mpeg4 takes 100% of the CPU. With such a server, if 3 persons in the home network need a video stream that requires an adaptation, the computer will use up to every resources it has to adapt video and other services will be unavailable.

There is a need to lighten the load on the processor to achieve a better service quality and repartition in order to serve more clients. A solution can be achieved by accelerating tasks that require high computing resources and the best way is to use co-processing hardware accelerators that are specifically designed for speeding calculations ([3]). The co-processor is a chip apart from the main CPU dedicated to services treatment, in our case, video adaptation. The co-processing unit that will compute video adaptation will do it faster than the main CPU because it will be dedicated to this task. Thus, the gain in computing speed will be not only the difference between the CPU performance and the co-processor performance, but also the fact that the CPU can process another task while the co-processor is dealing with the video adaptation.

C. Architecture proposed

The co-design solution involving the use of both hardware and software in the architecture is the direction of our solution. The software flexibility will be used in order to deal with network protocol and the selection of which adaptation to do. The hardware speed will be used in order to deal with performances during the video adaptation process. The software part of the architecture will allow easy update to the gateway and will be less expensive in development time especially for taking decision task – what to adapt, where to redirect the stream ...- which is not the field of hardware architecture.

But if specialized hardware accelerator is not flexible enough, the updating issue will keep on existing. The path we decided to take is the use of co-design technique for accelerator itself by using FPGA circuits.

Our architecture focuses on the transcoding part of video adaptation and is shown in figure 2. The architecture is composed of a general purpose processor, an FPGA and

memory that stores software, data and FPGA configuration files. Upon a video transcoding demand, the processor will configure the FPGA using the right configuration file and send the video stream to the FPGA when configured. The FPGA will work out the transcoding process and send the newly coded video stream to the CPU that will send it to the requiring client. During the transcoding process, the CPU does not have to handle a single part and is free to process other required services at the same time.

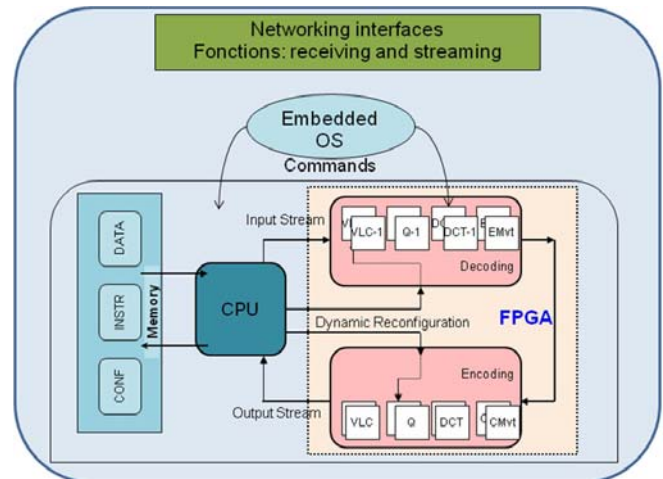

Figure 2: Home Gateway Hardware Architecture

III. CONCLUSION

Our work is about to find the right architecture that can handle common home gateway services and adapt video stream to any terminal. This architecture will use FPGA accelerator that will be configured with the proper video codec considering the adaptation required.

A first step will be to create such architecture and to work out tests to measure the performance gains compared to an all software solution. Then, the dynamic reconfiguration field will be explored in order to increase performances while dealing with multiple flows and reconfiguration on the spot.

REFERENCES

- [1] Y.Berviller, O.Perez, S.Weber "A modelling of the flexibility of on RTR-FGPA implementation in comparison to a software implementation " DASIP 2007 European Workshop on design and Architectures for signal and image processing Nov 27-29 2007 Grenoble Nov 27-29 2007
- [2] H. Taghipour, J. Frounchi and M. Hossein Zarifi, "Design and Implementation of MP3 Decoder using Partial Dynamic Reconfiguration on Virtex-4 FPGAs", in the proceedings of the International Conference on Computer and Communication Engineering, ICCCE'08, May 2008
- [3] Ben Atitallah A., Kadionik P., Masmoudi N., Lévi H "FPGA implementation of a HW/SW platform for multimedia embedded systems" Design Automation for Embedded Systems Journal pp 293-311. 2008