

# SOFTWARE AND HARDWARE IMPLEMENTS FOR TRACKING LOW EARTH ORBIT (LEO) SATELLITES

---

**Wassila Leila RAHAL, Nouredine BENABADJI and Ahmed Hafid BELBACHIR**

*Laboratory of Analysis and Applications of Radiations  
University of Sciences and Technology of Oran  
B.P. 1505 , El M'nouar, Oran, Algeria  
Tel/Fax: 213-41-53-04-61*

*Email: wassilaleila@hotmail.com, benanour2000@yahoo.com, ahbelbachir@yahoo.com*

---

Soumis le 24 janvier 2008 ; révisé le 15 avril 2008 ; accepté le 2 juin 2008, © *Revue Télédétection*, 2008, vol. 8, n° 2, p. 137-146

---

## **Abstract**

*In this paper, we present a novel, precise and efficient tracking system for Low Earth Orbit (LEO) Satellites. We have developed a software (LAAR-Track) and a hardware interface for orbit determination based on using orbital elements, which are given by the NORAD (North American Aerospace Defence). Orbital perturbations, such as the atmospheric drag, the influence of the moon and the sun and the geopotential field have been considered for satellites trajectory determination.*

*The LAAR-Track gives the azimuth and the elevation to the antenna for pointing in real time the LEO satellites. This software is loaded on a computer directly connected, via the parallel port, to a modified tracking interface, originally designed by XQ2FOD, and which will be detailed in this paper. By this way the antenna can be automatically directed for receiving NOAA (National Oceanic and Atmospheric Administration) HRPT (High Resolution Picture Transmission) pictures.*

**Keywords :** *LEO satellites, orbital perturbations, NOAA HRPT pictures, prevision and tracking satellites, TLE, SGP4 model.*

## **REALISATION LOGICIELLE ET MATERIELLE D'UN SYSTEME DE POURSUITE DES SATELLITES EN ORBITE BASSE (LEO)**

### **Résumé**

*Dans cet article, nous présentons un système pour le suivi en temps réel des satellites en basse orbite (LEO). Nous avons développé une interface matérielle de poursuite et un logiciel (LAAR-Track) pour la prévision de passage des satellites.*

*Le logiciel LAAR-Track, installé sur un PC, donne l'azimut et l'élévation que doit avoir l'antenne pour pointer en temps réel les satellites en visibilité directe de la station de réception.*

*Pour effectuer la poursuite automatique, l'interface que l'on a réalisé en s'inspirant du schéma initialement conçu par XQ2FOD, doit être reliée d'un côté au pupitre de commande du rotor de l'antenne, et de l'autre, au PC qui réalise la prévision de passage des satellites.*

*De cette manière, l'antenne peut être automatiquement orientée pour recevoir les images NOAA (National Oceanic and Atmospheric Administration) au format HRPT (High Resolution Picture Transmission).*

**Mots clés :** *Satellites LEO, perturbations orbitales, images NOAA HRPT, prévision et poursuite, éléments orbitaux, TLE, modèle SGP4.*

## 1. INTRODUCTION

The problem of satellite orbit determination is a very important one, especially for defiling satellites such as NOAA series. The need of using an automatic system of reception has become necessary because of the high transmission frequency of NOAA HRPT images (~1 Ghz), and hence, the opening angle of the antenna is low (~10 °), which makes the risk of loss of signal important.

General perturbations element sets are generated by NORAD for all resident space objects. These element sets are periodically refined so as to maintain a reasonable prediction capability on all space objects, and can be used to predict position and velocity of Earth-orbiting objects. To do this one must be careful to use a prediction method which is compatible with the way in which the elements were generated.

The orbit determination problem consists of two basic parts: Propagation of the state estimated forward in time and updating the state estimate based upon new measurements of parameters which are function of the states.

As we are interested by the HRPT images of NOAA satellites, we have chosen to predict the position of the satellites by using the SGP4 model, applied for near-Earth satellites.

## 2. THE PREDICTION MODELS (Hoots, 1980)

Satellite orbits around the Earth are not the perfect ellipses from Newtonian mechanics. The oblateness of the Earth, the irregular gravitational field, atmospheric drag, the pull of the Moon and Sun, and solar light pressure all effect satellites. Accurate models take into account these perturbations to predict where a satellite will be and what path it will follow.

When orbital elements are generated from observations a particular model is used. The elements released are the mean elements and are meant to be used with a particular model. Blindly converting to a different format or using a different model results in decreased accuracy. The most accuracy is achieved when using the same model as used to generate the elements.

The accuracy of element sets also depends on time. The perturbations change the orbit in non-predictable ways over long periods of time. This means that accuracy of the predictions from an element set decrease over time. The most accuracy requires getting fresh element sets. Atmospheric drag is the least predictable factor. This affects lower satellites more and makes their orbits less predictable which mean that the elements need to be updated more frequently to be accurate.

### 2.1. The sgp4 propagator ( Hilton and Kuhlman, 1966)

SGP4 (Simplified General Perturbations Satellite Orbit Model 4) is a NASA/NORAD algorithm of calculating near earth satellites. Any satellite with an orbital time of less than 225 minutes should use this algorithm. Satellites with orbital times greater than 225 minutes should use the SDP4 or SDP8 algorithms (Hujsak, and Hoots, 1982). The choice of 225 minutes for selecting the propagation model (near-Earth or Deep-Space) appears somewhat arbitrary, but is thought to relate to the original range of the NORAD tracking radar system.

TLE data should be used as the input for the SGP4 algorithm. The accuracy of SGP4 is typically 0.1° longitude and 0.1° latitude from the ground. TLE data older than 30 days is considerably inaccurate due to perturbations in the orbit.

The SGP4 model was developed by Ken Cranford (Lane, and Hoots, 1979). This model was obtained by simplification of the more extensive analytical theory of Lane and Cranford (1969) which uses the solution of Brouwer (1959) for its gravitational model and a power density function for its atmospheric model (Lane, Fitzpatrick, and Murphy, 1962).

For SGP4 the mean motion is first recovered from its altered form and the drag effect is obtained from the SGP4 drag term (B\*) with the pseudo-drag term being ignored.

To summarize, the SGP4 uses a geopotential model of 4th order (Perosanz, 2004):

$$V = -\frac{GM}{r} \left( 1 - \sum_{n=2}^4 J_n \left( \frac{r_e}{r} \right)^n P_n(\sin \phi) \right) \quad (\text{Equation 1})$$

To model:

Equatorial pad (J2).

Form pear (J3).

Additional deviation (J4).

It models also the atmospheric trail which slows down the satellites on their trajectory.

### 3. THE TWO LINES ELEMENTS

(Internet Université de Marseille, 2007) (Cours de télédétection, 2004)

#### NASA 2-Line Format

This is the format used by NASA to distribute satellite elements in their NASA Prediction Bulletin (Kozai, 1959; DCD, 1977).

The format consists of groups of 3 lines: One line containing the satellite's name, followed by the standard Two-Line Orbital Element Set Format identical to that used by NASA and NORAD (Hoots and Roehrich, 1988).

Data for each satellite consists of three lines in the following format:

NOAA 18

1 28654U 05018A 07011.61594517 +.00000288 +00000-0 +18419-3 0 07954

2 28654 098.8143 315.6637 0014444 354.5392 005.5612 14.11027555084775

Line 0 is a twenty-four character name.

Lines 1 and 2 are the standard Two-Line Orbital Element Set Format.

The format description is resumed in the table1:

**Table 1:** The two lines elements format description  
*Tableau 1 : Description du format des fichiers à deux lignes*

Line 1 column	Description
01	Line Number of Element Data
03-07	Satellite Number
08	Classification (U=Unclassified)
10-11	International Designator (Last two digits of launch year)
12-14	International Designator (Launch number of the year)
15-17	International Designator (Piece of the launch)
19-20	Epoch Year (Last two digits of year)
21-32	Epoch (Day of the year and fractional portion of the day)
34-43	First Time Derivative of the Mean Motion, revolutions per day
45-52	Second Time Derivative of Mean Motion (decimal point assumed)
54-61	BSTAR drag term (decimal point assumed) for GP4 perturbations (otherwise radiation pressure coefficient)
63	Ephemeris type
65-68	Element number
69	Checksum (Modulo 10)
Line 2 column	
01	Line Number of Element Data
03-07	Satellite Number
09-16	Inclination [Degrees]
18-25	Right Ascension of the Ascending Node [Degrees]
27-33	Eccentricity (decimal point assumed at beginning)
35-42	Argument of Perigee [Degrees]
44-51	Mean Anomaly [Degrees]
53-63	Mean Motion [Revs per day]
64-68	Revolution number at epoch [Revs]
69	Checksum (Modulo 10)

#### 3.1 Decoding the two lines elements

For decoding the TLE files, we have developed a software, shown in the figure 1, which extracts the following orbital elements:

Epoch : Specifies the time at which the set of orbital elements was taken (Lainey, 2002).

Orbital Inclination : the angle between the orbital and the equatorial plane

Right Ascension of Ascending Node (R.A.A.N.): An angle, in the range 0 to 360 degrees, measured at the centre of the earth, from the vernal equinox to the ascending node.

Argument of Perigee : The angle between the line-of-apsides and the line of nodes.

Eccentricity : In the Keplerian orbit model, the satellite orbit is an ellipse. Eccentricity determines the shape of the ellipse: when  $e=0$ , the ellipse is a circle. When  $e$  is very near 1, the ellipse is very long and skinny.

Mean Motion : A number which indicates the complete number of orbits a satellite makes in one day

Mean Anomaly : An angle that increases uniformly with time, starting at perigee, use to indicate where a satellite is located along its orbit.

#### 4. POSITIONNING ANTENNA CALCULATION

Disposing of the orbital parameters, it is possible now to call upon the SGP4 propagator which will provide us the position and the speed of the satellite in the ECI coordinate system.

The ECI coordinate system, shown in the figure 2, is defined as a Cartesian coordinate system, where the coordinates (position) are defined as the distance from the origin along the three orthogonal axes (Hujsak, 1979).

The z axis runs along the Earth's rotational axis pointing North,  
The x axis points in the direction of the vernal equinox,  
The y axis completes the right-handed orthogonal system.

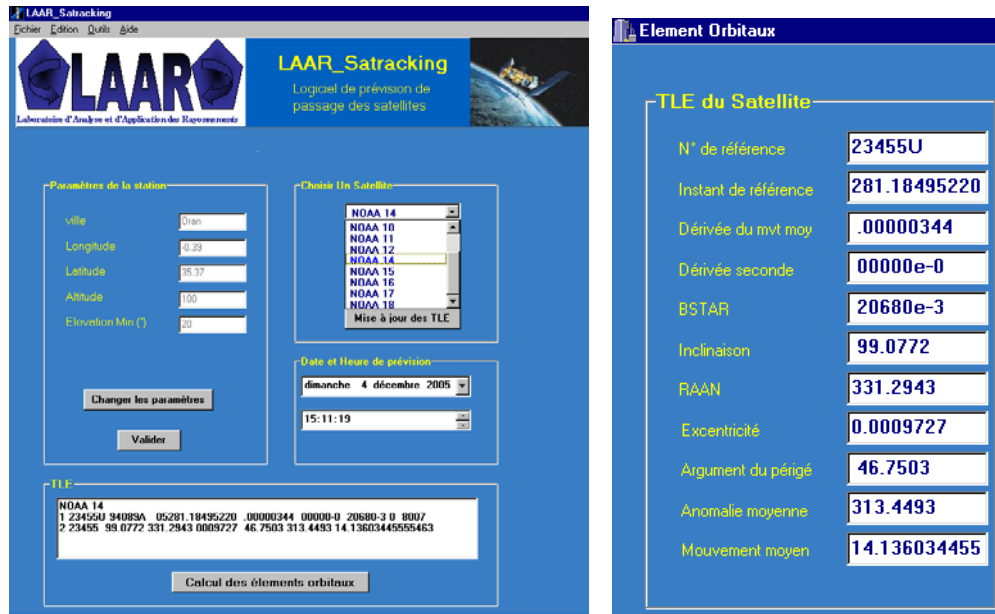

Figure1: Decoding TLE files interface  
Figure1: Interface de décodage des fichiers TLE

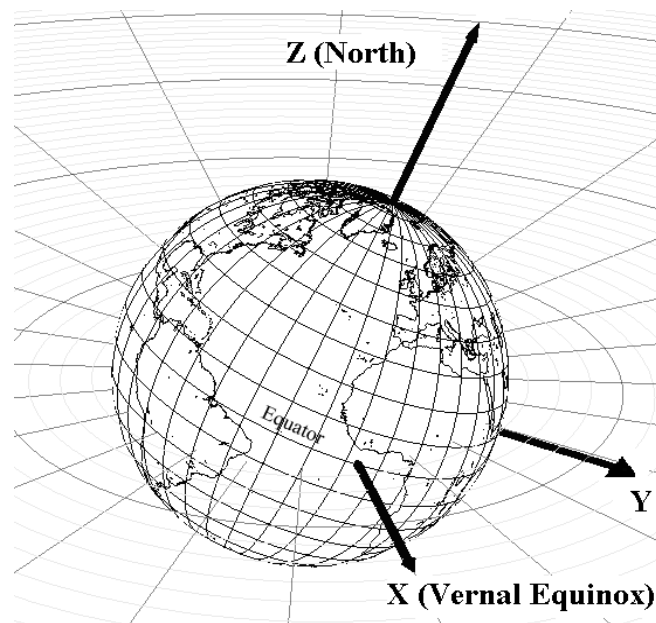

Figure2: The ECI coordinate system  
Figure2 : Le repère ECI



## 5. ALGORITHM IMPLEMENTATION

Explained in figure 4 and table 2.

**Table 2:** Interface prevision procedure  
*Tableau 2 : Différentes zones de l'interface de prevision*

1	Ground station localization (longitude, latitude and altitude)
2	Choice of the tracked satellite.
3	The two lines corresponding to the selected satellite.
4	Decoding TLE age files (Julian day + Year).
5	Extraction of the fractional part for calculating the epoch (hour, minute and second)
6	Adjustment of time prevision.
7	Choice of the prevision interval (in seconds).
8	Prevision interval (in this example: 15 seconds).
9	Azimuth that must have the antenna for pointing the satellite.
10	Elevation that must have the antenna for pointing the satellite.

## 6. DESCRIPTION OF THE TRACKING HARDWARE PART

### 6.1 Synoptic diagram of satellite tracking

The tracking can be summarized in three stages (figure 5):

- Upturn of the antenna position.
- Comparison with the values calculated by the prevision software.
- Control of the antenna.

We recover the antenna position information via the control panel of the rotor.

While comparing the antenna position with the values calculated by the prevision software, the same interface orders the rotor so that the values read on the potentiometers correspond to those calculated by the software.

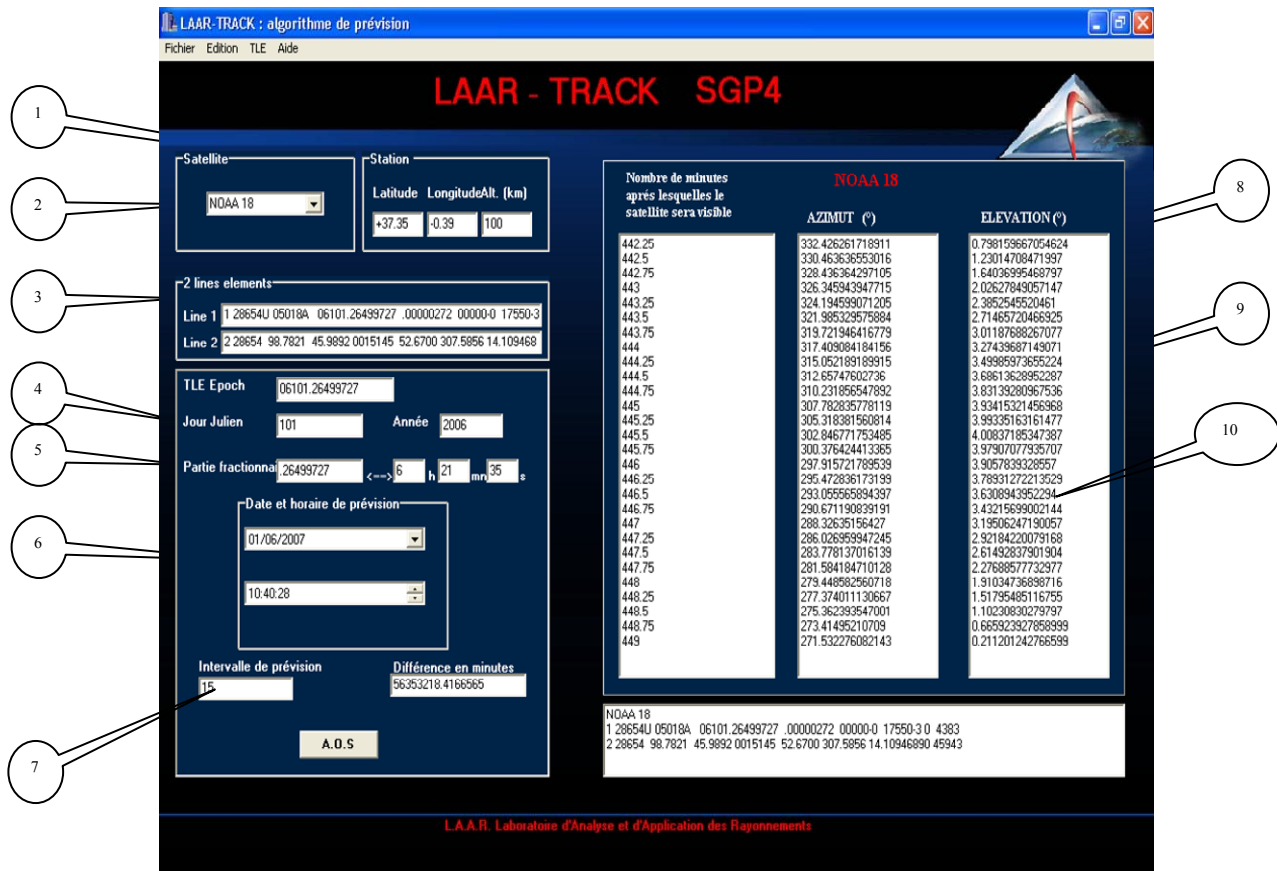

**Figure 4:** The prevision software  
*Figure 4 : Le logiciel de prevision*

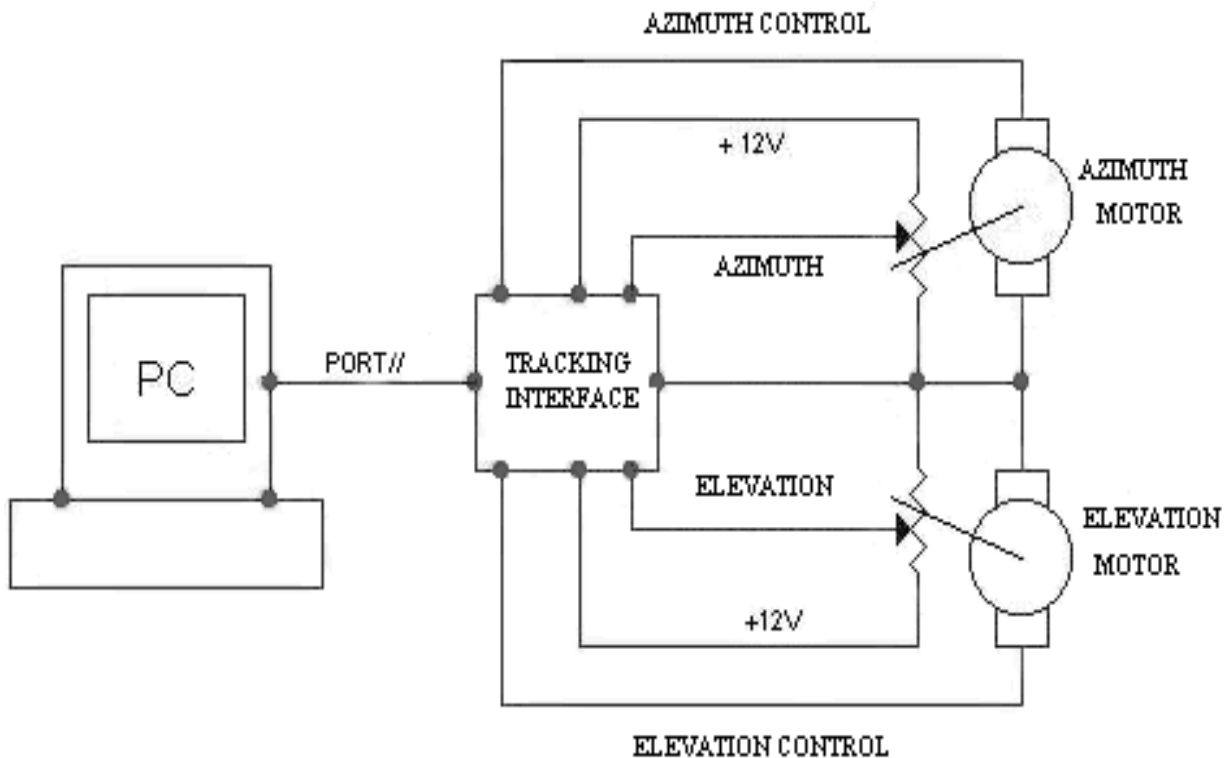

**Figure 5:** Synoptic diagram of satellite tracking  
*Figure 5 : Schéma synoptique de la poursuite automatique*

## 6.2. The interface tracking

The interface tracking guarantees the communication between the hardware part and the prevision software, by ensuring the data flow between the antenna rotor and the computer which contains the prevision algorithm.

### 6.2.1 Interface tracking implementation:

The interface, shown in the figure 6, is connected to the PC where the prevision software is installed, through the parallel port.

The antenna elevation is recovered through the pin1 of the rotor:

When the potential = 0 volt → elevation = 0°

When the potential = 5 volt → elevation = 180°

The antenna azimuth is recovered through the pin6 of the rotor:

When the potential = 0 volt → Azimuth = 0°

When the potential = 5 volt → Azimuth = 450°

These data are compared with the elevation and azimuth values generated by the prevision software, by using differential amplifiers (LM324).

Transistors (BC546) are used to amplify the control currents of motors, Azimuth (Left, Right) and elevation (Up, Down), through pins 2, 3, 4 and 5 of the DIN card located on the back face of the control panel, in such way that the difference at the exit of the differential amplifiers is null.

We have slightly modified the original design of XQ2FOD, by removing the LM358 and put instead a simple potential resistive divider (R17, R18, R19 for the comparators U3A, U3B, U3C, U3D), and a trimmer R20 to calibrate the CNA TLC7528).

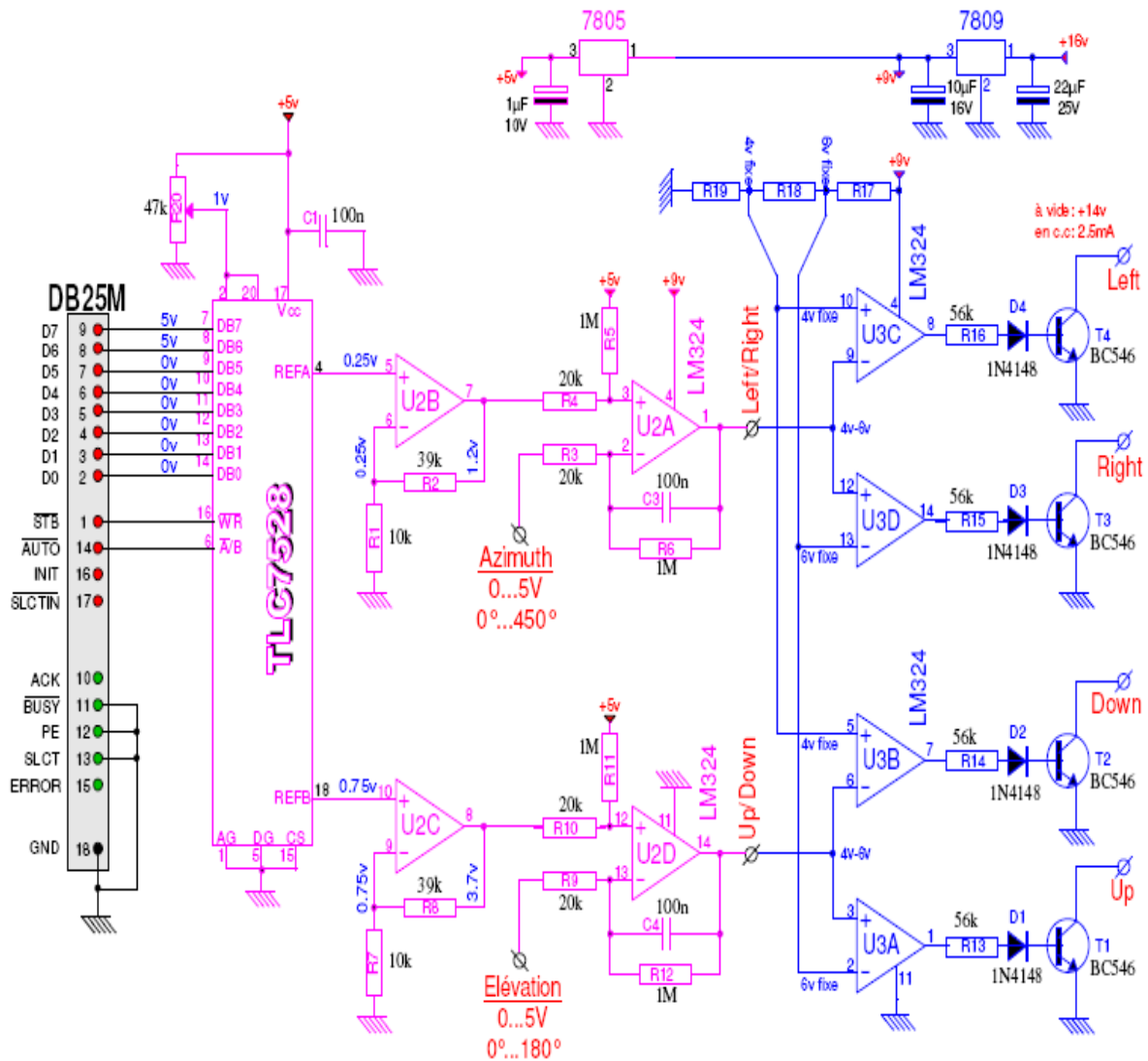

**Figure 6:** Electronic scheme of the tracking interface  
*Figure 6 : Schéma électronique de l'interface de poursuite*

## 7. RESULTS OF THE AUTOMATION

To reflect the improvement of the automation, a comparison has been made between the quality of the images received automatically and manually (Figure 7). The quality factor can take three values:

- Factor = 0: no reception
- Factor = 1: Bad reception (picture with defaults)
- Factor = 2: high-quality reception

With the manual reception, we were always faced up to cuts in the reception; which causes black horizontal lines in the received images. This was mainly due to the imprecision of the manoeuvres of the operator who was reluctant to find the best position of the antenna.

We can clearly notice that since the 01/09/2007, with the automatic reception, the NOAA HRPT images have been received with an excellent quality. However, in some rare cases (such as the 27/02/2008), there was no received signal, most of the time because of bad weather conditions.

The figure 8 shown the quality difference between the HRPT images received automatically and manually.

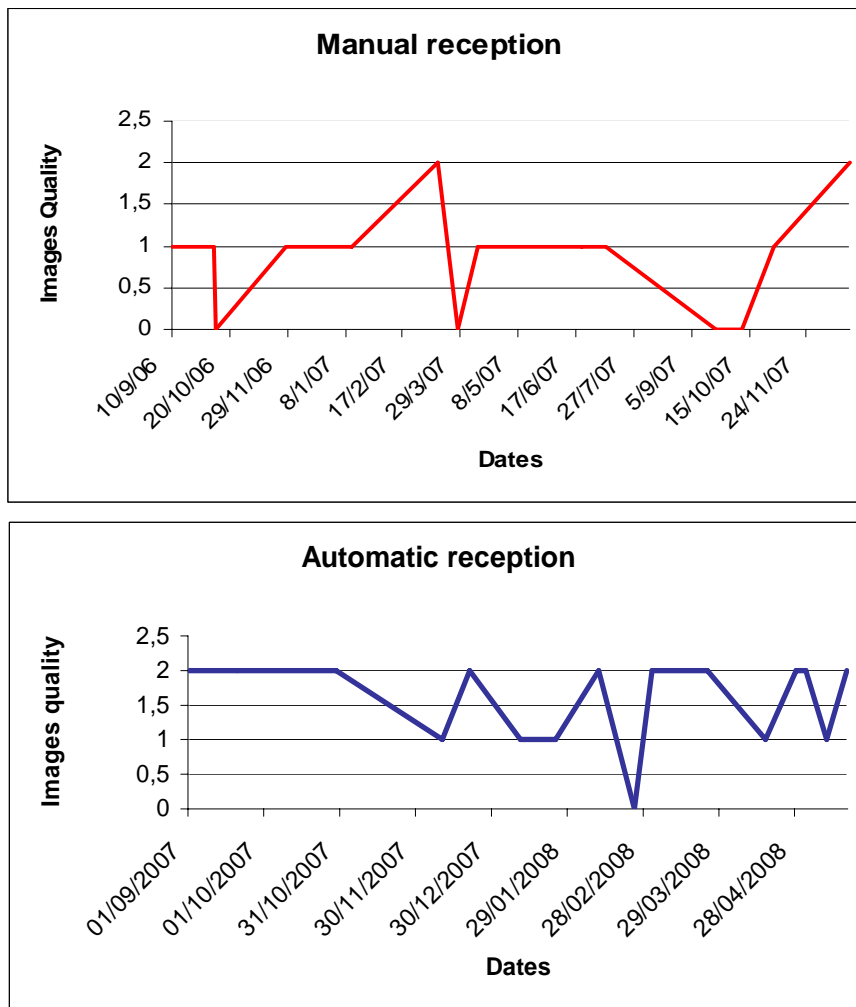

**Figure 7:** Comparison between the quality of the manual and automatic reception  
*Figure 7: Comparaison entre la qualité de la réception manuelle et automatique*

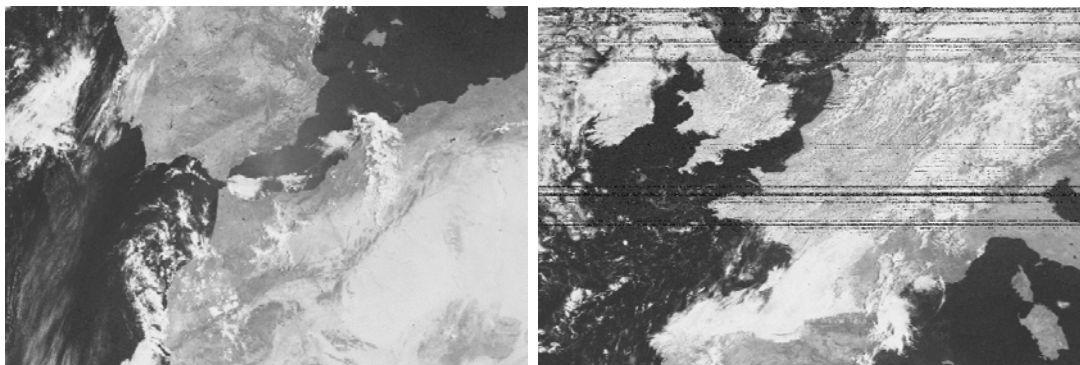

**Figure 8:** HRPT images received automatically (at left) and manually (at right)  
*Figure 8: Images HRPT reçues automatiquement (à gauche) et manuellement (à droite)*

## 8. CONCLUSION

The aim of the proposed work is to provide a tracking system for LEO satellites, composed of a software part and a hardware one.

Automatic pointing of satellite antennas helps to improve signal quality and also frees the operator to focus on the satellite contact. There are three components in an automatic pointing system; azimuth and elevation rotors, satellite track software loaded on a computer, and an interface that connects the rotors to the computer

The satellite track software, that we have developed, calculates at any time the position of the Polar Orbiting satellites and where the antennas should be pointed in space. It is based on the SGP4 model that takes into consideration the disturbing forces that constantly cause the satellite to move from its assigned position, such as gravitational attraction of the sun and the moon and the earth gravitational field.

The hardware part ensures the control of the rotor antenna (Yeasu G5500). The tracking interface reads the feedback antenna position voltages from the rotor and converts them to a digital word value that is compared with satellite position data information (calculated with the satellite track software) and send appropriate commands to move the rotors.

With the manual reception, precision pointing of the antenna was low, especially when the satellite is at the zenith of the station, because the antenna will have to move quickly to follow the satellite.

## Référence

- Brouwer, D. (1959), "Solution of the Problem of Artificial Satellite Theory without Drag", *Astronomical Journal* 64, 378—397.
- Cours de télédétection (2004) Institut National Agronomique Paris-Grignon, Département Agronomie-Environnement, UFR Dynamique Des Milieux Et Organisations Spatiales,
- DCD (1977), Defense Command Space Computational Centre Program Documentation, Section 3, 82—104.
- Hilton, C.G. and Kuhlman, J.R. (1966), "Mathematical Models for the Space Defense Center", Philco-Ford Publication No. U-3871, 17—28.
- Hoots F. R. and Roehrich R. L.(1988), "Models for Propagation of NORAD Element Sets" SPACETRACK REPORT N° 3.
- Hoots, F.R. (1980), "A Short, Efficient Analytical Satellite Theory". AIAA Paper No. 80-1659.
- Hujsak, R.S. (1979), "A Restricted Four Body Solution for Resonating Satellites with an Oblate Earth", AIAA Paper No. 79-136.
- Hujsak, R.S. and Hoots, F.R. (1982), "Deep Space Perturbations Ephemeris Generation", Aerospace Defense Command, Peterson AFB, CO.
- Kelso T. S. (1995) "Orbital Coordinate Systems", *Satellite Times Journal*.
- Kenneth Seidelmann P. (1992) "the Explanatory Supplement to the Astronomical Almanac", University Science Books - Ed Edition - Page 50
- Kozai, Y. (1959), "The Motion of a Close Earth Satellite", *Astronomical Journal* 64, 367—377.
- Lainey V. (2002) « Théorie dynamique des satellites galiléens » Thèse de doctorat présentée à l'Observatoire de Paris. Spécialité : Dynamique des systèmes gravitationnels.
- Lane, M.H. and Cranford, K.H. (1969), "An Improved Analytical Drag Theory for the Artificial Satellite Problem", AIAA Paper No. 69-925.
- Lane, M.H. and Hoots, F.R. (1979), "General Perturbations Theories Derived from the 1965 Lane Drag Theory", Project Space Track Report No. 2, Aerospace Defense Command, Peterson AFB, CO.
- Lane, M.H., Fitzpatrick, P.M., and Murphy, J.J. (1962), "On the Representation of Air Density in Satellite Deceleration Equations by Power Functions with Integral Exponents", Project Space Track Technical Report No. APGC-TDR-62-15, Air Force Systems Command, Eglin AFB, FL.
- Oja E. J.(2004) "Project Atmosphere Teacher's Guide's" Projet Atmosphère Canada – satellites météorologiques.
- Perosanz F.(2004) « Orbitographie précise de satellites en orbite basse », Journée thématique « Galileo et la science », CNES, Paris
- Site Internet (2004): <http://www.educnet.educatio.fr/orbito.htm>
- Site Internet Université de Marseille (2007): [http://artemis.univ-mrs.fr/cybermeca/formcont/mecaspa/code\\_tle/code\\_tle.htm](http://artemis.univ-mrs.fr/cybermeca/formcont/mecaspa/code_tle/code_tle.htm)