

IMPROVING LEARNING EFFICIENCY FOR DIGITAL MODULATION COURSES

Ph. DONDON- J.M MICOULEAU-P.KADIONIK
 ENSEIRB, 1 avenue A. Schweitzer- 33402 TALENCE
 FRANCE

Philippe.Dondon@enseirb.fr

Abstract : - Teaching the digital transmission techniques- like other fields of electronic- is not always easy : There is classically theoretical courses and practical lessons. The link between the two is often the most important difficulty that appears for the students. An abundant literature on digital wireless with a high level mathematical of modelling is of course available. Since a few years, theoretical courses are easily illustrated by the 2D computer simulations. But simple descriptions or analysis are rarely found and simulations do not replace a concrete true design. In order to improve the efficiency of our teaching, we present here a practical and pedagogical approach including practical electronic considerations, original and simple "Costas loop" description and design considerations for understanding and designing communication circuits. Based on the psychological Hermann brain model, this method looks like a progressive linear guide. A QPSK modulator/demodulator topology is used to illustrate our approach.

1. Introduction

Since a few years, we observed some major changes in student's behaviour in our engineer school: They are less interested in theory and "reject" all courses which have no concrete application. So, one of our challenge is how to motivate these new students generation to the fundamental courses. Moreover, even if simulations tools like SIMULINK are helpful and "funny to use", they do not fit perfectly the behaviour of a true circuit. The use of an intuitive and practical approach seems to be more efficient than traditional courses for these students. The job we present here is a try to create a didactical link between theoretical course and practical lesson. The example of a hand made QPSK modulator/demodulator is used to illustrate this approach.

2 Digital modulation backgrounds

At the beginning of the practical lesson, we first extract from the theory, the fundamental definitions of digital modulation [1]. So, the beginners can also understand the main concept of transmission even they are not familiar with the full theory. After a first practical lesson on amplitude and frequency modulation, they started the QPSK training lesson. To be as simple as possible, our experimental kit works at an intermediate frequency of 455 kHz with a maximum bit rate of 20kbits/s.

3. QPSK modulation

3.1 QPSK Modulator design

The modulator is based on the classical structure given in figure 1. [2]

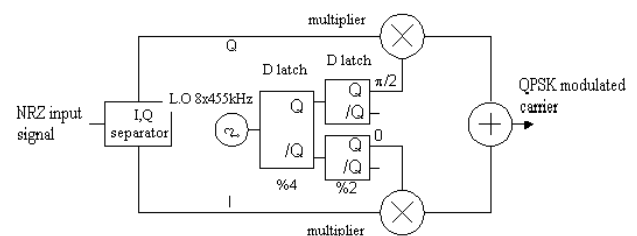

Fig 1 : QPSK modulator

Our hand made kit includes:

- A local oscillator running with a ceramic resonator at 3,64MHz, and a divider down to 455 kHz,
- A sinusoidal carrier quadrature generator with 455 kHz ceramic filter
- A Xilinx FPGA, which generates a pseudo random NRZ bit steam, with an adjustable clock rate from 10 to 20kBits/s (simulating a data flow) and separates into I,Q trains, (figure 2)
- Optional Bessel or Raised cosine integrated filters
- Two high bandwidth multipliers
- A summation high speed OP amp circuit

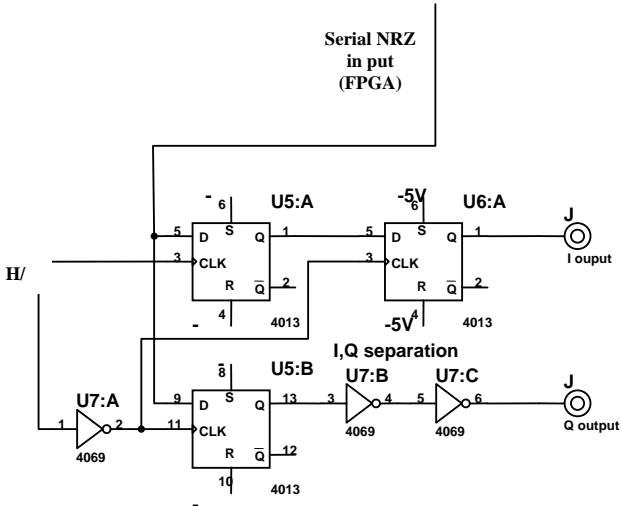

Fig 2 : I,Q data generator schematic

I and Q are generated inside the FPGA : the figure 3 illustrates the timing diagram according to figure 2 schematic: from the NRZ signal, one bit over two is switched to the I output, and one over two is switched to the Q output. The I,Q data rate is thus half of the clock rate. [6]

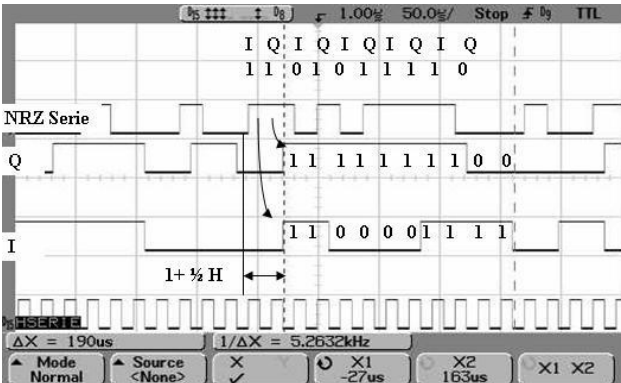

Fig 3 : I, Q separation diagram

Upper trace: NRZ incoming signal
 Middle traces: I and Q separated trains
 Lower trace: NRZ data clock

Due to the power supply circuit, I and Q are two levels bipolar signals with an average DC voltage equal to zero. So, I and Q can be symbolically represented by two level values +1 and -1.

On our kit, I and Q arms can be (or not) filtered by an improved Bessel 8th order LT 1164-7 [5] or LT1069-7 raised cosine filter (which are close enough to Gaussian filters) as indicated on block diagram in Figure 5. The figure 4 gives the theoretical response of a raised cosine filter where α is called the roll off factor.

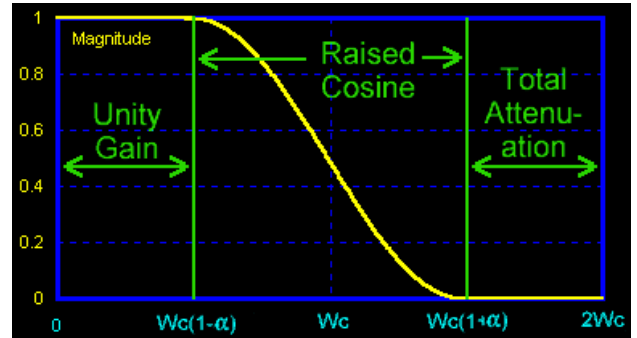

Fig 4 : Cosine raised filter response

Thus, the impact of filtering on modulated carrier spectrum and eye diagram can be easily observed (cf section 5). The I, Q data's can also be (or not) synchronised with the carrier just to make the observation of modulated signal easier.

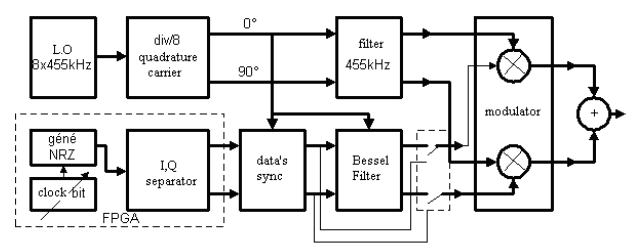

Fig 5 : modulator block diagram

3.2 QPSK Demodulator design

The demodulator is based on the classical coherent demodulator structure given in figure 6.

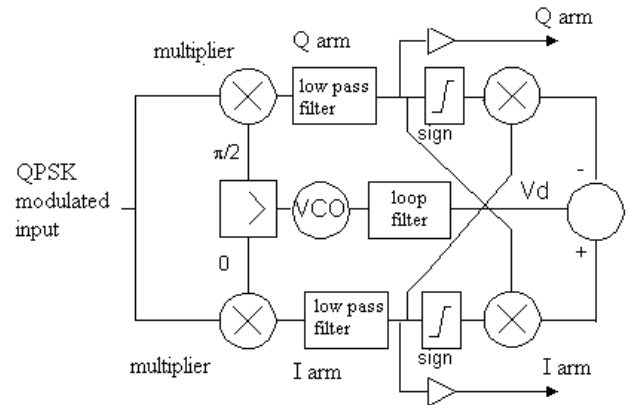

Fig 6 : QPSK Costas loop demodulator

- Our hand made demodulator kit includes:
- A voltage controlled oscillator at 4 x 455 kHz and a divider down to 455 kHz,
 - A sinusoidal carrier quadrature generator with 455 kHz ceramic filter
 - Two analogue multipliers for coherent demodulation
 - Two simple low pass filters (I, Q filtering)
 - Two fast comparators for sign detection

- Two analogue multipliers, a error OP amp circuit, and a first order loop filter for the Costas loop.

Even if the Costas loop is well known and classically used in the most digital transmission since almost 40 years, only highly strong mathematical analysis are available to understand the operating mode of this loop.

Between the too much theoretical approach and the too much simple explanations and synoptic we founded in the literature, we developed a quite simple approach to help the students in that way. The incoming signal can be written as:

$V_e(t) = I \cos \omega t + Q \sin \omega t$, where ω is the carrier frequency.

Let suppose that the local oscillator (V_{ol}) of the receiver is locked on the carrier frequency but not exactly in phase.

Thus, we can say: $V_{ol} = A \cos(\omega t + \phi)$.

To understand the impact of ϕ , we have to make a simple trigonometric calculus.

At the multiplier output of the "I arm", we obtain:

$$A \cos(\omega t + \phi) \cdot [I \cos \omega t + Q \sin \omega t]$$

After low pass filtering on the "I arm":

$$A \cdot I/2 \cdot \cos \phi - A \cdot Q/2 \cdot \sin \phi \quad (1)$$

At the multiplier output of the "Q arm", we obtain:

$$A \sin(\omega t + \phi) \cdot [I \cos \omega t + Q \sin \omega t]$$

After low pass filtering on the "Q arm":

$$-A \cdot I/2 \cdot \sin \phi + A \cdot Q/2 \cdot \cos \phi \quad (2)$$

Assuming ϕ small, and using limited development formulas, it yields:

For the I arm and from (1):

$$A/2 \cdot I (\cos \phi - Q/I \cdot \text{tg } \phi)$$

Thus:

$$A/2 \cdot I (1 - \phi^2/2 - (Q/I) \cdot \phi) \quad (3)$$

For the Q arm and from (2):

$$A/2 \cdot Q (\cos \phi + I/Q \cdot \text{tg } \phi)$$

Thus:

$$A/2 \cdot Q (1 - \phi^2/2 + I/Q \cdot \phi) \quad (4)$$

As we can see on (3) and (4), I and Q are fully well recognised if ϕ equal zero. (case of perfect coherent demodulation).

After crossed multiplication between one arm by the sign of the other, the error voltage V_d can be written as:

$$V_d = \{ \text{sign (arm I)} \times \text{arm Q} \} - \{ \text{sign (arm Q)} \times \text{arm I} \}$$

I	Q	Error voltage V_d
+1	-1	$A/2 \cdot [-I \cdot (1 + \phi - \phi^2/2) - Q \cdot (1 - \phi - \phi^2/2)]$
-1	+1	$A/2 \cdot [+I \cdot (1 + \phi - \phi^2/2) + Q \cdot (1 - \phi - \phi^2/2)]$
+1	+1	$A/2 \cdot [I \cdot (1 - \phi - \phi^2/2) - Q \cdot (1 + \phi - \phi^2/2)]$
-1	-1	$A/2 \cdot [-I \cdot (1 - \phi - \phi^2/2) + Q \cdot (1 + \phi - \phi^2/2)]$

Table 2

After replacing I and Q by there values (+1,-1) in each expression, it yields:

$$V_d = A/2 \cdot (-2 \cdot \phi) \text{ whatever the symbol value}$$

The error voltage V_d is thus always, proportional to the phase shift while ϕ remains small (between $-\pi/4$ et $+\pi/4$). In fact, we can show that $V_d = f(\phi)$ is a $\pi/2$ periodic function. The loop can be locked with a phase ambiguity of $k \cdot \pi/2$. Confusion or inversion on I and Q bits can then occur. This well known phenomenon can be visualized on our practical kit.

From this shortened analysis, we can understand some basic effects of a non zero phase shift:

- When ϕ increases, we can guess, from table 1, a change in the amplitude of I and Q : a confusion between the logical level '1' et '0' can occur.
- These changes can also be simulated using Excel or "Matlab Simulink" software, for example.
- At least, the effect of the phase shift can be observed looking at the I,Q constellation : ϕ introduces a rotation compared to the ideal position.

Then, the amplitude changes can also be interpreted by comparing the vector projection on I and Q axis. (cf figure 7)

Fig 7 : effect of phase shift

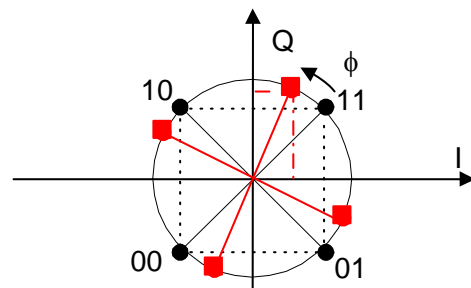

The Costas loop description is finished like a classical PLL loop with a loop filter and VCO. Replacing the feed back loop by an equivalent phase comparator, the analogue loop filter characteristics are "guessed" by the students according to VCO lock and capture range and to the equivalent phase

comparator gain: a low pass structure including an integrator cell is at least required to ensure a null phase error.

In order to characterize the loop behaviour as simply as possible, we add on our demodulator card, some extra functionalities as indicated in figure 8.

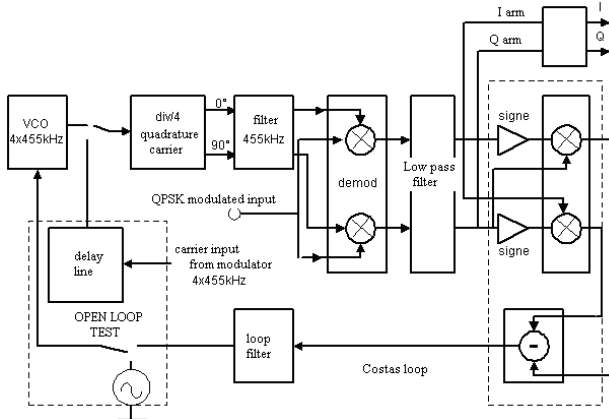

Fig 8 : demodulator block diagram

- a programmable delay line allows to enter directly the carrier reference from the modulator (instead of the local recovery carrier) and delays it, in order to obtain the transfer curve $V_d=f(\phi)$. It can also be used to observe the impact of ϕ on I and Q arms, eye and constellation diagram. (Cf section 5)
- an "open loop switch" allows to characterize the static and dynamic VCO and loop filter behaviours.

3.3 Electronic design considerations

We spontaneously designed our QPSK kit using classical discrete components instead of fully integrated ones. This allows a better understanding of the individual functionalities and a full test and characterization of each block included in the design.

4. Teaching strategy

4.1 Hermann model short description

Ned Hermann, past manager of the formation at General electric company developed a technique making it possible to easily know the cerebral preferences of an individual. This universally recognised method is intended for better including/understanding the preferences of an individual like his approach to particular problems. It results in a representation of the brain into four quadrants (figure 9) which correspond to four preferences of operation. Quadrant A (blue) shows

the preference of the individual for logic, modelling, (typical profile : mathematician, data processing specialist ...) B (green) its aptitude for the practice and planning (real time production scheduler, administrative profile...). The quadrant D (yellow) shows the preference for the risk and projection in the future (typical profile : "start-up" manager, risk manager, artist...), and C (red) for the relational one, emotion (typical profile : social and commercial workers.

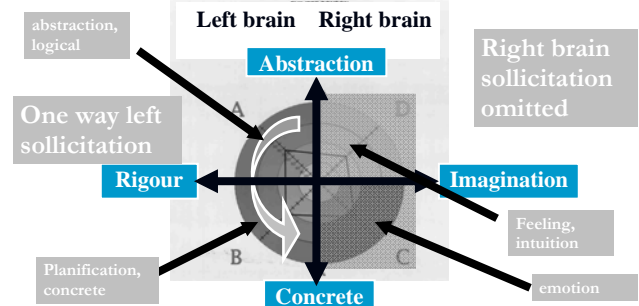

Fig. 9 : Herman brain model

We can also use the Herman model to improve the teaching approach: indeed, if one superimposes the traditional diagrams of teaching scientists (course, training, practical lesson) on the diagram, one realises that the process of training requests only the left brain, that the approach is downward (theory towards the practice or practical towards the theory). Consequently, the motivation, the emotional aspect, the need to know with what is useful received teaching, is completely ignored. This negligence partly results in reinforcing the incomprehension of the pupils, their lack of interest and their absenteeism.

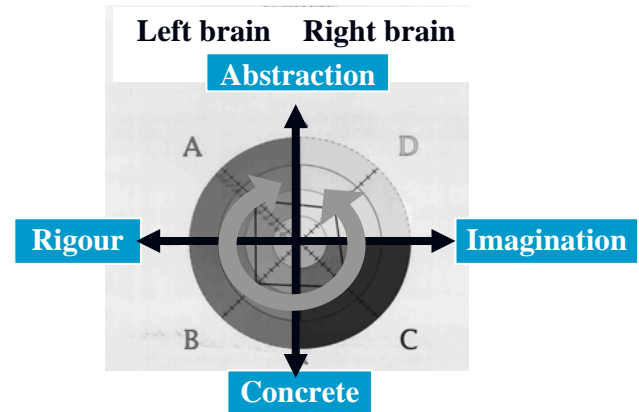

Fig. 10 : optimal use of brain capacities

According to Hermann conclusion, the best way to optimize the motivation of our students is to sweep all the quadrants starting from the right parts during an integrated lesson. (figure 10)

4.2 Applying Hermann model

As said previously, the most important for the students is to link the theory of digital modulation to a practical design as simply as possible:

The theoretical classical course on digital communications is chained with the practical training as soon as possible to maximize the efficiency of teaching.

According to the Hermann model the four quadrant of the brain model are swept, starting with the right C quadrant. And the practical lesson looks like a linear progressive tutorial guide with important “mile stones” :

a) Analysis of schematic diagram: (interactive work with the teacher) (“C” and “D” quadrant solicitation)

- Functional analysis
- Electrical analysis
- Validation of Components choices,
- Main components data sheet readings
- Effect of current and voltage static offset

of the integrated circuits,

- Signal level choices and dynamic range justification,

-Pseudo random generator analysis (clock, NRZ, I and Q signal observation (analog/digital mixed oscilloscope)

- Impact of the clock rate and of the random sequence length on the NRZ spectrum. (Oscilloscope FFT)

b) Test of the QPSK modulator : (individual student’s work) (“B” quadrant solicitation)

-Local quadrature oscillator frequency and distortion measurement (oscilloscope, time and FFT)

-QPSK modulated signal observation (time and frequency domain, spectrum analyser)

-I,Q eye diagram (constellation analyser) [5]

-Bessel and cosine filter characterization (frequency and time responses drawings)

-Effect of I,Q filtering (secondary lobe suppression, spectrum analyser)

-Effect of the bit rate on useful bandwidth (manual sweep of the data clock, spectrum analyser)

c) Test of the demodulator: (individual student’s work)

-Transfer curve $V_d=f(\phi)$ drawing (using the programmable integrated delay line, and a DC voltmeter)

-Effect of carrier phase shift on I, Q. Visualization of the constellation rotation. (Delay line and X,Y oscilloscope)

-Open loop test (lock range adjustment)

-Open loop gain transfer curve drawing

-Loop filter cut off frequency determination (graphical method)

-Closed loop test

-Constellation and eye diagram observation when locked (oscilloscope)

d) Test of modulator/demodulator (individual student’s work) (“B” quadrant solicitation)

-Phase ambiguity carrier recovery observation. (Powering on and off the power supply)

-Costas loop lock range measurement. (Manual frequency sweep of the modulator carrier)

- Frequency and phase locking ability after a cut of modulator/demodulator connection.

-I,Q demodulated stream observation

e) Results debriefing (interactive work with the teacher) (“A” quadrant solicitation)

Then, this lesson can be (or not) followed by an other one’s, much more detailed, depending on the optional courses chosen by students (in the third year school). A vector signal analyser is then used for refining and completing measurements like jitter, phase error, and other complex parameters like bit error rate.

5. Experimental

As example, we give some experimental results obtained during this practical lesson. The figure 11 shows the initial modulated signal spectrum without filtering. And figure 10 shows the effect of I,Q Bessel filtering with a cut-off frequency half of the bit rate :

- Reduction of useful bandwidth to the main lobe (secondary lobes suppression)

-Proportionality between bit rate (20 kbits/s here) and the main lobe width (20kHz). (center frequency 459kHz)

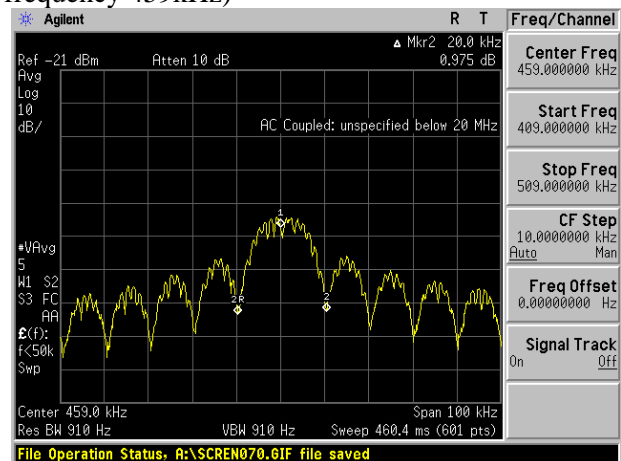

Fig 11 : Modulated carrier spectrum without I,Q filtering

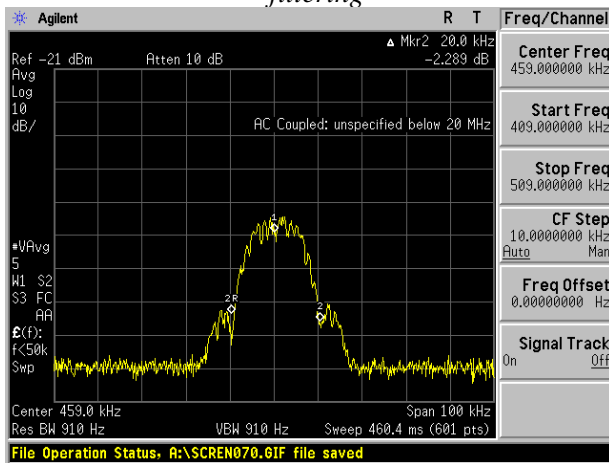

Fig 12 : modulated carrier spectrum with I,Q Bessel filtering

The figure 13 shows the constellation diagram obtained after demodulation when the costas loop is locked (Using a Tektronix oscilloscope in XY mode). The shape of the transitions between the four QPSK points depends on the I,Q filters type. Without any filter, only the four points would appear.

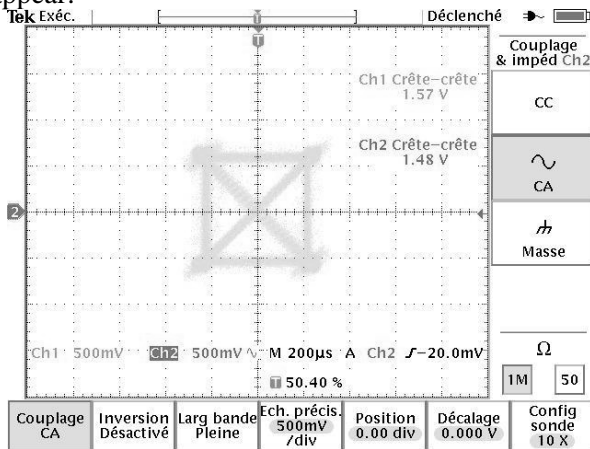

Fig 13 : QPSK constellation

The figure 14 shows the effect of a phase shift ϕ on the constellation according to the theoretical figure 7: Using the external carrier input and varying the delay time with micro switches, the constellation can be rotated up to around 45° .

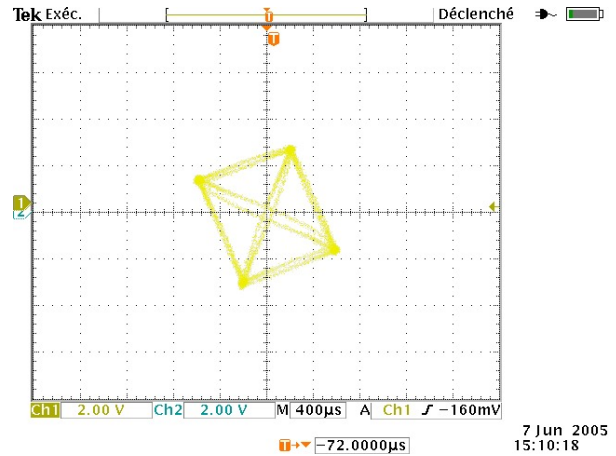

Fig 14: QPSK constellation rotation

The figure 15 shows the eye diagram in case of perfect coherent demodulation (when Costas loop locked). (Tektronix oscilloscope in “trace memory” mode). The eye’s shape and aperture depends also on the I,Q filter choice. Here, we used an improved Bessel filter with a cut-off frequency of 9,2kHz (the half of the bit rate). The thickness of the trace is due to residual signal at twice the carrier frequency (910kHz).

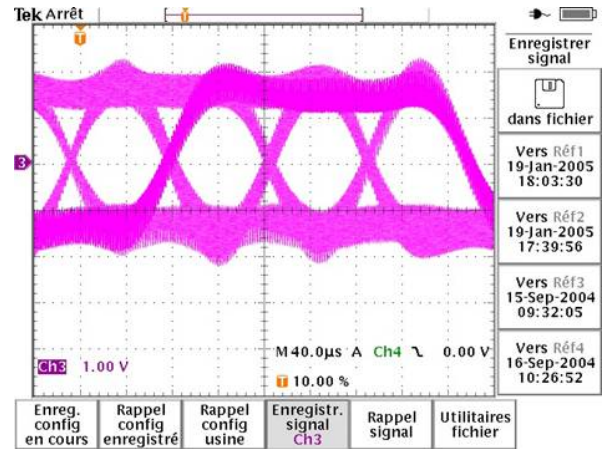

Fig 15: eye diagram

Finally, a picture of our hand made QPSK modulator/demodulator boards and test equipment is given in figure 16.

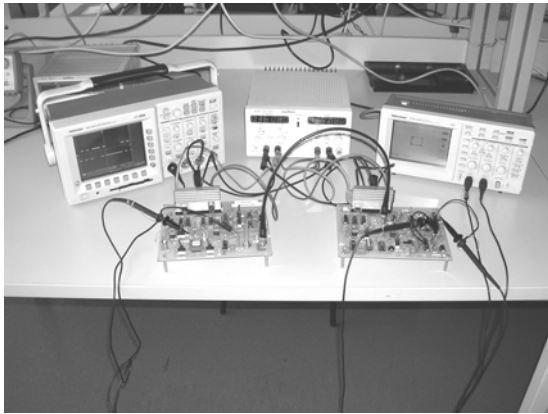

Fig 15 : QPSK test bench

[7] Hikmet Sari, *Transmissions des signaux numériques*, E-7100, vol E, Techniques de l'ingénieur, Paris

6. Conclusion

This paper is a digest of our integrated pedagogical approach. The link between theory and practical lessons has been exposed. A more detailed paper is obviously given to our engineer students. this full integrated approach is now used in our engineer school to teach the digital circuit's application and design. As we can see since a few years, the classical and conventional teaching method reached their limits. Including psychological aspects, we have shown that it is possible to improve the efficiency of our teaching.

Even if it is always difficult to “measure” the impact of a teaching strategy, this one seems to be more attractive and efficient than before, looking at the results of annual “student satisfaction report”: The last one shows that the satisfaction rate raised from 45% up to 65%. One other important point is that the students stay until they finish all the lesson even it is late: they do not leave anymore before the end, like before. This is an encouraging sign of a true motivation for this practical approach.

Of course, these first improvements will have to be obviously confirmed in the future.

References :

- [1] J. Proakis, *Digital communications, Fourth Edition*, Mc Graw Hill, 2001.
- [2] F. de Dieuleveult, *Electronique appliquée aux hautes fréquences*, éd DUNOD Paris 1999
- [3] B. Escrig, *Cours systèmes de communications numériques*, ENSEIRB 2003
- [4] *LT 1164-7 application note 56* January 1994
- [5] *Agilent Vector signal analysis basics application note 150-15*
- [6] Ph. Dondon, *Cours interne de faisceaux hertziens numériques*, T.R.T. company , 1989