

AN INTEGRATED PEDAGOGICAL APPROACH FOR A SWITCHING POWER SUPPLY DESIGN : EXAMPLE OF FLY BACK

Ph. Dondon- J.M Lequertier

ENSEIRB, 1 avenue A.Schweitzer- 33402 TALENCE-FRANCE

Abstract : Teaching the power supplies design - like other fields of electronic- is not always easy : There is classically theoretical courses and practical lessons. The link between the two is often the most important difficulty that appears for the students. Despite a abundant literature on switching power supplies, a global and simple analysis are rarely found. In order to improve the efficiency of our teaching, we present here a practical and pedagogical approach (including magnetic, practical electronic considerations, design method and flowchart) for understanding and designing classical switching power supplies. It looks like a progressive linear guide from the most simple to the most difficult. A fly back topology is used to illustrate our approach.

1. COMPONENTS BACKGROUND

1.1 Magnetics materials

The soft ferrites such as Mn-Zn or Ni-Zn are used in power electronic to make coils when the operating frequency overrides 1kHz. They are characterized by the hysteresis curve flux density vs magnetic field intensity $B=f(H)$. If an air gap is added, the effective permeability of the material decreases. It is then possible to increase the maximum available current through the coils.

1.2 Magnetics circuits

There is many available shapes E, EC, ETD, U... The choice depends on the application, power level, losses and available space. Some information are given in the data books to help the designer. The magnetic losses are also specified (in mW/cm^3) as curves or empirical formulas.

1.3 Components for energy storage

1.3.1 Simple inductances

The inductances are able to store an electrical energy as a magnetic one and then to convert it back. Using magnetic circuits as previously described allows to minimize the size of the component and to keep the magnetic flux in a small space region and thus to reduce the electromagnetic parasitic fields (EMI).

1.3.2 Transformer, coupled inductances

If we need a isolation between input and

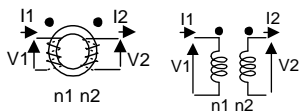

output of a power converter, a transformer [1] is obviously required.

Figure 1 : transformer symbol

$n1, n2$: number of primary and secondary turns

• : the black point indicate winding direction (here V1 and V2 have the same phase)

Two kind of components correspond to this function : transformer and coupled inductances.

a) transformer

The input power is equal in real time to the output power.

b) coupled inductances

The power transfer is done in two steps : first, the energy is stored at the primary and then transferred to the secondary. Fly back converter works like this.

These components have a basic electrical model : a serial loss inductance L_f (which corresponds to the leakage flux), a magnetization inductance L_μ (which represents the reluctance of the magnetic circuit), in parallel with an ideal transformer.

1.3.3 Magnetic saturation effect

Submitting the coil to a squared voltage can produce a magnetic saturation. (figure 2) The current can then anomalously increase till I_{Lmax} . This dangerous rising can cause damages and destruction of one or more components in the circuit.

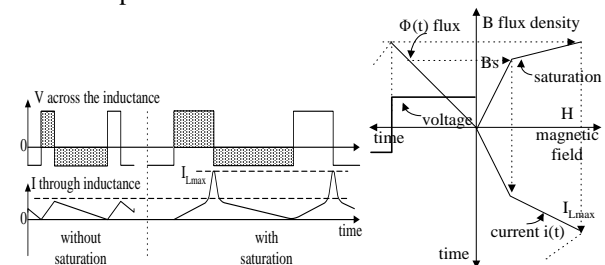

Figure 2 : effect of magnetic saturation

2. FLY BACK CONVERTER

2.1 Simplified theoretical description

The converter operates in two steps [2] :

- step 1 : the energy is stored in $L1$ (transistor "on" and diode D "off")
- step 2 : the energy is transferred to the output (D "on" transistor "off").

C_f is used to smooth the output voltage. The control of V_s is done by a feed back loop which regulate the duty cycle (on/off) on the transistor.

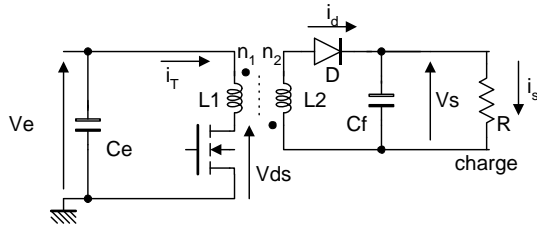

Figure 3 : simplified schematic

For a simplified description, we assume $k = n_2/n_1$ and that the switching electronic components have no losses.

2.2 Operating mode

There is two operating modes : continuous and discontinuous [2]. Only the second will be considered for our purpose. The operating mode is called discontinuous when the flux Φ inside the coil returns to zero during each cycle (cf figure 4).

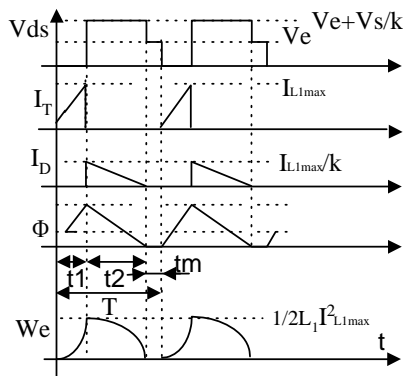

Figure 4 : discontinuous timing diagram

The most important formulas are given below :

When the transistor is on, the current I_T increases till

$$I_{L1max} = \frac{V_e}{L_1} \cdot t_1 \quad (1)$$

The diode D is turned off with a reverse voltage of $V_s + k \cdot V_e$.

The stored energy at T_1 is :

$$W_e = \frac{1}{2} \cdot L_1 \cdot I_{L1max}^2 \quad (2)$$

Assuming $t_1 = \alpha T$, it yields from (1) and (2) :

$$W_e = \frac{1}{2} \cdot V_e^2 \cdot (\alpha T)^2 / L_1 \quad (3)$$

At t_1 :

$$W_e = \frac{1}{2} \cdot L_1 \cdot I_{L1max}^2 = \frac{1}{2} L_2 I_{L2max}^2$$

with $n_2 \cdot I_{L2max} = n_1 \cdot I_{L1max}$ (4)

D turns on and the transistor becomes off. Thus :

$$V_{ds} = V_e + V_s/k. \quad (5)$$

I_d decreases with a slope of $-V_s/L_2$ till zero. The magnetic flux too. All the energy has been transferred and V_{ds} goes to the value V_e . From (3), we can obtain V_s : the input power is $P_e = W_e/T$; Assuming that there is no losses, it is integrally transmitted to the load R ; The available output power P_s is equal to P_e . As we have also $P_s = V_s^2/R$, it yields :

$$V_s = \alpha \cdot V_e \sqrt{\frac{R \cdot T}{2 \cdot L_1}} \quad (6)$$

Since $P_s = V_s \cdot I_s$, we obtain $I_s = \frac{V_e^2 \cdot \alpha^2 \cdot T}{2 \cdot L_1} \cdot \frac{1}{V_s}$ (7a)

From 7a, it comes : $L_1 = \frac{V_e^2 \cdot t_1^2}{2 \cdot P_s \cdot T}$ (7b)

At least, we give the RMS value of the primary and

secondary current : $I_{RMS} = \sqrt{\frac{1}{T} \int_0^T i^2(t) dt}$, here :

$$I_{TRMS} = \frac{I_{L1max}}{\sqrt{3}} \sqrt{\frac{t_1}{T}} \quad \text{and} \quad I_{DRMS} = \frac{I_{L1max}}{k \cdot \sqrt{3}} \sqrt{\frac{t_2}{T}} \quad (8)$$

Since the average current through L_1 is constant (cf. § II.2.4), the average voltage across the primary is null. Then :

$$t_2 \cdot V_s/k = V_e \cdot t_1 \quad (9)$$

At least, we choose for a discontinuous mode design :

$$t_1 + t_2 < 0,8 \cdot T \quad (10)$$

Similar formulas are obtained for continuous mode [3] [4].

Here, our students must well understand that :

(1) V_s depends on the load R : The converter is a power supply and not a voltage supply : a voltage regulation is required.

(2) The ratio k of the transformer determines the minimum breakdown voltage $V_{(BR)DSS}$ of the transistor because $V_{dsmax} = E + V_s/k$.

(3) As the current is greatly discontinuous, the filter capacitor C_f will be very stressed.

2.3 Output capacitor formulas

Assuming that the output current I_s is constant, the residual ripple (cf figure 5) of the output voltage ΔV_s is given by :

$$\Delta V_s = I_s \cdot \frac{t_2 + t_m}{C_f} \quad (12)$$

$$\text{with } 0 < t_m < 0,2 \cdot T \quad \text{and} \quad I_{d\text{average}} = I_s \quad (13)$$

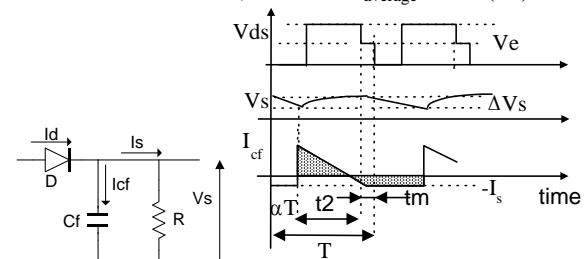

Figure 5 : timing diagram for C_f

3. DESIGN STRATEGY

The most important for the students is to link the theoretical formulas[4] to a practical design as simply as possible : a step by step design strategy is given below for the discontinuous mode.

a) Choose a MOS transistor and look at the breakdown voltage $V_{(BR)DSS}$ of the transistor. Choose the switching frequency (classically around 100kHz).

b) Assume that $V_{dmax} = 2/3.V_{(BR)DSS}$ (safety margin for voltage spikes)

c) Knowing E and V_s from specifications, calculate k from equation (5)

d) Calculate the "turn on" time t_1 from (9) and (10)

e) Knowing P_s from specifications, calculate L_1 from (7b) and L_2 from c) and e).

f) Calculate I_{L1max} from (1) then I_{L1} and I_{L2} RMS from (8) et (10)

g) From f), find the primary and secondary wires diameters. (assuming that a copper wire is able to drive around $5A/mm^2$ and taking into account the skin effect if necessary)

h) Check that the choosen transistor is well sized for the maximum current I_{L1max}

i) Choose a shottky diode (minimization of conduction losses), sized for I_{L2} RMS, the maximum current I_{L2max} , and with a reverse breakdown voltage greater than $V_s+k.E$

j) Calculate the transformer [5] :

- Choose the magnetic material and shape (it depends on the switching frequency and losses)

- Calculate the maximum energy W (in J) stored at t_1 (from(4)).

- Estimate the size and the air gap of the magnetic circuit with the manufacturer curves.

- Measure the new A_l (in nH) coefficient of the circuit with an airgap (impedancemeter measurement).

- Calculate the number of primary turns n_1 , ($L_1=A_l.n_1$) and secondary turns ($L_2=A_l.n_2$).

- Check the volume of the coils and compare to the true available volume of the core.

- Choose a bigger or smaller core size if necessary, and start again the step j)

Some commercial softwares are available to make the design of the transformer easier [3].

k) Calculate the output capacitor value from (12)

4. ENDING THE DESIGN

4.1 Voltage regulation feed back loop

As said previously, a feed back loop is required to set V_s at the nominal value. Thus, a voltage reference and a feed back loop PWM (pulse width modulation) or PFM (pulse frequency modulation) which control the duty cycle (cf. figure 6) are used. One of the difficulties in the design of the loop network is to keep the isolation between the input and the output of the converter. Thus, the feed back loop circuit must also be isolated (using an optocoupler for example). A part of the circuit must be powered by the converter output, and the other part by the input. Because of this structure, some troubleshooting could appear when starting up the converter : a particular attention must be paid to well study the "powering on" of the converter.

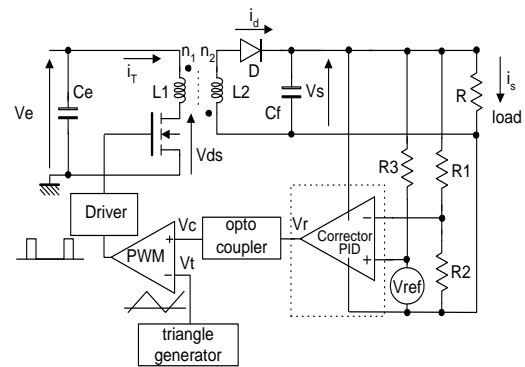

Figure 6 : feed back loop principle

In our schematic, we use a simple PWM circuit based on the comparison of a triangular waveform with the returned voltage V_c . When the system is locked, we have :

$$V_s = \frac{R_1 + R_2}{R_2} V_{ref}$$

The stability must be of course studied. However, a converter is a non linear system : its behavior depends on the operating, the bias point and the external load R . An open loop model must be first extracted.

4.2 Open loop model (discontinuous mode)

The open loop characteristics can be obtained from measurements. Mostly, the transfer function V_s/V_c looks like a low pass first or 2nd order filter (depending on the operating mode) with a cutoff frequency of a few ten Hz.. From this measurement, some dedicated test equipement are able to automatically compute a loop correction circuit. If you don't have, you can obtain manually a set of curves, varying the load resistance. Then, looking at the worst case will give the parameters for an analog correction circuit. Usually, a proportional, differential, integral correction is required to optimize the performances of the loop.

4.3 Start up and protection

Since the start up of a converter may cause destructive dammages, our students must be conscious of the aim of protection circuits :

a) soft start circuit : It allows the output voltage to reach its final value without any dangerous overshoot when the converter in turned on. Be carefull, the soft start circuit requires a capacitor which could introduce a time constant and potential unstability in the feed back loop.

b) current protection : a current sensor protects the transistor against over current.

c) undervoltage input protection : Well known as "UnderVoltage LockOut" (UVLO), it forces "off" the transistor if the input voltage goes anormally down. An automatic restart of the converter is done using the soft start sequence.

d) burst mode : When no load is connected to the converter output, no energy transfer is theoretically required. Only, the losses in C_f and the feed back network must be compensated : thus, the transistor is turned on from time to time without respecting the switching clock timing.

4.4 Snubber

Due to the stray capacitances in the circuits, spikes and oscillations occurs at the switching time. (figure 7). They generates losses and stresses for electronic components.

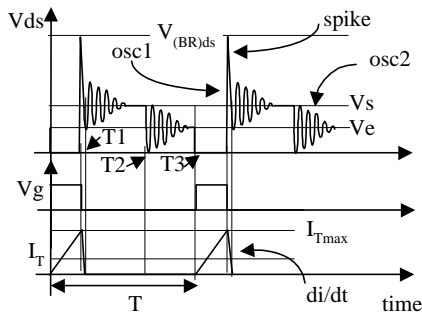

Figure 7 : parasitic oscillations

At T1, the energy is stored at the primary and transferred to the secondary. But some energy stay in the loss inductor L_f . Its dissipation produces a voltage spike on the drain which can reach the breakdown voltage of the transistor. This spike can be reduced by a very careful manufacturing of the transformer.

The oscillation can be reduced by adding a classical R,C snubber circuit in parallel with L_1 :

- the nominal voltage of the capacitor must be greater than the spike (here $\approx 150V$)
- R must be *non inductive* and sized to dissipate the power losses (Be careful, R can dissipate a few watts).

Sometimes, it could be cheaper to choose an oversized transistor to avoid the use of snubbers.

5. EXPERIMENTAL

Most of the characteristics can be measured by the students in order to compare the experimental results to the theory. For example, the figure 8 shows the effect of a snubber and oscillations reduction on our 50W flyback converter. Upper trace : drain source voltage with snubber, 50V/div; medium trace : without snubber, 50V/div; bottom trace PWM signal 20V/div; (measured with a Tek TDS220 oscilloscope)

The figure 9 shows the open loop gain response V_s/V_c without correction. As predicted, it is a first order lowpass response. Gain and cutoff frequency (around 20Hz) depend on the load R.

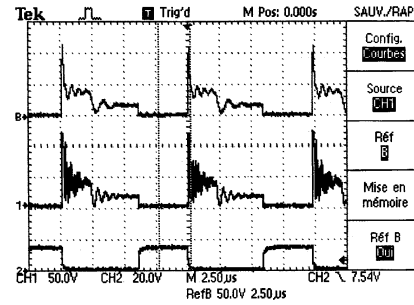

Figure 8 : snubber effect

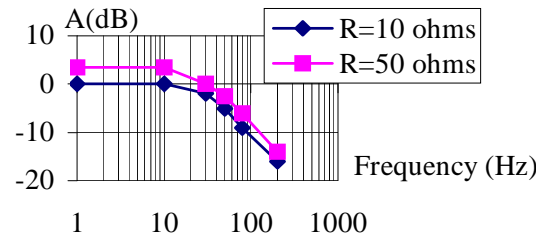

Figure 9 : open loop gain V_s/V_c

6. PEDAGOGICAL CONSIDERATION

During a practical lesson, our students first compute the main components using the design strategy. Then, they start the measurements with a simple converter circuit in order to observe the differences between the basic theory and the practical measurements. They try to point out and separate each problem we have seen in §4. Finally they understand how to reduce or to suppress it, by plugging additive components on the basic experimental structure.

7. CONCLUSION

This paper is a digest of our integrated pedagogical approach. The link between theory and practical lessons has been exposed. A more detailed paper is obviously given to our engineer students. This full integrated approach is now used in our engineer school to teach the switching power supply topologies and seems to be very attractive for the students.

REFERENCE

- [1] Techniques de l'ingénieur D 3 163, E 2 130
- [2] Alimentation à découpage, convertisseur à résonance J.P Ferrieux, F Forest ed. MASSON
- [3] Magnetic Designer user's manual from Intusoft
- [4] Switching power supply design Abraham, I.Pressman ed. Mc Graw hill
- [5] Magnetic core selection for transformers and inductors. A user's guide to practice and specification Colonel Wm T Mc Lyman ed M Dekker inc 1997