

EFFICIENT FPGA IMPLEMENTATION OF GAUSSIAN NOISE GENERATOR FOR COMMUNICATION CHANNEL EMULATION

Jean-Luc Danger⁽¹⁾, Adel Ghazel⁽²⁾, Emmanuel Boutillon⁽³⁾, Hédi Laamari⁽²⁾

⁽¹⁾Ecole Nationale Supérieure des Télécommunications, ComElec, 46 rue Barrault, 75634 Paris Cedex 13, France

⁽²⁾UTIC - Ecole Supérieure des Communications, Rte de Raoued km 3.5 – 2083 El Ghazala –Tunisia

⁽³⁾LESTER, University of Bretagne Sud, 56321 Lorient Cedex, France

danger@enst.fr, adel.ghazel@supcom.rnu.tn, emmanuel.boutillon@univ-ubs.fr

Abstract: *In this paper, a high accuracy gaussian noise generator emulator is defined and optimized for hardware implementation on FPGA. The proposed emulator is based on the Box-Muller method implemented by using ROMs tabulation and a random memory access. By means of accumulations, the central limit method is applied to the Box-Muller output gaussian distribution. After presenting the algorithmic method this paper analyzes its efficiency for different noise signal formats. Then the architecture to fit into FPGA is explained. Finally results from the FPGA synthesis are given to show the value of this method for FPGA implementation.*

- a flat spectrum;
- high sample rate (> 10 MHz.).

A theoretical method to fit this requirement was proposed by the author in [5]. This paper focuses on the FPGA implementation (namely the FLEX10K or APEX20K of Altera [2]) of the AWGN generator in order to reproduce the architecture. The paper is organized as follows : Section 2 recalls briefly the method proposed in [5], Section 3 described the overall architecture of the AWGN generator, Section 4 shows the LFSR (Linear Feedback Shift Register) optimization and Section 5 gives the design results.

1 Introduction

Fast prototyping of digital communication systems needs efficient tools for the evaluation of the performance of the transmission algorithms. For example, to obtain an estimation of the Bit Error Rate of $10^{-6} \pm 3.3\%$, 10^9 iterations have to be done. Since the number of parameters in a modern system can be very high (sampling frequency, digital format, carrier resolution, rounding and quantification,...), the search for an optimal compromise between performance and complexity is not trivial and, simulation is generally the last tool used to perform this task [4]. To avoid software delays inherent in a long simulation, hardware emulation is investigated in the research project carried out between ENST-Paris (France), SUP'COM (Tunisia), LESTER (France) and University of Toronto (Canada). The idea is to use an FPGA board to emulate the system. A synthesized model of the channel and a synthesized version of the algorithms is used to perform measurement performance at very high speed. The main difficulty in emulating the channel, is to have an accurate Additive White Gaussian Noise (AWGN) generator, i.e.:

- B bits (2 to 10) of resolution after the decimal point
- a normal distribution up to more than 4 times the standard deviation σ with a relative error less than 0.1% compared to the ideal distribution;
- a periodicity greater than 10^{18} (or 2^{60});

2. Design of accurate AWGN reference model

The Gaussian noise sample is generated in two steps. First, a quantized version of the Box-Muller method is performed to obtain a good approximation of the Gaussian distribution. Second, several samples thus obtained are accumulated to generate the final sample. The aims of this last step is to smooth the fluctuation of the distribution obtained with the quantized Box_Muller method (central limit theorem).

2.1. Box-Muller method

The Box_Muller method is widely used in software simulation. It generates a random sample n of gaussian variable $N(0,1)$ (zero mean and standard deviation $\sigma=1$) from two uniformly distributed over $[0,1]$ random variable x_1 and x_2 using (see [3] for a proof) :

$$f(x_1) = \sqrt{-\ln(x_1)} \quad (1)$$

$$g(x_2) = \sqrt{2} \cos(2\pi x_2) \quad (2)$$

$$n = f(x_1)g(x_2) \quad (3)$$

A quantized version of (1) and (2) using pre-computed values is proposed in [5]. It is based on a non-uniform quantization of segment $[0,1]$ that allows very small values of x_1 . to be reached. The non-uniform

quantization is obtained by a recursive partition of segment $[0,1]$. Segment $[0,1]$ is first partitionned in 16 sub-segments of same length, than the first sub-segment $[0,1/16]$ is then subdivided again into 16 sub-segments and so on¹. This operation is performed K times. K 16-words ROM are used to store the quantized values of $f(x)$ over each level of the partition using:

$$F_r(s) = R\left[2^m f\left(\frac{s + \delta}{16^r}\right)\right] \text{ and } F_r(0) = 0 \quad (4)$$

where r varies between 1 and K (level of partition), s varies between 1 and 15 (sub-segment number) and δ a real number between 0 and 1, gives the sample position in the segment. $F_r(s)$ is coded on $2+m$ bits, 2 for the integer part to get to $\sigma=4$, m for the fractional part. $R[x]$ denotes the largest integer lower than x . The variable x_1 is obtained using K 4-bit random generator rg_r , $r=1..K$.

The $g(x)$ quantization is simplified using the symetries of the cosine function, the segment $[0,1/4]$ is sub-divided into 256 sub-segments. Let us define s' , an 8 bit random variable. $g(x)$ is quantized as :

$$G(s') = R\left[2^{m'} \sqrt{2} \cos\left(\frac{\pi(s' + \delta')}{512}\right)\right] \quad (5)$$

where δ' and m' have the same meaning as that of δ and m of equation (5). $G(s)$ is coded on $1+m'$ bits, 1 bit for the integer part in order to get to $\sqrt{2}$, m' bit for the fractional part. From the product:

$$P(r,s,s') = R[F_r(s) \times G(s') \times 2^{B-m-m'}] \quad (6)$$

The sign of the output sample n is obtained by using a random variable $sign$ which complements $P(r,s,s')$ when equal to 1 :

$$n = (1-2 \times sign) \times P(r,s,s') - sign \quad (7)$$

2.2. Mixed method

The curve a of figure 1 compares the distribution BM_1 obtained with the parameters of Table 1 and the normal distribution $N(0,1)$ using the relative error $\xi_X(x)$:

$$\xi_X(x) = \frac{X(x) - N(0,1)(\xi)}{N(0,1)(\xi)} \quad (8)$$

B	K	m	δ	m'	δ'
6	5	7	0.467	7	0.5

Table 1: Characteristics of the Box-Muller AWGN

To smooth the large variation of the distribution BM_1 , a number A of independant Box-Muller variables are

accumulated (central limit theorem) to generate a single sample. The resulting distributions BM_2 and BM_4 obtained for $A = 2$ and 4 are shown in figure 1.

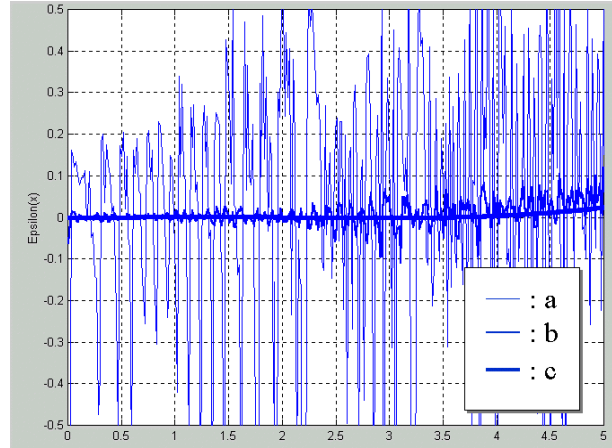

Figure 1: $\xi_X(x)$ for $X = BM_1(a)$, $BM_2(b)$ and $BM_4(c)$

Result of figure 1 shows that BM_4 (curve c) fullfilled our initial requirement.

3. Overall architecture

As shown in figure 1, good results are obtained with $K=5$ and $m=7$, which means that $(2+m)*K=45$ logic cells are needed for the F_r ROMs. A 256-byte on-chip RAM can be used for the G ROM ($m'=8-1=7$). All these parameters correspond to Table 1 above. They are a good trade-off between performance and FPGA complexity.

Once the Box-Muller variable is generated a truncation can be done according to the needed accuracy to keep only B bits after the decimal point. In our example we truncated to get 6 bits after the decimal point. When the sign bit is one, the one's complement is used to get negative values. Hence the mean value is now -2^{-B-1} instead of 0 before accumulation. After accumulation the mean and standard deviation are given by :

$$\text{mean}(BM_{A,B}) = -A 2^{-B-1} \quad (9)$$

$$\text{standard deviation}(BM_{A,B}) = \sqrt{A}. \quad (10)$$

To be as close as possible to $N(0,1)$, a compensation has to be done at the back end stage. The back end stage consists in multiplying the noise according to the needed SNR and in adding the result to the signal. For instance if $A=4$, a mere left shift of the decimal point is enough to compensate σ and the addition with -2^{-B+1} compensates the mean.

Figure 2 represents the FPGA architecture with the 3 different blocks : the set of LFSRs to generate rg_r , the F_r , G and $sign$ functions for the Box_Muller variable and the accumulator for the central limit theorem.

¹Division in 16 sub-segments is done in order to optimized the design: the number of words in a Logical CELL (LCELL) is also 16 for a FLEX10K or APEX20K FPGA circuit.

The rg_r generates the F_r ROM addresses. The address from rg_r is forced to 0 if one of the address from rg_l to rg_{r-1} is different from 0. As the $F_r(0)=0$ (see equation 4), this permits the use of an OR gate at the ROM output.

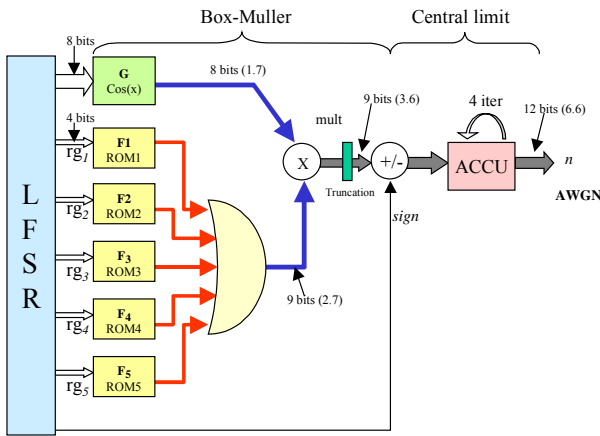

Figure 2: Architecture in FPGA

4. LFSRs optimisation

With this architecture, 29 uniformly distributed variables are necessary to generate the address bits of the 5 ROMs F_r (4 bits each), the ROM G (8 bits) and $sign$.

The use of LFSR is the classical technique to generate pseudo-random variables by using an irreducible polynomial [1]. Figure 3 illustrates the LFSR structure called "one to many" with the polynomial $x^5 + x^2 + 1$

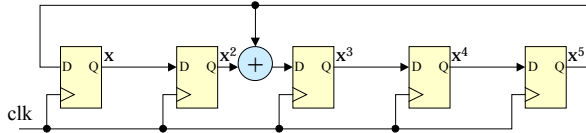

Figure 3: LFSR for $x^5 + x^2 + 1$

The period and the number of combinations is $2^n - 1$ if the LFSR has n registers. After Reset the LFSR has to be initialized with a value different from "00000" otherwise it stays in this state. Instead of using 29 LFSRs for the 29 variables, the number of LFSRs can be reduced if the address bits are grouped by packet of 4, necessitating only 7 LFSRs, 2 for the G ROM, one for each F_r ROM and one for the $sign$. At every clock cycle, 4 bits are use as outputs and "shifted". For instance for the LFSR of figure 5, t being the clock period, the register x^5 can be expressed as $x^5(t) = x^4(t-1) = x^2(t-3) + x^5(t-3) = x(t-4) + x^4(t-4)$. By considering operations every $4t$, 4 virtual shift operations are done in one clock cycle.

This technique can be easily coded in VHDL and generates almost no extra FPGA logic cells. The code of the LFSR function generator is given in the Annex for any number of outputs (parameter nb_iter in the code). Figure 4 illustrates the structure LFSR with polynomial $x^5 + x^2 + 1$ and 4 outputs.

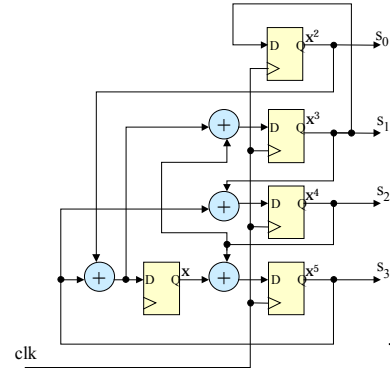

Figure 4: LFSR for $x^5 + x^2 + 1$ and 4 outputs

t	LFSR 1 output					LFSR 4 outputs				
	x	x ²	x ³	x ⁴	x ⁵	x	x ²	x ³	x ⁴	x ⁵
0	1	0	0	0	0	1	0	0	0	0
1	0	1	0	0	0	0	0	0	0	1
2	0	0	1	0	0	1	0	1	1	0
3	0	0	0	1	0	0	1	1	1	0
4	0	0	0	0	1	1	1	0	1	1
5	1	0	1	0	0	0	0	1	1	0
6	0	1	0	1	0	0	1	1	1	1
7	0	0	1	0	1	0	1	1	0	1
8	1	0	1	1	0	0	1	0	0	0
9	0	1	0	1	1	1	0	1	0	0
10	1	0	0	0	1	0	1	0	1	1
11	1	1	1	0	0	0	0	1	1	1
12	0	1	1	1	0	1	1	0	0	1

Table 2: LFSR sequences

The sequence of the first 12 combinations of LFSRs of figure 3 and 4 is indicated in Table 2. The initial value is set to "00001". This table shows combinations of the 4-outputs LFSR correspond to every fourth combination of the 1-output LFSR.

In order to meet the periodicity constraint which is greater than 10^{18} (or 2^{60}), at least a total of 60 registers of LFSRs are needed. In order to keep the highest period, the LFSRs need to have periods prime between them. To meet this condition, we propose to select the LFSR's length from the "Mersenne" numbers (number so that 2^{d-1} is a prime number).

5. Results

5.1 Accuracy

By considering the parameters of Table 1 and x between 0 and 4σ , the maximum relative error $\xi \chi(x)$ between the ideal gaussian distribution $N[0,1]$ and the synthesized one is calculated by using the MATLAB model. The accuracy depends on B , which is the number of bits after the decimal point resulting from the truncation operation, and the number of accumulations A . Table 3 represents the maximum relative error expressed in 10^{-3} for different values of A and B . For every value of B the optimal value of δ is indicated.

Max $\xi_{\chi(x)} * 10^{-3}$ between 0 and 4σ		A			
		2	3	4	5
B	1 $\delta=0.44$	0.65	0.08	0.15	0.29
	2 $\delta=0.453$	11.5	1.96	0.93	0.43
	3 $\delta=0.445$	20.2	2.12	0.56	0.34
	4 $\delta=0.467$	64.6	5.4	0.71	0.31
	5 $\delta=0.467$	57.3	5.4	1.12	0.69
	6 $\delta=0.467$	71.9	5.8	1.38	0.93
	7 $\delta=0.467$	237	8.4	0.68	0.28
	8 $\delta=0.467$	503	26.5	1.76	0.26

Table 3 : maximum relative error for different A and B

5.2 Synthesis

Table 4 gives the results obtained with the parameters of Table 1, $A=4$, $B=6$ and LFSRs of length 22,21,20,17,13,7,5,15 registers for respectively G, Fr and sign :

FPGA device	cells	mem block	clock rate	Output rate
10K100ARC240-1	434	1	74MHz	18.5MHz
10K100EQC240-1	437	0.5	98MHz	24.5MHz

Table 4 : synthesis result

The synthesis has been done using FPGA ExpressTM and MAX+PLUSIITM. The number of cells of the LFSR part is 149. In order not to lose the performance level due to the 4 accumulations, 4 Box Muller generators can be placed in parallel and added in one shot. Consequently the hardware size is multiplied by 4. Figure 5 illustrates the relative error obtained with 10^9 samples.

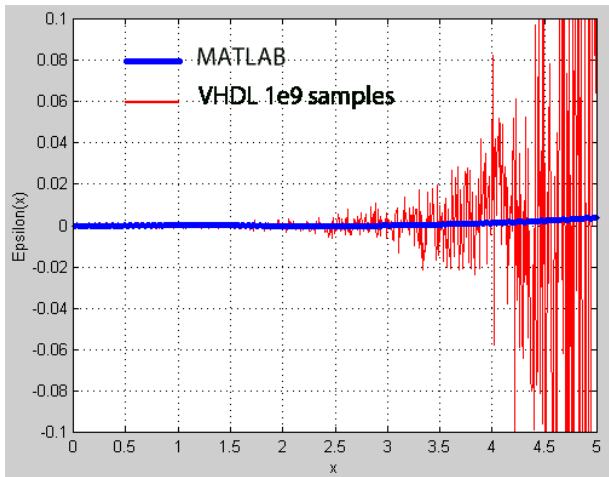

Figure 5: relative error with 10^9 samples

The difference between the theoretical distribution and the one obtained is due to the low number of samples obtained for high value of α . When the number of samples increases the distribution converges towards the result of the MATLAB simulation.

6. Conclusion

In this paper, a new technique for generating in real time gaussian noise and emulating a transmission channel was developed by applying the central limit theorem to a gaussian distribution generated by the Box-Muller method. Hardware in FPGA has been optimized by taking advantage of the logic cell structure and the on-chip RAM blocks. The proposed implementation delivers a quasi-perfect gaussian noise which has a maximum relative error of 0.1% at 4σ , compared to the ideal distribution. The FPGA hardware uses only 8% of a 100K gates FPGA and can deliver a gaussian noise at 20MHz with a period which can last a few days at this frequency.

Reference

- [1] J.G. Proakis, "Digital communications", Mc GRAW-HILL International Editions, Electrical Engineering Series, 1998.
- [2] ALTERA Data Book 1998
- [3] Donald E. Knuth, "The Art of computer programming", ADDISON-WESLEY, 1998
- [4] J.R. Ball, "A real time fading simulator for mobile radio", *The radio and Electronic Engineer*, Vol 52, N°10, October 1982
- [5] A. Ghazel, E. Boutillon, J-L Danger, G. Gulak, H. Laamari, "Design and Performance Analysis of High speed AWGN Communication Channel Emulator", Paper submitted to ICC2001, Tampere Finland

Annex

```

FUNCTION gen_lfsr(
    pol    : std_logic_vector;
    en     : std_logic;
    nb_iter : natural
) RETURN std_logic_vector IS
    VARIABLE pol_int : std_logic_vector(pol'length-1 DOWNT0 0);
    VARIABLE pol_gen : std_logic_vector(pol'length-1 DOWNT0 0);

    BEGIN
        CASE pol'length is
            when 22 => pol_gen := "0000000000000000000011";
            when 21 => pol_gen := "0000000000000000000101";
            when 20 => pol_gen := "000000000000000001001";
            when 17 => pol_gen := "00000000000001001";
            when 13 => pol_gen := "000000011011";
            when 7  => pol_gen := "0000011";
            when 5  => pol_gen := "00101";      -- x^5 + x^2 + 1
            when 4  => pol_gen := "0011";       -- x^4 + x + 1
            when 3  => pol_gen := "011";        -- x^3 + x + 1
            when others => pol_gen := "11";     -- x^2 + x + 1
        END CASE;

        pol_int := pol;

        iteration : FOR i in 1 to nb_iter LOOP
            IF en = '1' THEN
                IF pol_int(pol'length-1)='1' THEN
                    pol_int := (pol_int(pol'length-2 DOWNT0 0)&'0') xor
                    pol_gen;
                ELSE
                    pol_int := (pol_int(pol'length-2 DOWNT0 0)&'0');
                END IF;
            ELSE
                pol_int := pol_int;
            END IF;
        END LOOP;

        RETURN (pol_int);
    END gen_lfsr;

```