

A MULTI AGENT CONTROLLER FOR A MOBILE ARM MANIPULATOR

Sébastien Delarue, Philippe Hoppenot, Etienne Colle

IBISC, CNRS FRE 2873 - University of Evry, 40 rue du Pelvoux 91020 Evry cedex

sebastien.delarue@ibisc.univ-evry.fr, philippe.hoppenot@ibisc.univ-evry.fr, etienne.colle@ibisc.univ-evry.fr

Keywords: Multi-agent, arm manipulator, mobile platform

Abstract: In the assistive robotics domain, and especially for disable people, the use of mobile arm manipulator can be of a great help in the everyday life tasks. First, these systems must be reliable and fault tolerant. Secondly they must facilitate man machine co-operation. This article exposes a method based on multi agent system. This kind of distributed architecture makes possible to be fault-tolerant without any specific fault management, and thus to improve reliability. It is also possible to add specific constraints, for example human like behaviors in order to facilitate the use of the system by the operator. Moreover, this method is easy to implement.

1. INTRODUCTION

ARPH project (French acronym for Robotic Assistance to disabled People), developed in IBISC laboratory, deals with restoring handling function for handicapped person. It is a semi autonomous mobile manipulator arm. Three kinds of command mode are developed. In automatic one, the operator only gives the goal and the system achieves it automatically. It is difficult to realise and the disabled people want to act by himself/herself. In manual mode, the operator commands all the degrees of freedom of the system. This is hard task for the operator. The idea is to develop shared modes in which the operator and the system share the command. Research project is following two axes: robotics and human machine co-operation. The paper focuses on robot control while keeping in mind specificities due to the co-operation between human and machine. For example industrial robot performances such as accuracy are less necessary than easiness of control by the user and fault tolerance, the person being strongly tributary of the assistance.

The general method to control a manipulator arm is to compute mathematical static and/or dynamic models of the robot (Yoshikawa, 1990). The approach gives adequate results in known environment and for repetitive tasks. If the objective is known in Cartesian space ($p(x, y, z)^T$), those

models provide speed or angular value of arm joints so that end effector performs the task. Generally models are computed off-line so they are fixed and cannot be adapted easily to rapid changes of robot structure due to e.g. the dysfunction of one arm manipulator joint. It requires addition of specific models for making the system tolerant to fault and the management of the model change. In assistive robotics, it's an important criterion which can be solved by exploiting the system redundancy.

In literature, many works exploit redundancy for other objectives, for example to keep an optimal manipulability of the end effector (Yoshikawa, 1990), (Bayle, 2001). Some authors, (Chabane, 2005) (Yoshikawa, 1984), have proposed manipulability measures related to the task to be achieved. Our goal is to propose a single model which uses robot redundancy and able to perform task even in case of joint default.

In addition, the model must take into account human machine cooperation (HMC) aspects. Indeed the person participates more or less to the control of the semi autonomous robot. In previous works (Rybarczyk, 2002) applied a Piagetian approach for improving HMC what is original in robotics. According to Piaget, the appropriation of a new tool by a user can be done following two complementary mechanisms: assimilation and accommodation. In the case of assimilation, a person transposes the way of using a tool, what is called a scheme (Fuchs, 2001), into the use of a new tool. For example, it is possible to use a screwdriver like a hammer by

hitting with the handle. In the opposite the accommodation requires to build new schemes what complicates the user task. Our idea consists in integrating to the model the ability to impose specific behaviours to the robot in order to privilege the implicit adoption of assimilation mechanism by the user.

It is difficult to solve complex problems with high dimension with traditional mathematical model. Distributed artificial intelligence makes it possible more easily by employing distributed methods able to solve local problem with the help of autonomous agents avoiding the implementation of a centralised fault management.

Our approach is based on a multi-agent architecture divided into two parts one for the arm manipulator and the other for the mobile platform. After a bibliographical study, we present our alternative multi-agent system to pilot a robotic arm. It is then extend to the command of a mobile arm manipulator.

2. AGENTS AND MAS

Computer science evolves from a centralised architecture (sequential treatments) to a distributed one (parallel treatments). So, very quickly appear autonomous agents, able to achieve individual task with no external help. MAS (Multi Agents Systems) (Ferber, 1995) try to solve more complex problem that could not be solved by a unique limited-mind entity. We can define an agent as an autonomous and flexible software entity (Weiss, 1999). Agent must be able to respond to environment changes. An agent has to perceive its environment, to treat the data and then to act. This is the sensori-motor loop. Stimuli may come from the inside (agent itself) or the outside (environment) of the agent. Then action is performed on the agent (internal states) or on the environment. Behaviour is the result of interaction between the agent and its environment.

It exists three ways to implement agent behaviours: cognitive, reactive, hybrid. Cognitive way divides the internal treatment into three parts: perception, planning and action. Agent must have its own world knowledge. It is able to analyse the situation, to anticipate and then to plan an action. Issues of this approach are limited speed and limited flexibility. It is also inadequate in the case of unexpected events. Reactive agents locally perceive their environment (and possibly its internal states) and deduce immediately the actions to be carried out only on this source of information. This principle is based on reflex action ((Zapata, 1992), (Wooldridge, 1999)). Hybrid approach merges the two last ones: a

basic reactive behaviour with a high cognitive referee level. The goal is to associate reactivity of agents with thinking and organisation ability of cognitive systems ((Brooks, 1986), (Chaib-Draa, 2001)).

The objective of multi agents systems (MAS) is to bring together a set of agents and to organise them to reach a high level goal. We can find several kinds of MAS. There are reactive systems which bring together agents and then try to get an emergent behaviour that can solve a higher level problem than each agent can do. Another type of MAS appeared with the need for making agents communicate between them in order to cooperate (Beer, 1998). L Parker (Parker, 1999) then uses a central machine which supervises the messages. The supervision now organizes groups of agents whose competences are different but necessary to the success of an objective.

Reactive MAS are often used to solve problems with the help of several entities having a poor own world knowledge, expedient and action ability. These MAS are implemented with limited-mind agent. The objective is to find a social emergent behaviour of an agent society able to solve a complex problem. For example, design of ants or bird behaviour uses this type of approach (Drogoul, 1993). Higher level MAS are frequently used in mobile robotics, especially in collective robotics (Lucidarme, 2003). Systems are based on criteria like gratification, altruism or cooperation (Lucidarme, 2002). A complex dialog is implemented between agents. A high hierarchical level entity is needed to oversee the task to achieve and to centralize the decisions and the communications. The objective is for example to coordinate several tens of mobile robots transporting containers on quays (Alami, 1998). Some others applications are developed for path planning, including obstacle avoidance (potential fields) associated with artificial life algorithm (Tournassoud, 1992), (Mitul). An alternative way of MAS use, more applied to robotics is arm manipulator model design. We can find few approaches (Duhaut, 1999) (Duhaut, 1993), which describe how to reach a Cartesian position without using mathematic inverse geometric model of an arm. This method seems to be interesting in our case. Each link is implemented like an agent. Task resolution begins with the end tool link. It tries to align itself with the goal and place its end tool on the goal by uncouple itself from previous link. Then, next link do the same with a new sub goal given previously. Figure 1 shows the beginning of the algorithm. It's a recursive one, a bit complicated and including thresholds. We only show three steps to give an idea of how it works. It's a 3 DOF arm. The

goal is the cross. Initial situation is first step. On step 2, the end tool link rotates virtually and uncouples itself from the arm to reach the goal. On step 3, second link rotates and uncouples it self from the arm to join the end tool link. Main characteristic to remember in this algorithm is that end links make bigger rotation than second one and so on. Expansion is not homogeneous.

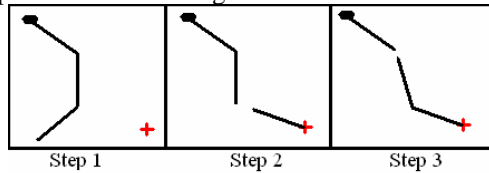

Figure 1 : D. Duhaut approach

Another use of MAS is for high level complex system control like fault detection (Guessoum, 1997) or data merging (vision, touch, sound ...) often using neuronal networks or fuzzy rules to find the more pertinent information. The word "agent" is usually employed in the meaning of "expert system".

3. ALTERNATIVE MAS APPROACH

3.1. Presentation of the approach

A joint agent is able to compute the position of the end of its end effector (in Figure 2), function of the angular value taken by the joint. The objective is to move as close as possible to the goal. The very simple agent behaviour is described in two steps:

Step 1: Agent virtually rotates in one direction and computes its new virtual position. If this one is closer than the present one to the goal, go to step 2 else agent virtually rotates in the other direction and go to step 2.

Step 2: The agent really rotates.

By repeating these two steps, the end effector moves as close as possible to the goal.

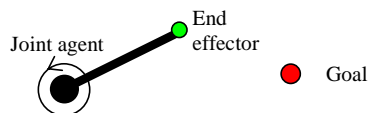

Figure 2 : Initial Agent position

We can now extend this behaviour to n agents. For an arm with several joints, reactive agents work

in a parallel way. They do not have knowledge of the global goal to reach. Agents are autonomous and the only criterion for each of them is a local distance minimisation. We look for an emergent behaviour that satisfies the global mission.

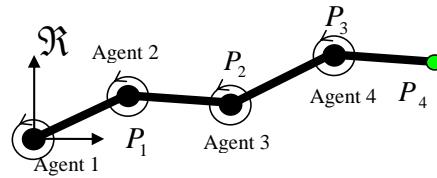

Figure 3 : four agent extent

Figure 3 shows a four agent example. Each agent need to know the position of the end effector and its movement according to the agent action. One solution is a recursive one. Agent number 4 knows the position of P_4 in relation with P_3 . What is interesting for it is to know P_4 in \mathcal{R} . To do that, it has to ask agent number 3 and so on. Base agent 1 is able to answer agent 2 and information then goes up to agent 4 which now knows P_4 in \mathcal{R} . The algorithm can also work if an external system, using video for example, can compute the position of the end effector and transmit it to each working agent.

The example of Figure 3 is a 2D one, which is simple to represent. The method is also efficient in 3D.

3.2. Results

3.2.1. Comparison with (Duhaut, 1993)

Figure 4 shows the difference between two approaches. The first (on the left) uses our MAS algorithm. The second (on the right) is given by Dominique Duhaut (Duhaut, 1993). We respectively note them MSMA and MD. Simulation presents a five joints arm manipulator on a 2D plane. The arm stretching is presented in three steps.

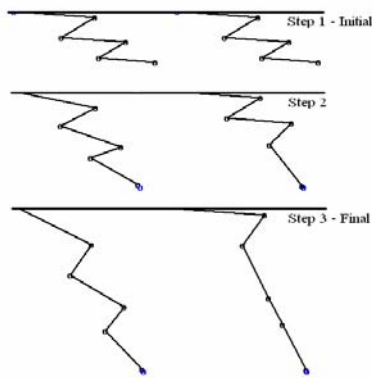

Figure 4 : Comparison MSMA and MD

We can see that during stretching, the MD approach tries to unfold members beginning by the last one. The MSMA system unfolds all members in the same time. So, final configuration is more homogenous and doesn't induce any alignment and thus limits singular positions. Moreover, visual aspect is more familiar to the user and human machine co-operation is made easier. When a person wants to take an object, he does not stretch himself to the maximum, he tries to keep a homogenous posture.

Figure 5 shows an arm folding. Again, we can see a more homogenous behaviour for the MSMA approach. There is no collision between limbs.

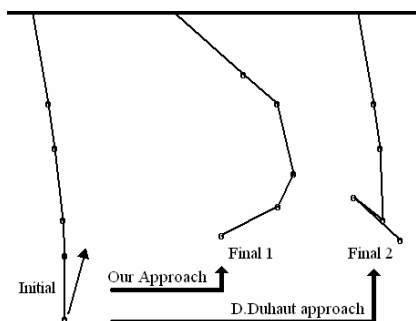

Figure 5 : Arm folds

3.2.2. Behaviour with broken joint

Duhaut's method (Duhaut, 1993) does not permit to simply take into account a joint fault. We only present results with our method. Figure 6 shows system behaviour including two broken joints (dashed limb and squared joint). We mean broken joint when the motor of the arm is out of order but not the incremental encoder which gives the joint position. If the encoder is also out of order, the arm

position is unknown and then it is impossible to control it.

The arm works with only 60% of its capacities. Reachable domain is delimited by two half circles. Dotted area represents the reachable space taking into account the reduced capacities. A systematic test has been realised, covering all the reachable space: 100% of the 4592 tested positions have been reached. The figure also shows three sample positions. This is possible because of the redundancy of the system.

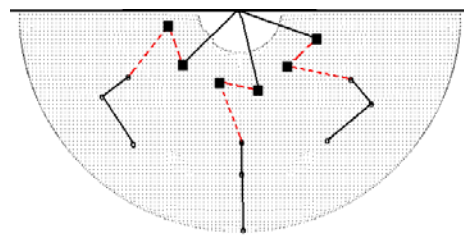

Figure 6 : two broken joints simulation with MSMA

3.2.3. Discussion

As agents work independently, all joints participate to the movement inducing a natural visual aspect of the arm for the user. For us, this property is very important because it gives the system a human behaviour and helps human-machine cooperation. The movement is distributed in all joints and the arm configuration stays far from singular positions. We can also see collision links avoidance on the arm folding. In the third simulation, without integrating any fault treatment, we can see that MSMA is fully fault tolerant if goal is reachable.

4. APPLICATION TO MOBILE ARM MANIPULATOR

The system to control is composed of a manipulator arm embarked on a mobile platform. The first objective deals with human-machine co-operation. The idea is to give to the system behaviours inspired from human being. For example, when a person wants to take a book, he/she tries to keep his/her arm not extended. If the book is too far to be taken by arm extension, the person walks in the direction of the book aligning the body on the hand movement direction. The second objective is to make the system more tolerant to some joint fault by exploiting redundancy. Our

approach uses a unique model, which is difficult to obtain with classical approaches. Indeed, in assistive field, it is important to maintain a good quality of service.

4.1. Mobile platform agent

As mobile platform control is more complex than the control of one arm joint, the agent used for the mobile platform is an hybrid one. Its cognitive capacities give the possibility to add some interesting behaviours.

Firstly, the mobile base has to move forward. Sensors for obstacle avoidance are located on the front of the mobile base.

The second implemented behaviour is to align direction of displacement of the mobile base with the arm manipulator. Indeed, when a person wishes to catch an object and must move to do it, he/she generally tights the arm forward in the direction of the movement of the body.

The third behaviour concerns deadlock. In certain cases, the mobile base and the shoulder arm joint both rotate at the same speed but one on the right and the other on the left. In that case, the gripper does not move and the system does not stop. The agent of the base is able to detect this type of situation. It introduces a waiting cycle by leaving the arm the priority to achieve the goal. Once this cycle ends, the agent tries again to align itself with the arm if it is possible.

Reactive behaviour is the same one as the arm agents.

4.2. Results

We now simulate the whole system algorithm. First we compare it with a classical mathematical method using manipulability constraints. Secondly, we simulate faults on some joints.

4.2.1. System and protocol

The system is a 3D mobile arm. It is composed of a mobile base equipped with two driving wheels and a free wheel to ensure stability. A manipulator arm with 6 DOF is fixed on the mobile base. All the following simulations show a straight line move of the arm hand tool on the up-right of the mobile platform. The task is to follow this straight line with a constant speed. Figure 7 describes the system and the associated mathematical frame. The displacement is perpendicular to the initial orientation of the base and oriented to the right (x

axis) and upward (y axis). Initial conditions are in Table 1.

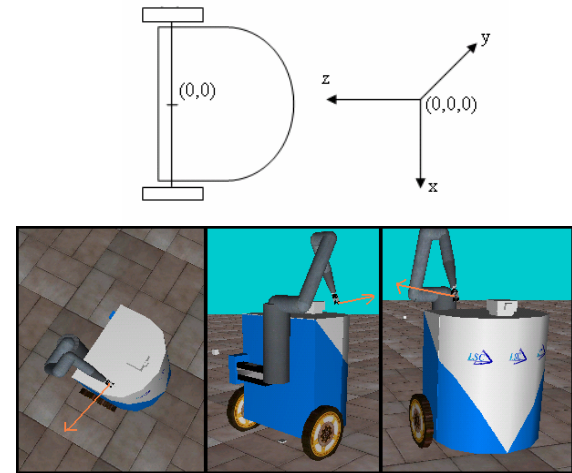

Figure 7 : System description

Object	Initial value
Platform position	(0,0,15) meters
Manus Joint 1	270 degrees
Manus Joint 2	120 degrees
Manus Joint 3	-125 degrees
End tool position	(18,79,-20) meters
Simulation steps	400
Sampling rate	60 ms
Shift wanted for each step	(0.42 , 0.12 , 0) cm
Total duration	24 s

Table 1 : Initial simulation conditions

On the first simulation, objectives are the following ones:

- the end effector must follow the desired trajectory with good accuracy
- the mobile base must move forward
- the mobile base have to align itself with the arm orientation
- the arm have to avoid extended configurations.

We compare our approach (MSMA) using agents introduced before with the MIM one which uses manipulability criterion (Chabane, 2005).

Secondly, we check fault tolerance ability MSMA approach. So, we simulate a breakdown of the shoulder and watch if redundancy with mobile base is able to permit to the system to reach the goal. We also simulate a breakdown of joint 2 to check behaviour of all the system.

4.2.2. Results

We do not show here hand tool trajectory. With both models, the move is correct with a good

accuracy (less than 3mm of difference between the real path and the desired one). There is no notable difference between them. Accuracy is linked to simulation step. We choose a high one of 60 ms because our real system has a 60 ms command loop.

Figure 8 shows platform trajectory and orientation. We can see two very different performances. MSMA works well. It always goes forward. It first turns slowly on the right, and then goes straight until the end and aligns itself with the arm orientation. We see a graining point in MIM simulation and the platform ends the task moving backwards.

During the move and with both models, the arm is never bended. Angle between joint 2 and joint 3 stabilizes to a 70 degrees value which is far from the 0 degrees singular value of the arm.

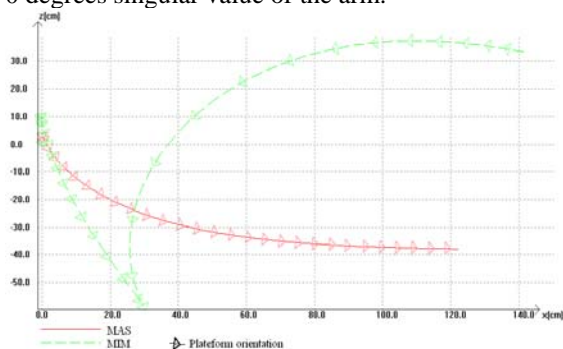

Figure 8 : MIM and MSMA platform moves

We now show how the system reacts in fault cases. MIM is not designed to be fault tolerant so its behaviour is not interesting here. It is why next simulations show only MSMA model in three samples faults situations:

- Arm breakdown joint 1 (shoulder) at 60°
- Arm breakdown joint 1 (shoulder) at 30°
- Arm breakdown joint 2 at 120°

Breakdown occurs at time 0. Figure 9 shows hand tool trajectory on x axis. We can see that MSMA satisfy objective even in fault situations. Results are the same on y and z axis. In the first two situations, redundancy between joint 1 of the arm and the mobile platform rotating movement is exploited. As hand tool follows the wanted path, we can say that the platform agent works well when the arm shoulder is broken. In that case, mobile platform moves forward but does not align with the arm orientation. Indeed, this alignment is performed by the redundancy between joint 1 of the arm and the mobile platform rotating movement and in that case joint 1 is broken. Moreover, the arm is not tightened and the angle between joint 2 and 3 is stabilized to 70 degrees. In the third situation, redundancy between joint 1 and joint 3 is exploited. Both of

them permit a vertical move (y axis). Once again the end tool follows the trajectory correctly. In that case, the mobile platform moves forward and aligns with the arm orientation. We can still notice that the arm is not tightened and that its posture remains far from singular position.

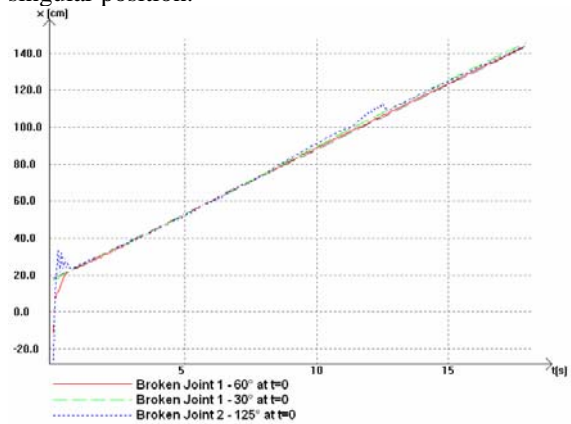

Figure 9 : Hand tool trajectory on axis x

4.2.3. Discussion

On the first simulation, we can see that the classical model used implies a more complex trajectory for the mobile platform on the whole system simulation. There is a graining point making the robot blind (it can not avoid obstacles anymore because ultrasonic belt is in front). It's due to the manipulability criterion used in this simulation. Our model shows a better behaviour, closer to a human one. The base goes forward and aligns itself on the arm orientation inducing a more assimilable move for the user. The use of independent agent helps to considerate directly human behaviour in algorithm. Also, the system is fault tolerant as shown in simulation. The end tool desired trajectory is reached even if arm joint 1 or 2 are broken. This ability is due to multi agent architecture which is able to run even if a component is defective.

5. DISCUSSION

First, with our approach, we do not cut out the final objective in sub goals which each agent would have to reach. Each one has a local work to do independently from others. We do not organize any co-operation. Here, we speak about emergent behavior. Indeed, one agent can not reach the goal alone. It needs others to achieve the task but it does

not know it. This kind of system provides very good result concerning fault-tolerance.

Secondly, this approach induces a goal for each agent. It is then possible to influence behavior of some agents without modifying that of the others. Then we can easily adjust or add behaviors to facilitate man machine co-operation. That is the case for example with platform alignment on the direction of the end tools in the same way than alignment of the human body on its hand direction. That leads to an easier assimilation of the system by the user. Indeed, with a classical model, to add a behavior requires the integration of constraints in the global model itself, which is not easy here.

Our approach has also its limits. If we integrate many behaviors, it is possible for the system to lose its wanted emergent behavior. The added constraints could be in conflict with the initial objective which is to reach the goal. The system then enters in non convergence cases. At the same time, we can lose fault tolerance ability. To avoid this kind of errors, it is first necessary for agents to keep autonomy compared to the goal they have to achieve and thus to be as simple as possible. Secondly, we have to include priorities in the local objectives of each agent. Reaching the goal has a high priority, going forward has a smaller one. Aligning base on arm orientation has a very small one. Thirdly, we have to implement deadlocking treatment by introducing delays in specific situations. In our system, these particular treatments are implemented in the agent of the mobile platform. We do not plan any problem resolution between agents. In our approach, we keep simple algorithm to avoid high hierarchical management. Indeed, high hierarchical management could then be compared with a system using mathematical models and including a fault treatment supervisor to switch between them.

6. CONCLUSION AND PERSPECTIVES

Our MAS system gives good results in relation to human behavior. Objects can be caught with an easily assimilable movement for the user (forward move, alignment of the base with arm orientation, simple trajectory with no turnaround, no bended arm). Accuracy is similar to classical method. It is fault tolerant without integrating any specific treatment. It makes easier the integration of special human driving mode. There is no need to compute mathematical model and especially the inverse model. Our MAS system algorithm is easy to implant and need only some geometric formulas and

thus very little computing power. It is a real time one.

We now have to implement algorithm on our mobile platform and create scenarios of displacement to judge the relevance of our algorithm on a real robot. We also want to improve object grasping. One possible way is to integrate a neuronal network that could help the system to have a better posture (eg: catching an object by the left if user is a left hand writer...). This improvement should lead us to manage with agents not only for the mobile arm but also for the orientation of the grip.

7. REFERENCES

- Yoshikawa, T.: *Foundation of robotics: "Analysis and control"*, The MIT Press, 1990
- Bayle, B., Fourquet, J.Y. and Renaud, M.: "Manipulability Analysis for Mobile Manipulators", ICRA'2001, Séoul, South Korea, May 2001, pp. 1251-1256.
- Khiar Nait Chabane; Philippe Hoppenot; Etienne Colle, "Mobile Arm for Disabled People Assistance Manipulability Analysis", International Computer Systems and Information Technology Conference, Algeria, July 2005
- Yoshikawa, T.: "Analysis and control of Robot manipulators with redundancy", In M. Brady & R. Paul. *Robotics Research: The First International Symposium*, MIT Press, 1984, pp 735-747.
- Yves Rybarczyk, Etienne Colle, Philippe Hoppenot: "Contribution of neuroscience to the teleoperation of rehabilitation robot", SMC'2002, Hammanet, Tunisia, 6-9 october
- Fuchs, J. Moreau, G et Papin, « Le traité de la réalité virtuelle », Nantes : Les Presses de l'Ecole des Mines, 2001
- Jacques Ferber, "Les systèmes Multi agents Vers une intelligence collective", IIA Informatique Intelligence Artificielle InterEditions, september 1995
- Weiss G., "A Modern Approach to Distributed Artificial Intelligence", The MIT Press, Cambridge, Massachusetts, 1999
- R. Zapata, P. Lepinay, C. Novalés and P. Déplanques, "Reactive behaviors of fast mobile robots in unstructured environments : sensor based control and neural networks." SAB, December 1992.
- Wooldridge M., Weiss G., "Intelligent Agents" *Multiagent systems*, - Ed.: MIT Press - 1999.
- R. A. Brooks, "A robust layered control system for a mobile robot", IEEE Journal of Robotics and Automation, p. 14-23, 1986.
- Chaib-Draa B., Jarras I., Moulin B., "Systèmes multi-agents : principes généraux et applications", *Principes et architectures des systèmes multi-agents*, J.-P. Briot et Y. Demazeau (Eds.) Hermès - 2001.

- Beer M., d'Inverno M., Luck M., Jennings N., Preist C., Schroeder M., "Negotiation in Multi-Agent Systems", Workshop of the UK Special Interest Group on Multi-Agent Systems (UKMAS'98) - 1998
- L. Parker, "Adaptative heterogeneous multi-robot teams", Neurocomputing, special issue of NEURAP'98: Neural networks and their applications, 28, p.75-92, 1999.
- Drogoul A, "De la simulation multi-agent à la résolution collective de problèmes. Une étude de l'émergence de structures d'organisation dans les systèmes multi-agents.", Thèse de doctorat, Université Paris 6. - 1993
- P. Lucidarme and A. Liégeois, "Apprentissage de comportements réactifs pour des ensembles de robots mobiles", JJCR17, Paris, pp. 33-39, IEEE best paper award - 2003
- P. Lucidarme, O. Simonin et A. Liégeois, "Implementation and evaluation of a satisfaction/altruisme-based architecture for multi-robot systems", proc. ICRA'02, Washington D.C., pp. 1007-1012 - 2002
- R. Alami, S. Fleury, M. Herrb, F. Ingrand and F. Robert "Multi-robot cooperation in the Martha project", IEEE Robotics and Automation Magazine, 5(1), p.36-47, 1998.
- Pierre Tournassoud, "Planification et contrôle en robotique Application aux robots mobiles et manipulateurs", Edition Hermes Traité des nouvelles Technologies série robotique – 1992
- MITUL SAHA, "Manipulator Planning and Obstacle Avoidance Using Genetic Algorithm", <http://members.rediff.com/mitulsaha/ga.html>
- Dominique Duhaut, "Distributed Algorithm For High Control Robotics Structures", International Conference On Artificial Intelligence – 1999 – Volume 1 p 45 à 50
- Dominique Duhaut, "Using multi agent approach solve inverse kinematic problem", proceeding 1993
- Z. Guessoum, "A Hybrid Agent Model: a Reactive and Cognitive Behavior", ISAD97, IEEE, Berlin, Germany, pp. 25-32 - April 1997.