

PERMANENT MAGNETS UNDER IRRADIATION AND RADIOACTIVE ALKALI ION BEAM DEVELOPMENT FOR SPIRAL 1

M. Dubois, J. Alcántara-Núñez, R. Alves-Condé, C. Barué, C. Canet, M. Dupuis, J.L. Flambard, R. Frigot, P. Jardin, C. Leboucher, N. Lecesne, P. Lecomte, P. Leherissier, F. Lemagnen, J.Y. Pacquet, A. Pichard, M.G. Saint-Laurent, GANIL, CEA/DSM-CNRS/IN2P3, F-14076 Caen, France

Abstract

Up to now, eighteen Target Ion Source Systems (TISSs) have been built and used for the production of radioactive ion beams on SPIRAL 1 facility, based on the Isotope-Separator-On-Line (ISOL) method. The TISSs are composed of thick carbon targets and of fully permanent-magnet Electron Cyclotron Resonance Ion Sources (ECRISs) of the Nanogan III type. After irradiation and a decay period of two years, the irradiated TISSs are dismantled and if their magnetic fields are still suitable, the ECRIS are used with a new target. Thereby thirty-two runs have been performed using new or renewed TISSs. After irradiation, the measured magnetic field sometimes reveals magnet damage. Our experience is reported here. In the second section, we present the progress on the NanoNaKE setup, which aims to extend the radioactive ion beams in SPIRAL 1 to the alkali elements, by connecting a surface-ionization source to the Nanogan III ECRIS via a compact 1+ ion beam line. The main issues and difficulties are discussed and the preliminary solutions are described.

INTRODUCTION

The use of high-energy fragmentation as well as the ISOL methods for exploring the structure of nuclei far from the stability has become one of the major activities at GANIL (*Grand Accélérateur National d'Ions Lourds*). The ISOL method, used in SPIRAL, provides radioactive ion beams, with subsequent acceleration by a K=265 cyclotron CIME, (*Cyclotron d'Ions à Moyenne Energie*).

Three cyclotrons are used to produce the primary beam which bombards the target of the TISS (Figure 1) placed in a heavily shielded cave. Exotic nuclei produced by nuclear reactions are released from the high temperature target (2000°C), effuse through a cold transfer tube up to a multi-charged ECR ion source. After extraction from the ECRIS at low energy ($\leq 34 q.keV$), the beam of interest is selected by a magnetic spectrometer ($m/\Delta m = 250$) and injected into CIME. The exotic beams can be accelerated in an energy range of 1.7 to 25 MeV/u and, after extraction, the proper magnetic rigidity is selected by GANIL's modified alpha spectrometer and directed to one of the existing experimental areas.

Two kinds of carbon target are used for the radioactive ion beam production, one dedicated to the production of He isotopes, the other to heavier gaseous element up to Krypton. The restriction to gaseous elements is provided

Radioactive Ion Beams

by a cold transfer tube, situated between the target cavity and the source chamber. Available intensities are given on the GANIL web site [1]

PERMANENT MAGNETS UNDER IRRADIATION

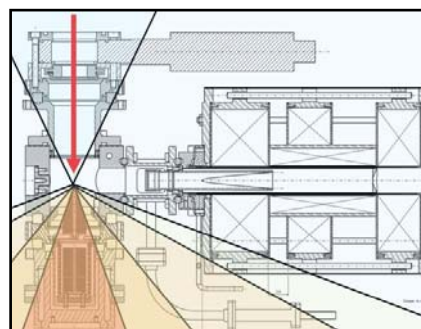

Figure 1: angular distribution of neutrons downstream from the target

The carbon target is placed close to the permanent magnets of the ion source (Nanogan III), which can then be damaged by neutron irradiation, leading to losses in axial and radial confinement of the source. For this reason, after a radioactive decay period of some years, the irradiated TISSs are placed in a glove box and dismantled. The target part is discarded as nuclear waste, and the magnetic field of the ion source is measured: if it is still acceptable, the ion source is reassembled with a new target.

During recent years, magnetic measurements have revealed more and more damage. Among the eighteen TISSs constructed since 2001, two types of degradation have been observed:

- (a) Degradation of the injection magnet (close to the target):

Figure 2 shows an example of the decrease of the axial magnetic field on the injection side, with no modification at the opposite (or extraction) side.

Measurements all around the injection magnet (Figure 3) show an average loss of magnetic field of about 20%, with a maximum of 40% on the target side.

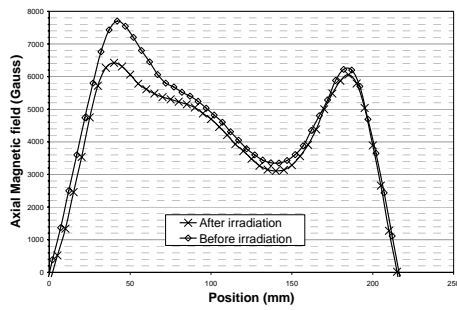

Figure 2: axial magnetic field before and after irradiation along the axis of the ECRIS.

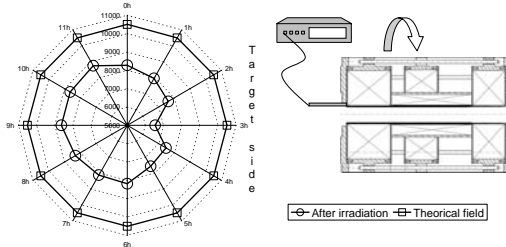

Figure 3: radial magnetic field measured on the injection magnet (left) and schematic of the measurement method (right).

(b) Damage to the hexapole:

A significant decrease of the radial magnetic field has also been measured on different TISSs (Figure 4).

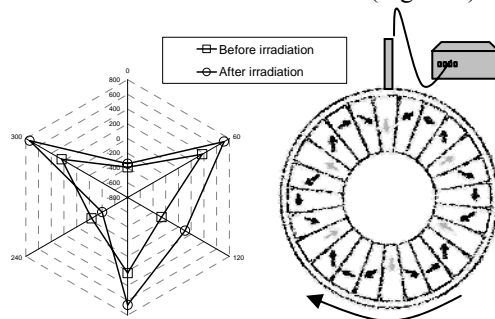

Figure 4: Radial magnetic field of the hexapole structure before and after irradiation (left side), and schematic of the measurement method (right).

This damage to the magnets can be explained by the coercivity of the magnets and by the intensity of the neutron flux

- Coercivity of the magnets

One important characteristic of the magnets is their coercivity, which corresponds to the maximum magnetic field they can withstand without magnetic changes. Moreover, this maximum strongly depends on the temperature (Figure 5). In the case of the NANOGAN III ECRIS, some magnets are subjected to fields close to the maximum.

Radioactive Ion Beams

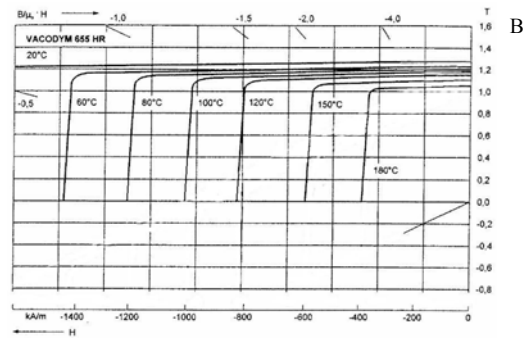

Figure 5: Coercivity of permanent FeNdB magnets (Vacodym 655HR) for different temperatures. B is the remanence field and H is the opposite magnetic fields.

- Particle effect on the permanent magnets

Neutrons, protons, gamma rays and light fragments produced by primary beams of energy ranging from 60 A.MeV to 95 A.MeV striking a carbon target can reach and damage the magnets [2]. Neutrons especially, with energies up to 95 MeV, have a high cross section for interaction with the boron contained in the magnets, and can thus damage them by microscopic structural modifications of the material.

The magnetic components of all the irradiated TISSs cannot be fully dismantled to do a fine diagnosis, particularly for the hexapole structure. Thus all the refurbished sources are tested on a dedicated test bench to ensure the same test conditions during the tests, allowing us to make a comparison of the performance of the respective sources. The charge state distribution of the argon spectrum (fig. 6) is taken as a reference to determine if a TISS is suitable for use in the SPIRAL ISOL process.

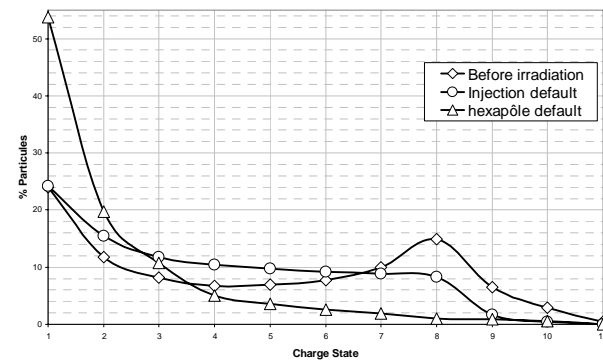

Figure 6: Influence of the state of the magnetic structure on the charge state distribution of argon.

Two types of target are used on SPIRAL, one for He production, and one for heavier gas production. Owing to the position of the He target, closer to the source axis than the other, and because the first degradation occurred with “He type” targets, we thought that the magnets were exposed to a more intense neutron flux.

This assumption was not confirmed, after we calculated the number of neutrons seen by each ion source.

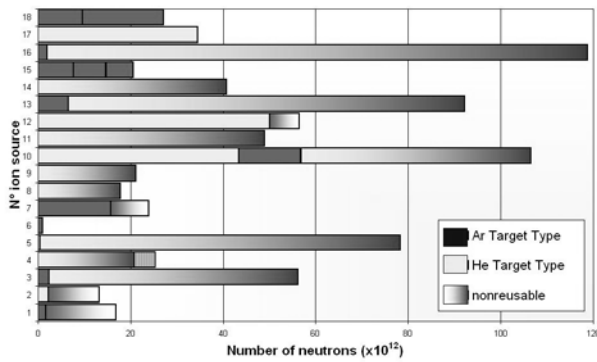

Figure 7: Reference number of each irradiated source versus total neutron number seen by the source. The different shading correspond to the type of target used for the run. A darker shade means the ion source cannot be reused.

CONCLUSION

We are not able to predict when the ion source will become unusable. The damage to the magnets depends on the neutron flux, but also on the primary beam features (energy, intensity, position on the target) and on the kind of target.

As on-line diagnosis is not possible while the beam is delivered to the physics experiments, we check the performance of each ion source at the end of a run, and check the magnetic field after the storage period and we also check the off-line performance of the source on a test bench before using the TISS in the production cave.

RADIOACTIVE ALKALI ION BEAM DEVELOPMENT FOR SPIRAL 1: ISSUES

In the framework of the production of multi-charged radioactive alkali ion beams in SPIRAL 1 at GANIL, a surface ionization source associated with the multi-charged ECR NANOGAN III [3] has been developed to produce singly-charged ions of Na and K. The system, called NanoNaKE, produces radioactive atoms in a carbon target, which diffuse and effuse into a surface ionizer. Once ionized, they are accelerated by an extraction electrode to form a beam, which is shaped by an electrostatic lens to go through a drift tube before entering the ECRIS chamber. This very compact system has demonstrated the possibility to convert $^{47}\text{K}^+$ ions into $^{47}\text{K}^{5+}$ ions, but with an efficiency somewhat lower than that expected [4].

These low efficiency results could have different origins:

- Losses during the 1+ beam transport by the spread in energy and angle induced by interaction of the 1+ ion beam with the residual gas coming from the hot parts of the system (i.e. the oven and ionizer) and from the ECRIS (feeding gas).

- Losses by interaction of the 1+ beam with the backward N+ ion beam extracted from the ECR ion source.

Since the target and 1+ ion source has previously been characterized, it has been removed and replaced by an alkali ion gun, which is easier to use: the emerging ion current easily can be measured, and it can be chopped, which is important to determine if the multi-charged ions observed at the exit of the ECRIS come from a slow conversion process (migration of atoms from the 1+ to the ECRIS and ionization) or from a fast conversion process (transport as 1+ ions from the 1+ to the ECRIS, capture and charge breeding). The behavior of the ion gun and the transport in the beam line have been previously simulated using the CPO (Charged Particle Optics) program [5] and SIMION [6] codes

Experimental measurements

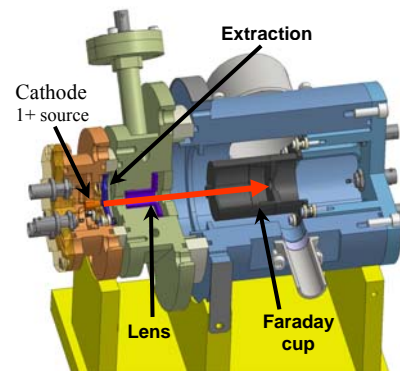

Figure 8: Setup for calibrating the alkali ion gun

The current and time calibration of the 1+ alkali ion gun was performed with a dedicated setup (Figure 8), for a maximum $^{39}\text{K}^+$ current of $15\mu\text{A}$.

After calibrating the alkalis ion gun, the system was installed on the NanoNaKE setup.

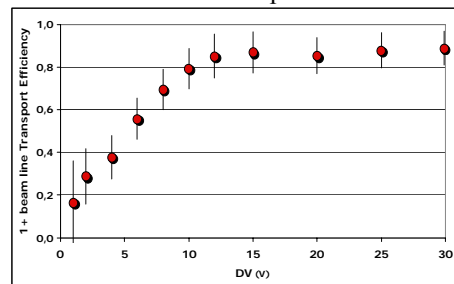

Figure 9: 1+ beam line transport efficiency versus voltage difference ΔV applied between the 1+ ion source and the ECR potential.

One of the main conclusions is that a voltage difference ΔV applied between the 1+ ion gun and the ECRIS potential must be higher than 12V to obtain a transport efficiency higher than 80%. But this value may be too high for ion capture by the ECR plasma, according to the “charge breeding” [7].

Owing to the design of the present beam line, several problems occur: at low ΔV , the current extracted from the alkali emitter decreases up to values difficult to observe, and the focus of the beam does not act as expected from simulations and the losses increase strongly. Moreover, the lack of physical separation between the different electrostatic electrodes induces a coupling of their effects. Finally, for a voltage of some hundreds of volts – which is a minimum to transport a 1+ beam while minimizing the losses – a Penning discharge appears on the beam line, inducing currents on the different electrodes much higher than the 1+ ion beam current, thus making it difficult to determine the transport efficiency.

- a gas pressure effect
- coupling of the electrodes
- limited value of extraction potential
- Penning discharge.
- a difficulty in simulating ion transport at low energy ($\square 10V$)

A new 1+ beam line (fig.11) is under construction, taking account all these problems. The next tests should be performed by the end of 2008.

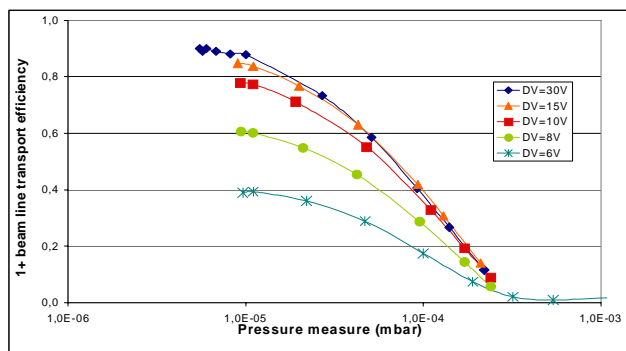

Figure 10: Gas pressure effect on the 1+ beam line efficiency.

As shown in Figure 10, one main origin of the losses during the 1+ beam line transport is probably the rest gas pressure. In our case, the order of magnitude of the pressure was estimated to some 10^{-4} mbar.

As the losses during the transport and the background of the ECRIS (when ON) are too large, it has until now not been possible to observe the charge breeding conversion.

CONCLUSION

A diagnostic study of the 1+ beam line has been made and several problems have been revealed:

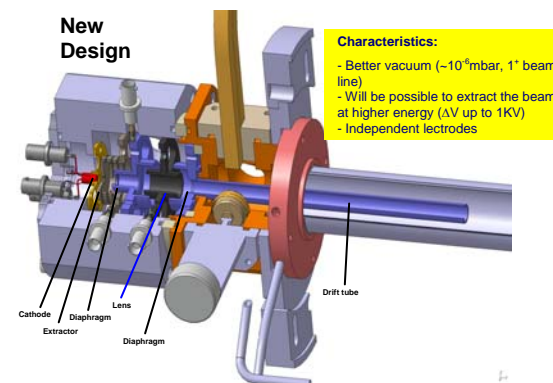

Figure 11: New 1+ beam line design

References:

- [1] GANIL web site : <http://www.ganil.fr>
- [2] N. Lecesne. These “Study of multicharged radioactive ions production on line”. (1997) p 112.
- [3] C. Eléon et al., Proceedings of EMIS 2007, to be published by Nucl. Instrum. and Methods in Physics Research, Section B (NIMB).
- [4] C. Eléon et al., Proceedings of ICIS07, to be published in Rev. Sci. Instrum.
- [5] CPO Programs, available on the web site <http://electronoptics.com>
- [6] SIMION Program.
- [7] N. Chauvin, PhD Thesis, Grenoble (2000)