

International Association for Management of Technology
IAMOT 2008 Proceedings

TECHNOLOGICAL FORECASTING AND ASSESSMENT OF BARRIERS FOR EMERGING TECHNOLOGIES

DMITRY KUCHARAVY
dmitry.kucharavy@insa-strasbourg.fr

ROLAND DE GUIO
roland.deguio@insa-strasbourg.fr
LGECO - Design Engineering Laboratory
INSA Strasbourg - Graduate School of Science and Technology
24, Bd. de la Victoire, 67084 Strasbourg Cedex, FRANCE

The typical ways to gather the latest information about emerging technologies is to elicit them from experts. Unfortunately, most of the existing approaches for collecting needed information produce biased outputs. Indeed, either overoptimistic or pessimistic estimates of future opportunities are produced. Both of them are undesirable, because they cause inadequate technology forecasts and management of technologies as well as misleading decision making.

In order to reduce bias while gathering information, a problem mapping approach is proposed that allows to extract and organize experts' knowledge in the shape of a network of interlinked contradictions.

The paper is organized the following way: First, the concept of resource limitation to define an S-curve of the technology life cycle is proposed. Several reasons behind the difficulties in assessing resource limitation are discussed.

Secondly, the concept of problem mapping through a network of contradictions is introduced. The methodology of mapping technological barriers is described. Some specificities from the practice of contradiction mapping are presented and discussed.

The third part studies how problem-contradiction mapping can be applied for the efficient assessment of technology barriers. These conjectures are supported by practical examples from arising energy conversion technology.

Finally, some perspectives of problem-contradiction mapping are given from the viewpoints of forecasting, inventive problem solving, management of technologies, and strategic planning.

Keywords: Technology Forecast, Laws of Technical systems evolution, Map of Contradictions, Scarce Resources, OTSM-TRIZ.

Introduction

The assessment of future technology barriers is widely applied for innovative design, technology forecasting and strategic planning (Armstrong, 1985, Preez *et al.*, 1999, Porter *et al.*, 2004). A realistic assessment of technology barriers contributes significantly to guidelines for a systematic problem statement; moreover it offers additional time for developing an integrated set of technical solutions answering cost reduction, productivity increase, quality growth, and environment-friendly evolution problems.

There is evidence to support the assessment of technology barriers well in advance: more time is available to respond to socio-economic challenges which may arise. If the assessment of long-term technology barriers is unreliable, it is necessary to significantly improve the efficiency of design methods to compensate for emerging uncertainties, and to develop an adequate response for new demands in a short period of time (e.g. lack of clean water or growing energy demand). However, if the assessment of long-term technology barriers is reliable, it makes it possible to develop an adequate technology for coping with the new requirements in an efficient way and without haste.

In this paper, we propose an approach that points out problems from technological, economic, social and environmental contexts that may occur while developing emerging technologies. The structure of the problem maps obtained with the proposed approach is

coherent with problem solving processes employed in innovative design using OTSM-TRIZ¹ concepts.

In order to reduce bias while eliciting the required information about new technology from experts, a problem mapping approach is proposed which structures experts' knowledge in the shape of a network of interconnected contradictions in three main steps. At first, a list of known obstacles and disadvantages of the desired technology is collected and discussed among experts. Second, the list of obstacles is transformed into a set of contradictions as well as a list of critical-to-X features². Third, a network of contradictions is constructed around the set of critical-to-X features using the set of contradictions. The map of problems which is based on contradictions improves impartiality. This is because of the rules applied to formulate the contradictions and the specific structure of the proposed contradiction network. The process of problem mapping is described below in the section Problem Mapping through a Network of Contradictions.

In the following section we present our vision of technology forecasting, the utility of the logistic S-curve of technology evolution, and the difficulties in assessing future resource limitations. The section 'Problem Mapping through a Network of Contradictions' is focused on the process of transforming non-structured expert knowledge into a credible network of contradictions. In the section 'Assessment of Technology Barriers' some results from practical application of the proposed approach are presented. The section 'Perspectives of Problem-Contradiction Mapping' proposes conclusions and suggestions for further work.

Forecasting, S-curves, and resource limitation

Nothing happens at random, but everything from reason and by necessity.
Leucippus

Technology forecasting

In this section, we focus on technological forecasting. Forecasting is the process which provides a result - technology forecast (TF). Their features, which are quite different, are given and discussed in separate paper (Kucharavy and De Guio, 2005). During the past decades, despite multiple attempts to structure and normalize the medium and long-term technology forecasting processes, most of the authors agree that they still need to become much more formalized and reproducible. Our research also contributes to these goals.

The main function of technology forecasting (TF), according to our working definition, is "to lead the decision making process towards profitable solutions with minimum uncertainties." The proposed function of TF is consistent with the function of technology road-mapping

¹ Theory of inventive problem solving (TRIZ is the Russian acronym usually applied) was developed mostly to address engineering problems. At the end of the 1970s the founder of TRIZ, G. Altshuller, anticipated further evolution of TRIZ towards a General Theory of Powerful Thinking, which will be useful to deal with non-engineering problems and complex cross-disciplinary problems as well. At the beginning of the 1980s G. Altshuller initiated research to develop this theory. OTSM is the Russian acronym usually applied to indicate the General Theory of Powerful Thinking.

² The concept of critical-to-X features is discussed in the section Problem Mapping through a Network of Contradictions.

(Kostoff and Schaller, 2001) which consists in “providing a consensual vision of the future science and technology landscape to decision makers.” Thereby, a high quality technological forecast should fit the following major characteristics: it should be accurate, credible and visionary. It should also portray the evolving relationships with adequate breadth and details. Moreover it should provide a comprehensive description of the evolution and relationship of most critical sciences and technologies in the past, present and future as well as a high degree of certainty, reliability and objectivity (bias-free) (Kucharavy and De Guio, 2005). The whole forecasting process, presented in Figure 1, can be split into six major phases that we shall now briefly describe.

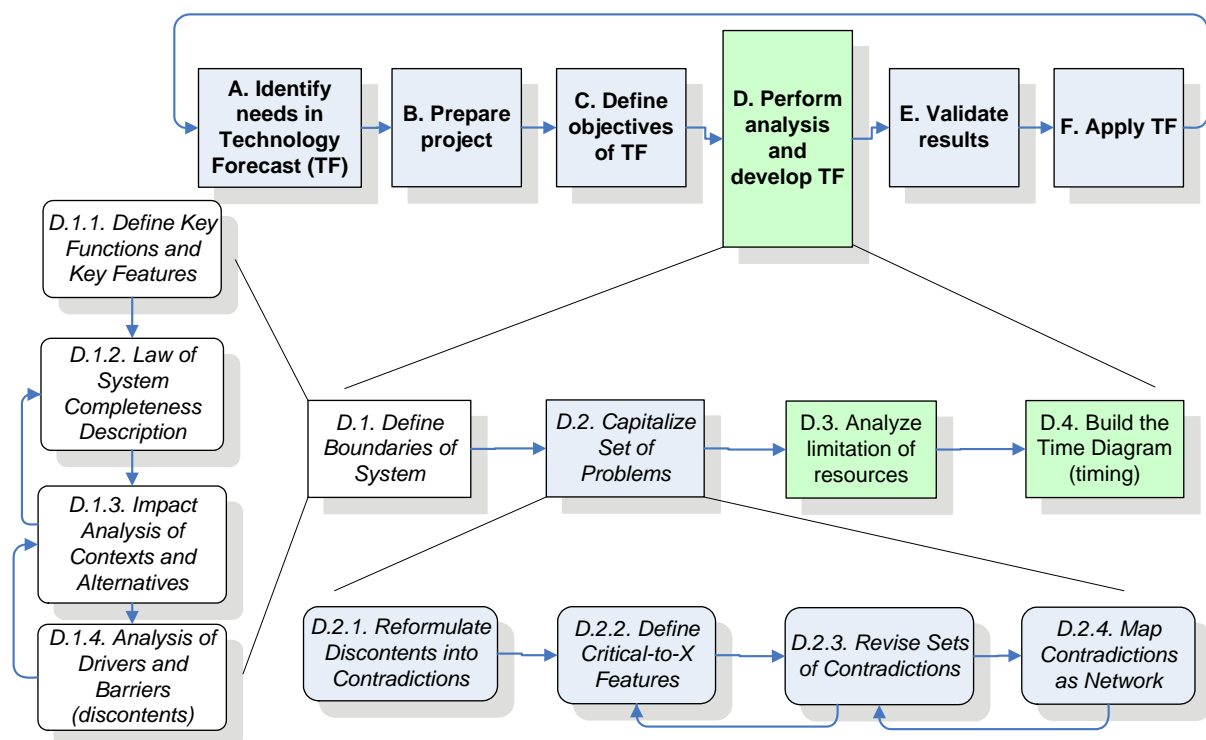

Figure 1. Components of technological forecasting process.

Identification of needs in technology forecast is the initial phase, when main objectives and expected outputs of the future study are defined. The expected outputs are supposed to support the decision making process. An analysis of decision making components is done in order to confirm the relevance of performing a technology forecast. Indeed sometimes it can be shown that the initial problem can be solved without TF. That is the reason why this phase ends with a decision: perform, or not, the next step of the technology forecasting process.

During the '*B. Prepare project*' phase, the main activities of the whole forecasting project should be planned and resources should be allocated. The roles of each human resource of the forecasting project have to be carefully prepared and explained. One can distinguish three main types of human resources: clients, core team, and external participants.

A client is both the customer and the user of TF for his own purpose. The clients should also be definitely committed to the forecasting process.

The core team, which is brought together during this phase, is in charge of defining the relevant references, writing documents, creating the structure of the forecast and filling it. The facilitator of the core team coordinates the efforts of experts from the team, external participants and clients to develop an entire forecast. It is necessary to plan the number and the duration of necessary meetings as well as to define external participants and partners (experts and reviewers).

External participants provide required data, information and experience. It is important to ensure regular interactions between the clients and the project team.

Other resources, like needed equipment, materials, and business trips, should be arranged. Major sources of information and data are identified within this phase as well.

Phase 'C. Define objectives' opens the 'per se' forecasting process. Requirements, questions and needs which are identified at previous stages are revisited from particular viewpoints (i.e. optimizing R&D, strategic planning for new product development, positioning the right product in the right market, etc.) Questions like the following should be answered unambiguously: What kind of question should be answered? What would we need a technology forecast for? How would we like to use the forecast? Scope and focus of study are defined; appropriate breadth of the forecast and depth of analysis are decided.

The future can be envisaged in different ways. Most of them can be classified into two groups: *normative* forecasts, when a desirable state of the future is foreseen and the study consists in finding the path from the present to this state; *exploratory* forecasts, when a possible state of the future is studied using available knowledge and data. Meanwhile, it should be decided which way to predict the future is appropriate for a given situation.

During this stage, one should define what kind of materials (information sources) could be used and what are the methods for obtaining relevant information.

Before going to the next phase, the results of phases A and B are revisited. Phase C is concluded by a detailed specification of the project, which is validated by the clients, the management, the coordinator, the core team and the main partners (Costa *et al.*, 2005).

'D. Perform analysis and develop TF' phase is the central part of the presented research. Activities of this phase are detailed in the second (D.i) and third (D.2.j) lines of Figure 1. A fragment of the analysis, according to the proposed procedure is presented below in the section 'Problem Mapping through a Network of Contradictions'.

The stage starts with the definition of the boundaries of the technological system to be forecasted. This is done using the concepts of system operator³ and laws of system completeness (Altshuller, 1979). This analysis selects relevant information to be gathered. Within the framework of this sub-stage four major steps can be identified (vertical line (D.1 activities) on the Figure 1): D.1.1 definition of key functions and key features of system; D.1.2 description of system in accordance with laws of system completeness and energy conductivity⁴; D.1.3 consideration of system in different contexts (technological, economic, social, and environmental) in parallel with comparison analysis of alternative systems

³ Multi-screen scheme of thinking

⁴ These two laws among others developed in the scope of the theory of inventive problem solving (TRIZ) help to define any system through a generic representation. For details, see (Altshuller, 1979, Altshuller, 1991).

(existing, emerging and possible); D.1.4 analysis of major drivers and barriers⁵ for the development of the system to be forecast.

Completing the definition (D.1) of the boundaries of the system prepares the necessary foundations for defining technological barriers in the shape of a problem- and contradiction-network. This set of tasks is brought together in the framework of sub-stage D.2 (capitalize set of problems). The content of this sub-stage can be presented through four main steps (third line on the Figure 1): D.2.1 reformulate information about technological barriers into formalism of contradictions; D.2.2 define critical-to-X features; D.2.3 revise and reformulate collected contradictions in accordance with critical-to-X features in order to get a consistent system of contradictions and critical-to-X features; D.2.4 to map obtained contradictions as a network of interconnected critical-to-X features, components of the system ('element-feature'), and opposite values of features as links (See Figure 5).

The next step 'D.3 analyse limitation of resources' applies the results of the problem mapping in order to summarise the scarce resources which cause the problems on the map. Networked problems are arranged in a table (e.g. Figure 6). Assessment of research and development activities is performed in order to get raw materials for 'time-to-solve-problem' evaluation (See Figure 6). The estimation of limiting resources in connection with the relevant science-technology and research-development activities allows for assessing time delays in a more reliable way.

Step 'D.4 build the time diagram' utilises the results of the problem mapping from step D.2.4 and the assessment of limiting resources from step D.3. Networked problems are arranged in accordance with the estimated time for answering them (solved, tested and implemented). The left vertical axis presents critical-to-X features, ranked in accordance with the selected context (See Figure 7). Various contexts (technological, economic, environmental, and social) can produce a different order of critical-to-X features on the left vertical axis. Therefore, the final conclusion within the interpretation of the constructed maps varies depending on the considered context.

The results of phase '*E. Validate results*' depend entirely on the satisfaction of the client with the results of TF. There are several approaches to validate the developed forecasts. Some research focuses on the validation of the forecasting process (Principles of Forecasting, 2002). Other research follows the traditional method for evaluating the results. In order to facilitate the validation stage in any case, the typical solution of peer review with external experts and partners can be applied during and in between working sessions. For consistent validation of TF the major clients and partners should agree on the key functions of the analyzed system, key enabling technologies and major trends in the evolution of the surrounding super-systems.

'*F. Application of TF*' phase depends essentially on the needs and formulated objectives as well as the transparency, intelligibility, credibility and consistency of the technology prediction. Studies and research into the future are applied for decision making, strategic planning, policy development, education and much more. Furthermore, each widely

⁵ Questions, ambiguity, and problems.

communicated forecast contributes to growing awareness, consensus building, sharing of information and networking. Therefore, applied technological forecasts make a considerable contribution to the needs in coming predictions.

With several projects in the field of energy conversion technologies we are able to demonstrate that a methodology to develop TF can be constructed on the basis of contradiction networking.

The contribution proposed and discussed later in this paper concerns the phase '*D. Perform analysis and develop technology forecast (TF)*' of technological forecasting.

S-curve of technology life cycle

The regularity of systems' evolution as an initial slow change, followed by a rapid change and then ending in a slow change again are observed since statistical observation was established in the mid 18th century. Various scientists and researchers discovered, reinvented, and adapted the curves of nonlinear growth many times for different domains of knowledge. As a result, S-shaped curves possess a lot of different names: Logistic curve, Verhulst-Pearl equation, Pearl curve, Richard's curve (Generalized Logistic), Growth curve, Gompertz curve, S-curve, S-shaped pattern, Saturation curve, Sigmoid(al) curve, Foster's curve, Bass model, and many others.

The logistic function as a model of population growth was first introduced by Belgian mathematician Pierre-Francois Verhulst (1804-1849) in 1838 (Weisstein, 2003). Verhulst derived his logistic equation after he had read 'An essay on the Principle of Population' of English demographer and political economist Thomas Malthus (1766-1834). First, the logistic equation was introduced to describe the self-limiting growth of a population. This equation sometimes called the Verhulst-Pearl equation according to its rediscovery in 1920 by American zoologist and one of the founders of biometry Raymond Pearl (1879-1940).

The law of natural growth over a period of time, described by the logistic S-curve, can be interpreted by periods of birth, growth, maturity, decline and death for any system. This set of periods is often called the life cycle of a system.

A bell-shaped curve is usually applied as a template to represent the rate of growth within a time span (see Figure 2). Whereas cumulative growth (cumulative number of "units" until any given points in time) follows an S-shaped curve. Thus the S-curve becomes a visual symbol of cumulative growth.

Natural growth of autonomous systems in competition, according to multiple observations, might be described by a logistic equation and a logistic curve respectively. Natural growth is defined as the ability of a 'species' (systems) to multiply inside finite 'niche capacity' (carrying capacity) through a time period. The essential meaning of the simple logistic function is 'the rate of growth is proportional to both the amount of growth already accomplished and the amount of growth remaining to be accomplished.'

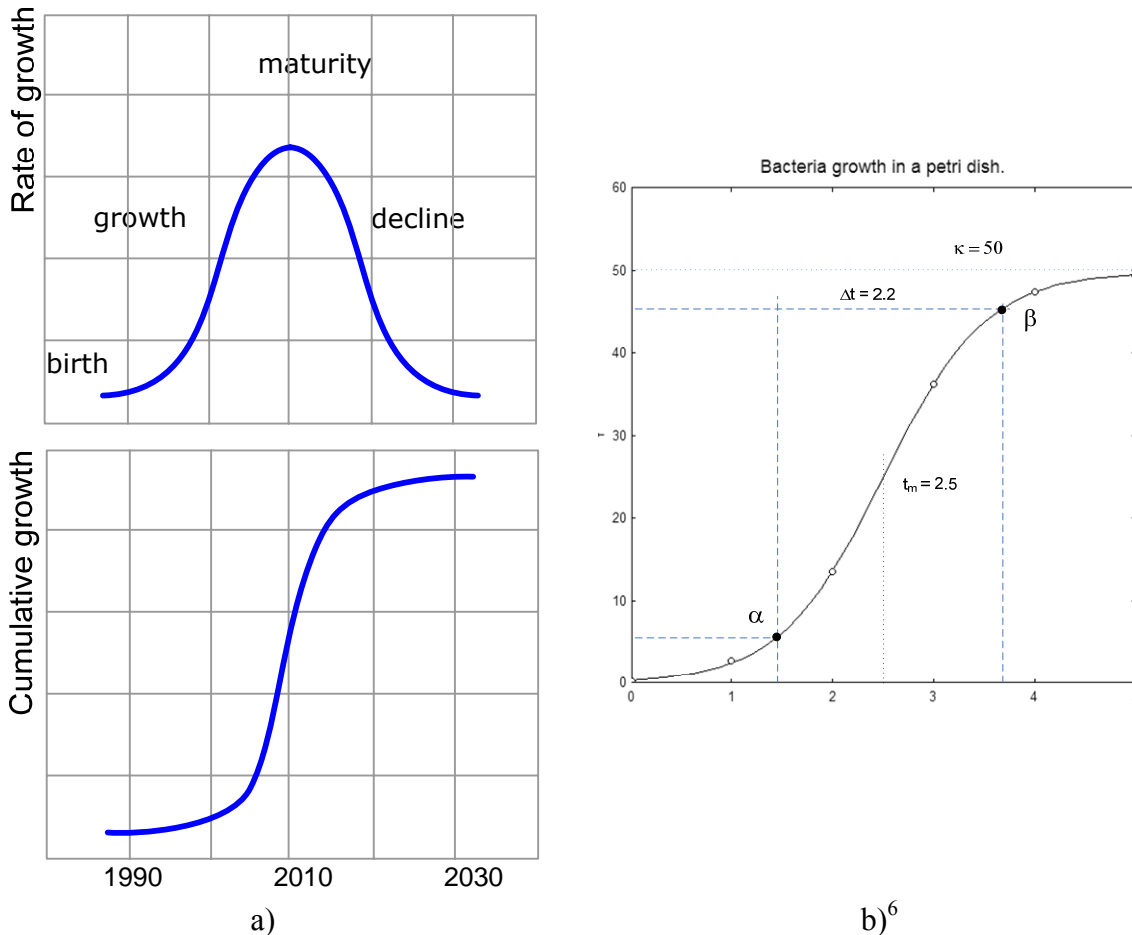

Figure 2. Life cycle bell-shaped curve and S-curve of cumulative growth.

We believe that the forecasting power of the logistic S-shaped curve is due to the underlying concept of limiting resources. This concept, which lies at the foundation of any growth process, has different names depending on the area: scarcest resources (geochemistry), restricted resources (economy), limitation of resources (TRIZ⁷), resource constraint (theory of constraints), niche capacity (market research), carrying capacity (ecological systems), etc. In most cases, applying an S-curve for forecasting induces the correct measurement of the growth process that in turn can be applied to identify the law of natural growth quantitatively and reveal the value of the ceiling (upper limits of growth) and steepness of the growth (slope of curve).

It is obvious that, the more precise the data and bigger the section of the S-curve they cover, the lower the level of uncertainties. In other words, one can identify a more accurate ceiling

⁶ Adopted from (Meyer *et al.*, 1999)

⁷ Theory of inventive problem solving (TRIZ is the Russian acronym usually applied for).

and steepness with a larger data set. The reliability of the forecast of the ceiling is higher when the available data covers more than half of the S-curve. This fact causes difficulties when applying an S-curve forecast for emerging technologies that have not yet passed the "infant mortality" threshold (point α of Figure 2b).

What can be done when there is a lack of data?

In order to manage uncertainties due to insufficient data, a study on determining uncertainties was carried out for S-curves. Alain Debecker and Theodore Modis carried out a systematic study of the uncertainties to be expected as a function of the number of data points, their measurement errors, and how much of the S-curve they cover (Debecker and Modis, 1994). Their study helps to establish the correlations between the uncertainties on the determined parameters. As a result, several tables are proposed to manage uncertainties with a certain confidence level for fitting S-curves on data.

In the scope of TRIZ, instead of a naïve method (see Figure 3 for details), the causal method is applied for compensating for the lack of data for emerging technologies. Originally, the number of inventions, the level of inventions, and profitability of innovations were applied as causal variables (Altshuller, 1979). More recently it was proposed to apply the focus of the invention, complexity of the system, and number of competitors as causal variables (Mann, 2003). Furthermore, G. Altshuller discussed three types of limiting resources a system is faced with during its evolution: limits of system resources, limits of available resources and physical limits of resources in super-system (Altshuller, 1979, 1991).

A strong point of TRIZ-approaches is their concordance with objective laws of technical evolution. For emerging technologies in the early stages of their evolution such approaches have high visionary power. A drawback, from the viewpoint of technological forecasting, is that they produce qualitative results, with a low level of repeatability. Indeed, two different teams using the same approaches and similar sets of information produce results that may be similar about what will happen but different about when (time) and where (location) it will happen.

In order to overcome the limited repeatability and improve the reliability of forecasts for emerging technologies using a logistic S-curve, the value of limiting resources should be used as a causal variable. It facilitates forecasting growing limits for emerging technologies in particular when the lack of data does not allow the naïve method to be applied. For mature technologies with sufficient data sets, assessment of scarce resources can be applied in parallel for ensuring the results obtained from the naïve method.

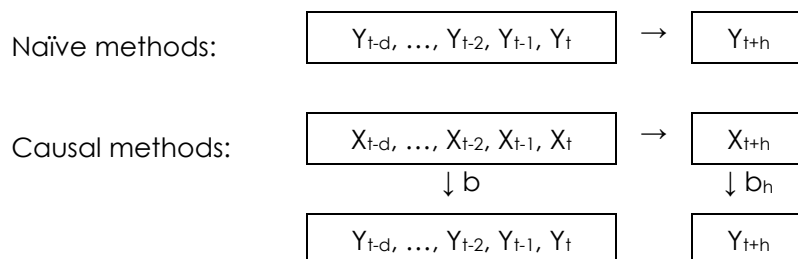

Figure 3. Naïve and Causal methods. Adapted from (Armstrong, 1985).

Naïve methods apply past data about the variable to be forecasted (Y) in order to identify the trends and extrapolate them into the future. Causal methods apply causal variables (X) to foresee future changes of target variable (Y). A causal variable (X) is one that is necessary or sufficient for the occurrence of an event (Y). It is assumed also that X precedes Y in time. Past data about causal variable (X) are used in order to identify trends and apply this knowledge to foresee future values of target variable (Y).

It is the availability of resources for operating a given technology that shapes the steepness and characteristic duration of an evolution. Therefore, assessment of limiting resources can be applied for forecasting of the asymptotic limit of growth and other parameters of technology changes over time. This supposes the following hypotheses: a) the link between the resource and the S-curve is well defined and precise; b) the value of the scarce resources can be defined in an accurate and reliable way.

What makes forecasting difficult?

The essential generic problem can be formulated in the following way: in order to learn about the future, some knowledge of it is necessary; however only knowledge about the past and present is available. One of the ways to deal with this issue is to apply knowledge about problems instead of using only information about present solutions (i.e. existing technologies).

Nevertheless, when collecting a set of problems presented by emerging technologies the following question arises: how does one assess the advantages and shortcomings of emerging technologies before having experienced them? This question can be reformulated as a conflict: In order to decrease risks and make a trustworthy assessment of risks and uncertainties, we should have knowledge; however, we do not have the required knowledge, because the technology is entirely new.

When trying to cluster the multitude of reasons behind the complexity of assessing resource limitations, five major groups can be identified:

- *Noise and Signal issue.* Appropriate and relevant information for forecasting the future should be collected and selected.
- *Dynamic nature of limited resources.* At different stages of a system's evolution, different resources can be identified as 'scarce resources'. For instance, at a certain stage it can be the size of a machine, at the next stage it can be the energy efficiency, at a third stage it can be by-products or dangerous waste products.
- *Issue of compatibility of multiple contexts.* In order to provide a consistent and reliable description of the future, it is necessary to take into account not only the technological resources of the analyzed system, but also economic resources, social resources and environmental resources. How does one measure and unify all these resource limitations?
- *Bias of specialists and experts.* For emerging technologies, it is necessary to elicit needed data and information from experts (implicit knowledge) and from emerging sources (explicit knowledge) to overcome knowledge shortages. How does one bypass preconceived notions, personal and organizational agendas?
- *Dynamics of necessary and sufficient description.* In theory, the analyzed system is considered as part of a super-system or environment. In order to identify a system it is necessary to define its boundaries, properties, and its interaction with

the super-systems. Moreover, the forecasted system draws resources from the nearest super-systems. In order to identify scarce resources, it is unavoidable to distinguish the dynamic of the relationship between the system and its environment. According to the law of Transition to the Super-system from TRIZ, system boundaries change over time. Are artificial boundaries being drawn? How does one follow the changes of system boundaries in the future?

The presented groups of reasons behind the complexity in assessing resource limitations are not exhaustive. Nevertheless, according to our study, they seem the most critical to address.

Problem Mapping through a Network of Contradictions

If you have to forecast, forecast often...

Technological barriers are problems; they are limits imposed by the impossibility of applying a certain technology to meet the specific socio-economic needs. Technological barriers can be caused by environmental, social, economic or technological issues. As soon as any technology requires a set of resources to operate, the limitation of resources is considered as the root cause of incapacity of the technical system to meet quality standards. This is the reason why it is crucial to foresee and overcome future technological barriers.

In this section the example of stage 'D. Perform analysis and develop TF' with the main focus on sub-stage 'D.2 capitalize set of problems' is presented with necessary definitions for special terms. Please, see Figure 1 and sub-section 'Technology forecasting' above for reviewing the model of the entire technological forecasting process.

The objective of a study about Small Stationary Fuel Cells (SFC), performed in collaboration with the European Institute for Energy Research (EIFER), Karlsruhe, Germany, was defined as answering the two following questions (Gautier et al., 2005):

1. What is the best path towards the ideal system of Small Stationary Fuel Cells (SFC)?
2. What will be the evolution of the SFC in comparison to conventional technologies?

The results needed to be presented in such a way that they were easy to understand and to communicate to the target audiences.

Definition of system boundaries

In accordance with the formalism of the law of system completeness and the law of energy conductivity (Altshuller, 1991), components of the SFC were classified as "engine", "transmission", "tool", and "control". "Product" and "energy source" were identified as well. This description was applied as a model of the system for the whole study into the future of the SFC.

A synthesis of drivers and barriers from multiple viewpoints helped to define four major contexts to be taken into account in the forecasting study: sociological, economical, technological and environmental.

Definition of the key features and analysis of alternative technologies provide additional necessary components to formulate an interim version of 'critical-to-X' features. In this specific study about SFC, it was decided to focus on market requirements. Therefore, 'critical-to-market' features were identified as metrics that drive the evolution of SFC. The

consistency of the whole analysis was ensured by revising the results of previous steps before performing the next step (back arrows on Figure 1).

An important result derived from 'D.1 definition of system boundaries' sub-stage was the collection of discontents and problems around the emerging SFC technology. The list of identified discontents, critical questions and problems was applied within step 'D.2. capitalize set of problems' as raw materials.

Capitalization of the set of problems

The definition of contradictions is useful for knowledge management in the scope of practical forecasting. The capitalization of problems through the definition of contradictions helps the working team remove bias from the gathered knowledge. The process of problem reformulation generates additional, usually unexpected, viewpoints of the explored system and discloses non-obvious problems.

Reformulate discontents into contradictions

This step consists in describing problems in the form of contradictions according to the specific pattern given in (Khomeenko *et al.*, 2007). The applied model of a contradiction includes the following components:

- Desired Result – the result(s) that correspond to the objectives of problem solving. In other words, this is a Result that should be achieved at the end of the problem solving.
- Element – is a part of a whole system, piece of work, concept etc.
- Feature – is a property of the element that is noticed because it seems important, and has been identified in the problem definition. Feature of Element at the initial stages of Contradiction formulation is tightly linked with a known way to deal with negative result(s) (undesirable result or property of the system).
- Value of Feature – the amount of feature represented by number or by quantitative adjectives. Values of Feature are both responsible for undesired and some expected result(s).
- Result(s) – is something that happens or exists because Feature of Element takes such a Value. Result can be presented as a positive or negative after-effect.

For instance, in order to operate the low temperature SFC the external water supply should be applied. If the external water supply is applied, it improves the durability of the fuel cell, but it worsens the maintenance intervals of the whole installation. After intensification, such a problem can be presented as a contradiction: external water supply should be present to perform best durability; but external water supply should be absent, in order to perform best maintenance intervals for installation.

For the presented contradiction, the 'external water supply' is the feature of element – 'water management in the system'. One value of the feature is 'present'; the opposite one is 'absent'. When the feature takes the value 'present' the positive result is 'adequate durability of system', but there is a coupling negative result: 'inadequate maintenance intervals'. When the feature

takes the opposite value 'absent', the results switch over. The desired result is the combination of positive after-effects from opposite values of the contradiction: adequate durability of system with satisfactory maintenance intervals. In other words, external water supply should be absent, but its functionality should be performed.

The step 'Reformulate discontents into contradictions' results in two sets of contradictions for each of the SFC technologies. Some problems were common when some of them were specific for a particular technology. Each set consists of dozens of contradictions.

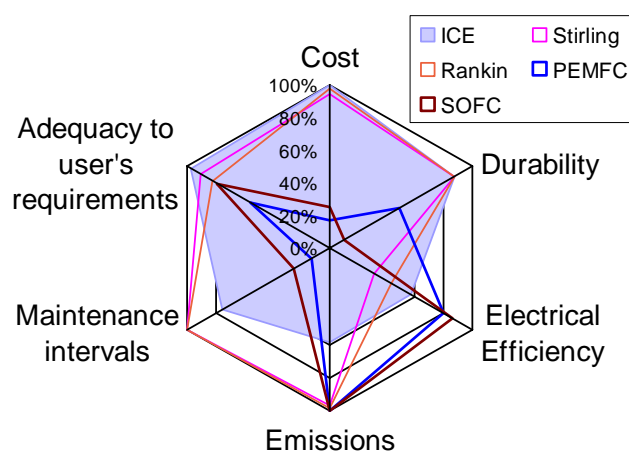

	PEMFC			SOFC			
	actual	market target	performance	actual	market target	performance	
1. Cost:	17%	100%		25%	100%		
1.1. Installed Cost NG, EUR/kWh	15000	4000	27%	10000	4000	40%	
Imp Importance: High							
1.2. Operational cost, EUR/kWh	0.3	0.02	7%	0.2	0.02	10%	
Imp Importance: High							
2. Durability:	40%	100%		10%	100%		
2.1. Durability in operating conditions, years	2	15	13%	2	15	13%	
Imp Importance: High							
2.2. Cycling ability, number of stops per year	125	125	100%	10	125	8%	
Imp Importance: High							
2.3. Start up time, min	90	15	17%	240	15	6%	
Imp Importance: Moderate							
3. Energy Efficiency, %:	85%	100%		93%	100%		
3.1. Electrical efficiency, %	28%	35%	80%	30%	35%	86%	
3.2. Thermal efficiency, %	59%	65%	91%	55%	50%	100%	
3.3. Ratio Electrical power / Thermal Power	0.51	0.04		0.04	0.04		
4. Emissions:	100%	100%		100%	100%		
4.1. Substances, ppm	40		100%	CO + Hcpm	100%	CO + Hcpm	100%
Imp Importance: High							
4.2. Noise, dB	0		100%	NOx-34 ppm	100%	NOx-34 ppm	100%
Imp Importance: High							
5. Maintenance interval, h	1000	8000	13%	2000	8000	25%	
Imp Importance: Moderate							
6. Adequacy to user requirements:	50%	100%		79%	100%		
6.1. min. temperature return, °C	50	60	83%	500	70	100%	
Imp Importance: High							
6.2. min. flow temperature, °C	70	80	88%	900	90	100%	
Imp Importance: Moderate							
6.3. size, m	1.5x0.85x1.7	0.5x0.5x1		0.55 x 0.55 x 1.60	1.60		
Imp Importance: Moderate							
6.4. weight, kg	2.17	0.25	12%	0.48	0.25	52%	
Imp Importance: High							
Imp Importance: Moderate							
Average for technology:	39%	100%		40%	100%		

Figure 4⁸. Critical-to-market features values for high temperature, a low temperature SFC with natural gas as the fuel. Larger gap between desired value of feature and actual one indicates more problems to be solved concerning the way to commercialize an emerging technology. (Information provided courtesy of EIFER, Karlsruhe (Gautier, L. et al., 2005))

Define critical-to-X features

Cross-analysis of the formulated contradictions and specifications of existing power generating systems provided the first raw version of critical-to-market features. This set of critical-to-market features was refined using the results of step 'D.1.3 impact analysis of contexts and alternatives.'

When critical-to-market features and their values were defined, the large gap between the existing values of features and what was required was identified (see Figure 4). While mapping the contradictions one asks 'What are the problems that prevent us from closing the gaps?' For instance, if in the network of contradictions, the gap on the 'cost' axis is not presented by an adequate problem value, it is a warning sign of the inconsistency of the two parts of the study. It is vital to keep consistency and to regularly harmonize the set of critical-to-X features and the map of contradictions during the study.

⁸ ICE – small stationary combined heat and power generator (CHP), based on internal combustion engine; Rankin - small CHP, based on organic Rankin cycle; SOFC - small CHP, based on high temperature Solid Oxide Fuel Cell; Stirling - small CHP, based on Stirling engine; PEMFC - small CHP, based on low temperature Proton Exchange Membrane Fuel Cell.

Revise sets of contradictions

At this stage of the study, previously formulated contradictions were revised and expressed in accordance with defined critical-to-market features. As a result, the number of contradictions decreased through aggregation and unification. Meanwhile, the explicitness of problem definitions was improved.

Map contradictions as a network

The interactive nature of mapping the contradictions as a network requires a regular revision of the collected set of contradictions and set of critical-to-X features in order to keep the consistency of the analysis and processed knowledge. This mechanism contributes to a bias-free assessment of technological barriers. In practice, after several reviews the resulting map can look quite unexpected for working team members. The process of map construction contributes to a consensus within the working team about the subject of study as well.

For example, within the study about small SFC a set of critical-to-market features was formulated. When critical-to-market features and their values were defined, the large gap between the existing cost of SFC and required value of this feature was identified (see Figure 4). While mapping the contradictions one asks 'What are the problems that prevent us from closing the gaps?' If in the network of contradictions, the gap on the Cost axis is not presented by an adequate problem value, it is a warning sign of the inconsistency of the analysis. Critical-to-X features analysis and the network of contradictions should be harmonized.

An example of the resulting network of contradictions for low temperature SFC (PEMFC) SFC below 5 kWe power is presented on Figure 5. The network was constructed for six critical-to-market (CTM) features. How should one read the concepts on the map? For instance, 'Current distribution inside cell of stack' (the block which is second from the top on the right-hand side in Figure 5) has to be uniform in order to satisfy the electrical efficiency in use (CTM#3); but it has to be non-uniform in order to satisfy the distribution of hydrogen rich gas and oxygen inside cell of stack (which is tightly linked with CTM#1, #2 and #3).

Self-organization of the mapped problems is an interesting secondary effect. It should be noted that problem mapping using contradictions requires a high level of expertise in the analysed technological domain. This requirement was recognised as valuable for increasing the competence of specialists in emerging technologies. However, it can be a cause for slowing down the forecasting process when the required expertise is not available or the working team reaches the limits of its knowledge.

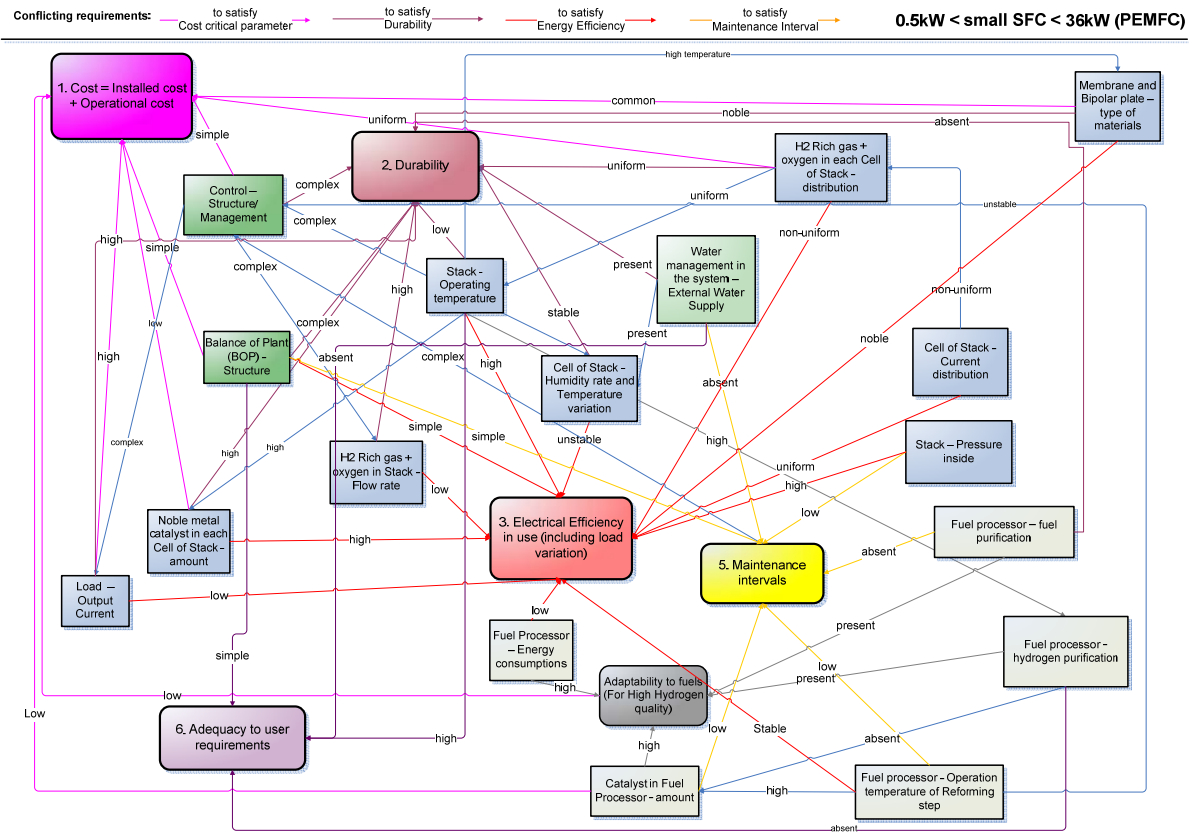

Figure 5. Network of contradictions for low temperature SFC. (Information provided courtesy of EIFER, Karlsruhe (Gautier, L. et al., 2005))

Analyse limitation of resources

At this stage the limited resources for the defined network of contradictions are examined. Limited resources in a technological context can be described through the shortage of certain substances, inadequate flow of energies (fields), restrictions of space and limitations of time. In order to overcome the limitations, the identified problems should be resolved and limitations of resources should be overcome. In practice, it takes time to develop concepts, to design a solution, to explore the obtained solutions, to perform field tests and to diffuse the proposed solution (Rogers, 2003, Llerena & Schenk, 2005).

Element-Feature	Value 1	Value 2 (opposed)	Limiting resources	S&T, R&D activities, Project names	Exploration, years	Experimentation & examination, years
Noble metal catalyst in each Cell of Stack - amount	Low	High	Platinum needed at low temperature (<400°C)	<Project 1 name>	<Project1 duration>	<Time for field tests>
<E2 – F2>	<V>	<Λ>	<Substance, Field, Time, Space etc.>	<Project 2 name>	<Project2 duration>	<Time for field tests>
<E3 – F3>	Present	Absent	<Time, Space etc.>	No specific project	<Project3 duration ??>	<Time for field tests ??>
<...>	<...>	<...>	<...>	<...>	<...>	<...>
Fuel processor - Quality of outlet gas	Low	High	complex fuel processing technology for NG and biofuels	<Project N name>	<Project N duration>	<Time for field tests>

Figure 6. Resource limitation assessment results (real data are substituted by variables due to intellectual property limitations).

Let us illustrate the analysis of resource limitation using the example of low temperature SFC. First, the contradictions are extracted from the network in the specific form: element, feature and the opposite values of features. Second, limited resources for the formulated problems are assessed. The results can be collected in a table. Third, research and development (R&D) activities are identified for each “problem-limited resource” pair.

For instance, there is a problem extracted from the network of contradictions: applied materials for membrane in stack and for bipolar plate must be noble and must be common. For this problem we are limited by substance resources: nafion and graphite bipolar plate. In order to see how and when the identified problem can be solved, R&D activities were explored to address the problem. The European projects AUTOBRANE: Nonfluorinated membranes and PAN-H⁹ were identified: metallic bipolar plate as most representative. The planned duration of these projects is 5 years. This is the planned time for designing a solution.

Assessment of the required time for resolving the mapped problem is a result of this stage. Available information about ongoing research projects and development of new products are applicable at this stage. However, for both studies the discussed approach disclosed several engineering problems which were not considered by any R&D activities. It verified once again the advantages of a systemic approach for forecasting technological barriers.

⁹ Plan d'Action National sur l'Hydrogène et les Piles à Combustibles

Build the time diagram (timing)

At this stage a time diagram for the constructed network of problems (see Figure 5) is composed using results from a previous study. The time diagram can be considered as a technological roadmap for the explored technology on its way to market. Example of a resulting roadmap of problems (for low temperature small SFC) is presented in Figure 7.

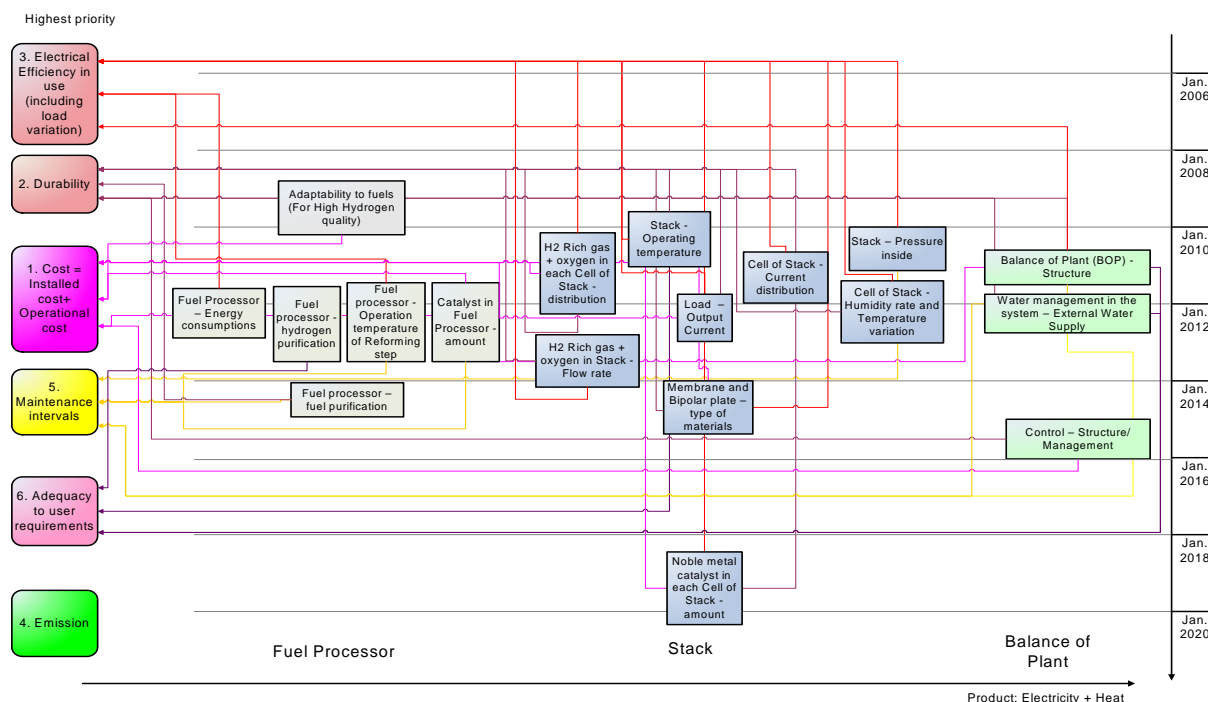

Figure 7. Map of problems for low temperature SFC on a time scale: technological context. (Information provided courtesy of EIFER, Karlsruhe (Gautier, L. et al., 2005))

Assessment of Technological Barriers

The advantage of problem maps with a time dimension (e.g. Figure 7) is that they forecast the technological future of the explored technology and monitor changes in the speed of evolution. At the same time it represents contradictions to be solved on the way to arriving at adequate values of critical-to-X features.

More than eight maps were constructed with timing just in the limits of the SFC study. One set of maps for low temperature SFC technology and another set for high temperature SFC. Each set included maps for technological, economic, environmental, and social contexts. Nevertheless, it should be noted that the presented maps were constructed on the basis of technological barriers, thus they mostly depict the engineering problems. Each box on the map portrays a specific technological barrier. Every problem-contradiction, in turn, can be decomposed and described as a set of sub-problems (contradictions) at different levels of detail.

Analysis and interpretation of the developed maps of technology barriers resulted in the following output:

- List of limiting resources linked with identified problems.
- Index of research projects which influence the advancement of the analysed technologies.
- Lists of top-priority projects for both SFC technologies.
- Time estimations when SFC technology can pass the "infant mortality" threshold.
- Level of maturity for competitive technologies according to identified critical-to-market features.
- Dynamics of changing the maturity level for competitive technologies within the studied forecast horizon.
- Qualitative models which can be updated while identifying better resources, available for R&D project (e.g. duration).

Assessment of technology barriers in the form of problem maps provides on the one hand a certain guideline for the future of the analysed technology and on the other hand it is flexible and adaptive enough to be useful for decision making even after its completion. Maps of contradictions can be applied to verify the quality of other forecasts. Some forecasts may be wrong as they do not take into account problems on the map which should be solved in the future.

Practical results of two forecast projects show that problem maps are much more reproducible in comparison with technological roadmaps (Kostoff & Schaller, 2001) since they are not influenced by professional preconceptions about existing solutions. Problem maps on a time scale (Figure 7) facilitate answering questions raised by the technological forecast What(?) technology (e.g. low or high temperature) When(?) in time (i.e. after answering problems) and Where(?) on the market (i.e. small stationary application in a region with necessary resources).

The results of the performed studies show a considerable capacity for future application of contradiction maps both for the assessment of technology barriers and for technological forecasting.

Perspectives of Problem-Contradiction Mapping

The ultimate test of the forecaster is an accurate and reliable forecast not the elegant or easily applied method.
T.Modis

Two studies into the future of new energy conversion technologies performed in the period from September 2004 to December 2006 using the concept of limited resource assessment showed valuable results on the level of the technology forecast as well as on the level of the forecasting process. The first study was concerned with small stationary fuel cell technology. The second study focussed on distributed energy generation technologies. According to the received feedback problem mapping and the assessment of limited resources, when integrated into the technology forecasting process, assist:

- in the assessment of technology barriers and opportunities in a bias-free way;

- in the accumulation of knowledge about limited resources in a structured way;
- in the recognition of the alternative pathways from present to future technologies independently from existing solutions.

There are different kinds of preconceptions due to different causes and human limitations. In the scope of the present paper we discuss only two kinds of prejudices: bias due to the unknown, and bias in existing knowledge. After close examination the second type of bias is a subset of the first one. The proposed approach contributes to the reduction of bias in existing knowledge due to system analysis and collaborative processing of expert knowledge. From a knowledge management viewpoint, the systematic approach with a given analysis grid using contradiction modelling, helps to focus on significant problems. It provides considerable support for handling the signal-noise problem and keeping the consistency of the forecast.

The proposed approach helps to discover new problems and organize knowledge in accordance with them. The resulting networks of problems accumulate and structure expert knowledge. Moreover construction of contradiction maps plays a part in reducing experts' bias.

From an inventive problem-solving viewpoint, assessment of technological barriers produces a holistic vision of problems from the surrounding super-systems and from sub-systems of the analysed technology. Previously invisible barriers are highlighted and specified. The resulting maps can be used to define the priorities in research and development programs. A systemic vision of technological barriers clarifies the key problems to be solved. As a result, interconnected problems can be reduced thanks to solving one key contradiction.

In practice, it was observed that constructing a network of contradictions helps members of the working team to increase their level of expertise quickly. This effect takes place as soon as knowledge acquisition is combined with developing the network. The process produces a system effect when experts are forced to study new limitations.

From a decision making viewpoint, the tested approach showed a better comprehension of stakes and links between technological advances and the market. A description of the limitations in the form of a timed network of contradictions brings a clear picture of challenges and time required. Resulting maps-networks for various emerging technologies are comparable and synthesize a lot of knowledge in a bias-free way.

Networks of contradictions can be applied for monitoring the evolution and rhythm of development of the targeted technology in the future. Development of the forecast, in close cooperation with forecasting specialists, researchers in emerging technologies and the customers of the forecast, provides credible results and supports development of customized methods.

The following remarks were collected during the performed studies.

- i. The proposed approach requires a high level of expertise and extends to the boundaries of available knowledge.
- ii. The proposed forecasting process takes a considerable amount of time and human resources to be performed properly.
- iii. Contradiction analysis is difficult to perform due to the specificity of contradiction models applied in OTSM-TRIZ. Experience in problem solving through contradiction analysis before beginning the forecasting is preferable.

- iv. The kind of problems-barriers (technical, social, economic, environmental) presented on the final maps depends entirely on the expertise and consistency of the working team.
- v. Definition of the objectives of the technology forecast and the scope of study should be done carefully and precisely before starting the study.
- vi. It is a complicated task to assess the limited resources for emerging and ongoing technologies in the framework of one project. Moreover, the procedures of assessment are many and varied.

There are also some remaining questions and remarks of which we have not got a clear understanding yet.

It became evident that by using just a technological context it is impossible to provide a reliable technology forecast. It is necessary to find a way of integrating knowledge and different models from economic, social, technological and environmental contexts. This issue becomes especially critical when forecasting new-to-the-world technologies in the framework of medium and long-term forecasts.

For instance, on the level of result interpretation there are problems of context consistency. For several contexts, the importance of different critical-to-X features can vary. Thus, for instance, time to market from a technological context can be predicted as January 2013, when in accordance with the social context, time to market can take a value of July 2015. How should one integrate the predictions from various contexts?

For medium and long-term forecasts faced with a fast-changing environment, the critical question is 'How should one manage the transformation from quantity to quality issues (a law of evolution known from dialectics¹⁰)?'

In this paper we present ongoing research. Whilst working towards the next generation of forecasting methods we aim to improve efficiency, transparency, and the length of time-horizons. Reliance on technology forecasting is unavoidable if we are to design the required solutions at the needed time in the needed place for real threats and opportunities rather than for probable or believable ones.

Acknowledgements

We wish to acknowledge the European Institute for Energy Research (EIFER), Karlsruhe for support of the research into technology forecasting. Among the members of EIFER, we greatly appreciate the assistance of Ludmila Gautier, and Mathieu Marrony. We also would like to thank our colleagues from the LICIA¹¹ team of LGECO, INSA Strasbourg for comments and discussions that helped to clarify many points presented in this paper.

¹⁰ The law of transformation of quantity into quality: "For our purpose, we could express this by saying that in nature, in a manner exactly fixed for each individual case, qualitative changes can only occur by the quantitative addition or subtraction of matter or motion (so-called energy)." [Engels' Dialectic of Nature. II. Dialectics. 1883]

¹¹ Equipe Ingénierie de Conception, Cognition, Intelligence Artificielle

References

- Altshuller, G. S. (1979). *Creativity as an Exact Science*. Moscow: Sovietskoe radio Publishing House. (in English: Altshuller, G. S. (1984). *Creativity as an Exact Science: The Theory of the Solution of Inventive Problems* (A. Williams, Trans.): Gordon and Breach Science Publishers.)
- Altshuller, G. S. (1991). *To Find an Idea: Introduction to the Theory of Inventive Problem Solving* (2nd ed.). Novosibirsk: Nauka. (in Russian)
- Armstrong, J. S. (1985). *Long Range Forecasting. From Crystal Ball to Computer*. (2nd ed.): John Wiley & Sons, Inc.
- Costa, O. D., Boden, M., & Friedewald, M. (2005). Science and Technology Roadmapping for Policy Intelligence – Lessons for Future Projects. *European Commission - JRC - IPTS 15*.
- Debecker, A., & Modis, T. (1994). Determination of the uncertainties in S-curve logistic fits *Technological Forecasting and Social Change*, 46(2), 153-173.
- Gautier, L., Marrony, M., & Kucharavy, D. (2005). Technological forecasting of Fuel Cells for small stationary applications. Karlsruhe: *European Institute for Energy Research - EIFER*. Report (No. HN-42/05/016).
- Khomenko, N., De Guio, R., Lelait, L., & Kaikov, I. (2007). A Framework for OTSM-TRIZ Based Computer Support to be used in Complex Problem Management. *International Journal of Computer Applications in Technology (IJCAT)*, In Press, Corrected Proof.
- Kostoff, R. N., & Schaller, R. R. (2001). Science and Technology Roadmaps. *IEEE Transactions on Engineering Management*, 48(2), 132-143.
- Kucharavy, D., & De Guio, R. (2005). Problems of Forecast, *In Proc. ETRIA TRIZ Future 2005*. pp. 219-235. Graz, Austria.
- Kucharavy, D., De Guio, R., Gautier, L., & Marrony, M. (2007). Problem Mapping for the Assessment of Technological Barriers in the Framework of Innovative Design, *16th International Conference on Engineering Design, ICED'07*. Paris, France: Ecole Centrale Paris.
- Llerena, P., & Schenk, E. (2005). Technology Policy and A-Synchronic Technologies: The Case of German High-Speed Trains. In P. Llerena & M. Matt (Eds.), *Innovation Policy in a Knowledge Based Economy* (pp. 115-134). Berlin: Springer.
- Meyer, P. S., Yung, J. W., & Ausubel, J. H. (1999). A Primer on Logistic Growth and Substitution: The Mathematics of the Loglet Lab Software. *Technological Forecasting and Social Change*, 61(3), 247-271.
- Modis, T. (2002). *Predictions - 10 Years Later*. Geneva, Switzerland: Growth Dynamics.
- Porter, A. L., & Group, T. F. A. M. W. (2004). Technology futures analysis: Toward integration of the field and new methods. *Technological Forecasting and Social Change*, 71, 287-303.
- Preez, G. T. d., & Pistorius, C. W. I. (1999). Technological Threat and Opportunity Assessment. *Technological Forecasting and Social Change*, 61(3), 215-234.
- Principles of Forecasting: A Handbook for Researchers and Practitioner* (1st ed.). (2002). Boston / Dordrecht / London: Kluwer Academic Publishers.
- Rogers, E. M. (2003). *Diffusion of Innovations* (5th ed.). New York: Free Press.
- Weisstein, E.W. Logistic Equation. (*MathWorld A Wolfram Web Resource*, 2003).
<http://mathworld.wolfram.com/LogisticEquation.html>