

Les cahiers du laboratoire Leibniz

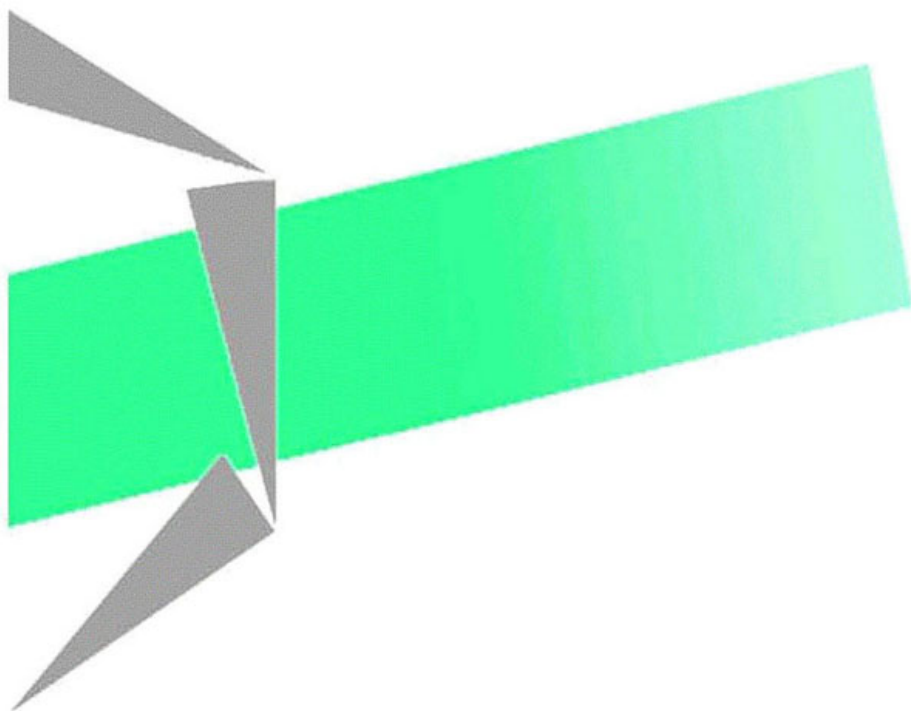

Kaleidoscope Convergence Workshop

Editors:
Ulrich Hoppe
Judith Schoonenboom
Mike Sharples
Barbara Wasson

Laboratoire Leibniz-IMAG, 46 av. Félix Viallet, 38000 GRENOBLE, France -
ISSN : 1298-020X

n° 159
Juin.. 2007

Selected Papers
from the
Kaleidoscope Convergence Workshop

December 4-6, 2006
Amsterdam, Netherlands

Editors:
Ulrich Hoppe
Judith Schoonenboom
Mike Sharples
Barbara Wasson

Content

1. Introduction	5
<i>The Convergence Workshop Task Force</i>	
2. A Method for Creating Collaborative Mobile Learning Trails.....	7
<i>Kevin Walker</i>	
3. COML (Classroom Orchestration Modelling Language) and Scenarios Designer : Toolsets to Facilitate Collaborative Learning in a One-to-One Technology Classroom.....	17
<i>Jitti Niramitranon, Mike Sharples, Chris Greenhalgh</i>	
4. Mobile Notes: Mobile Devices in Creative Discussions	25
<i>Lars Bollen, Guillermo Juarez, H. Ulrich Hoppe</i>	
5. CIEL: Integrating Approaches for Inquiry Learning.....	31
<i>Wouter van Joolingen</i>	
6. Collaborative Learning and Research Training: Towards a Doctoral Training Environment.....	38
<i>J. Bourdeau, F. Henri, A. Dufresne, J. Tchétagni, R. Ben Ali</i>	

Introduction

To foster synergy between research on collaborative, mobile and inquiry learning and between different scientific and methodological perspectives (namely, educational design, psychology and computer science) and to strengthen the cohesion of the community, the Kaleidoscope network has decided to organise a “Convergence Workshop” in conjunction with the 2006 Contractors' General Assembly in Amsterdam, Dec. 4-6.

The two fields of collaborative and inquiry learning have been represented in the network as Special Interest Groups from the beginning. Mobile learning was established more recently as an initiative. The three themes actually complement each other in that collaborative learning focuses on a general modality of learning which is not particularly related to a specific content or domain, whereas inquiry learning does indeed come with a specific domain focus in the areas of science, mathematics and technology. Mobile learning takes up the potential of a new generation of networked interactive and communicative devices. We thought this complementarity it would be a good precondition for synergy, but of course we also hope for wider synergies, e.g. with learning at work or AI in education, in the future.

In accordance with the idea of stimulating synergy in the network, workshop contributions were sought from within Kaleidoscope in the categories of *full paper* presentations, *young researcher* papers and *system demos* or interactive presentations. Integration of at least two of the three fields of technology enhanced learning as well as multiple methodological perspectives were required for each single paper to be accepted.

This collection comprises the five papers that have been selected for publication and for presentation at the workshop in a peer reviewing process. Two of the selected papers are in full paper category (Walker and Bourdeau et al.), one is a young researcher paper (Niramitranon et al.) and two describe system demos (van Joolingen and Bollen et al.).

We hope that these presentations at the Convergence Workshop will indeed promote integration and synergy between different lines of research and thus contribute to the advancement and sustainability of the Kaleidoscope network.

The Convergence Workshop Task Force

Ulrich Hoppe (co-chair, speaker),
Judith Schoonenboom (co-chair, local organiser),
Mike Sharples (co-chair),
Barbara Wasson (co-chair)

A Method for Creating Collaborative Mobile Learning Trails

Kevin Walker
London Knowledge Lab
k.walker@ioe.ac.uk

Abstract

In this paper I report results from recent trials in which students used mobile devices to collaboratively create, edit and share trails. These included 9- to 10-year-olds as well as adult diploma students, in the subject of horticulture in botanic gardens. Findings indicate that a narrow subject focus and a manageable amount of data capture are appropriate in most cases; trails are most effective when framed with structured tasks and a narrow focus. Structure can be introduced through the use of collaboration scripts that specify tasks, roles and groups.

Findings also show that audio is an important mode for communication and interpretation, particularly when paired with photos; audio alone is effective when location data is known; but photos alone are much less effective. Audio is especially effective when used collaboratively – for example when two people have a conversation or share their impressions while in front of the object or exhibit of interest.

Introduction

This research explores the use of mobile technology to create personalised learning trails, through the capture, editing and sharing of audio, photos and text during visits to museums, botanic gardens and other cultural heritage sites. This area of research was started by Peterson and Levene (2003) and developed in the Kaleidoscope project 'Personal and collaborative trails of digital and non-digital learning objects.' (<http://www.dcs.bbk.ac.uk/trails/>)

The core idea is that meaning is in the linkages between objects, not the individual objects themselves. Within the trails model, as it is developed so far, there are many possible variations – for example trails can be explicitly created about particular topics, or generated after the fact from data captured from random points of interest. Each point of interest in the real world is regarded as an 'analog learning object,' which, when captured, can be augmented with 'value added' information into a digital learning object. Learning objects are defined not according to a formal specification (such as IMS-LD) but very broadly to include almost anything; standardized data could be added automatically, but that is not

within the scope of the present research. In the trails model, meaning is made and knowledge is constructed by connecting these individual learning objects into a coherent – usually narrative – representation. This includes the steps of trail 'enactment' or capture, editing, reflection, and sharing – creating a circular process.

However, the theoretical trails work so far has focused on trails as the passive result of a learner moving through a knowledge space. My research seeks to add an explicitly constructionist element, so that learners actively create trails for other people; thus the trail serves not only as a process but as a learning product made comprehensible by the trail creator, and also as a 'tool for thinking' which prompts the creator to reflect on the task and the content to be collected.

This research is also informed by other research conducted in the Kaleidoscope network, specifically in the following activities:

- the Mobile Support for Integrated Learning project;
- the Mobile Learning in Informal Science Settings project;
- the Philosophy of Technology Enhanced Learning SIG (which has focused on mobile learning);
- The Kaleidoscope mobile learning initiative; and
- the Narrative and Learning Environments SIG.

My research is focused broadly in the area of science, with the following general research questions:

- Are digital learning trails effective for recording, analysing, interpreting and sharing data?
- Are digital learning trails an effective means for recording and testing hypotheses?
- How does the use of web-linked mobile technology change the process of the above activities?

While this is focused on a particular technological intervention, the focus is on the structure the entire activity system, which includes but is not limited to, the technology. That said however, the technology, in use, can change the activity, and even the nature of knowledge itself.

Methodology

In the trials described here, pictures, audio recordings and text are captured during a visit using a mobile phone. Using special software described below, the data are automatically uploaded to a web site where the captured trail can be edited, added to, and re-ordered in a way meaningful to the visitor. The trail can then be shared with others, as either an online or classroom presentation.

The captured data is analysed in relation to the task, and its relative quality in relation to the task. In addition, the trials were recorded with video, audio and photos, and this is treated as data - specifically footage and photos of students using conducting activities and using the system, and more importantly, students' conversations as they conducted the activities and used the system. This is augmented with interviews with the teachers, venue staff (in this case, educational coordinators at the botanic garden), other participating researchers, and the developers of the system, in order to attempt a comprehensive picture of the trials.

I have been collecting informal data from adult visits to museums since January 2006. An initial assumption was that automatic capture of location information would be important; in practice this appears to be irrelevant in many cases. For example in museums a thematic trail is more useful. In sites such as botanic gardens however, the location of particular plants, for example, can be important.

Focused trials began in June 2006. Four classes of school children aged nine to 10 visited Kew Gardens, a large botanic garden in London. Each class visit occurred on a different day. Each class was put into groups of four to five students, and each group given one mobile phone containing software enabling them to easily capture photos, audio and text, all of which was automatically sent to a web site.

This service is called My Art Space (<http://myartspace.org.uk>). It has been used in other UK museums and schools, and has been evaluated by the University of Birmingham. It has been approved as a tool for use with the UK national curriculum; for younger learners this is related to the skills of collecting and noticing, and for older ones, investigating and collecting evidence. It is assumed that teachers will structure visits and in so doing influence what students create. Further evaluations are taking place in Portsmouth, UK, in which students are creating trails for younger students to follow.

Using museum metaphors, learners capture 'objects' (in the form of photos, audio or text) which are automatically placed in a linear 'gallery' which provides a minimal structure for linking them together thematically. New objects can also be created at the site, and photos and audio files can be uploaded or copied from teachers' or other students' galleries. Galleries can be further customised somewhat with regard to colours and fonts.

This service was created especially for museums, and its broader use in botanic gardens and school field trips may require different types of representations of user data. In fact the service is currently being re-branded as 'Ookl' (an anagram of 'look') to fit this broader focus. For non-museum uses, however, the museum metaphors have been sufficient; though it was not created specifically with trail theory in mind, the representation of learner-collected data in linear (though editable) galleries makes it appropriate for studying learner-constructed trails. The results from this research, in turn, are generating

recommendations for further enhancements of the service. (I have no direct connection with the developers however, and the service is being used for research purposes only; the research is not restricted solely to this service.)

Learners can also 'collect' objects that the museum (or botanic garden in this case) has tagged with two-letter codes. When a learner selects 'Collect an object' on the phone and enters a code, the phone downloads information that the museum has entered for that object. This is meant to provide additional explanatory or contextualised information about museum objects on the phone.

Teachers can create their own galleries, and each class has its own 'store' containing all the objects created and collected by students, which they can all access. Students can copy teachers' or other students' objects to use in their own galleries; in such case this is made explicit and the student is asked to justify/explain why they are copying it.

Results: Initial data collection

Beginning in January 2006, adult visitors to museums were asked to record trails of objects or exhibits they visited, using text or audio recording. This proceeds from the hypothesis of Peterson and Levene (2003) that captured experience trails can support informal, lifelong learning. The data being collected is unstructured and informal, but indicates that unless framed with a specific focus and manageable scope, trails will not be used, much less used effectively, for learning. This finding concurs with Fritsch (2006) that museum visitors are more likely to create meaningful content when given discrete and focused tasks, not open-ended ones.

Another finding that emerged from this informal data was that location did not matter in many cases; what was important was the learning objects and the thematic links between them, not the geographic links. Related research by Nova et al (2005, 2006) shows that location was not important in other mobile contexts.

Results: School trials

In the trials with schools in June 2006 at Kew Gardens, the focus of the school visits was on food plants. Particular activities were devised before the technology was introduced – identifying the parts of a plant; sorting vegetables into plant parts; finding plants in the same family in the vegetable beds of the garden; and making up a drama, poem or riddle about a particular plant (without mentioning its name) for other groups to guess the plant. The first two activities were indoors, the others were in different parts of the garden.

The ability of My Art Space to add photos and text in addition to audio was thought to be important at a botanic garden – where images could help with plant identification for example. The 'collecting' capability of My Art Space would provide access to photos and data uploaded by the Gardens staff.

The four school classes collectively uploaded more than 700 individual objects. The collected objects for each group were plotted chronologically in a spreadsheet and classified by media type and whether task-related or not. [These spreadsheets can be included as an appendix if necessary; photos could also be included.] No attempt is made to quantitatively measure learning outcomes; the main goal has been to assess qualitatively how data was captured and used. Generally, students were able to easily use the technology in meaningful ways. There was concern by the Kew education staff that the technology might interfere with learning – a similar concern usually expressed by museums – but in fact, it was agreed afterward that this was not the case.

Overall the students loved using the phones as a tool for scientific investigation. There were a few cases in which boys tended to dominate the devices, but adults tried to ensure that everyone had a chance to use them. Each group of four to five students had one phone, and generally shared them around; in some cases a group delegated one student to record everything. One surprising finding was that the number of phones provided was deemed sufficient. If we had had enough phones we would have given one to every student, but the teachers said afterwards that such a 1:1 ratio of device to learner would have discouraged group work.

The audio recording facility proved – surprisingly – to be the most popular, and the most useful. Teachers praised the function because children could easily input information – especially those who might have difficulty in writing. Teachers and students also appreciated the fact this was a much quicker way of entering information than typing text – an important consideration in any mobile context.

Students used audio in different ways – sometimes individually recording their observations, sometimes conducting interviews with each other. Each audio clip could only be 15 seconds long, and students treated this limitation in one of two ways. Some students (especially girls) would carefully script and rehearse their recordings, while others (especially boys) would simply press record and if they didn't like the result, discard it and start again. Audio recordings had to be played back before uploading, and students were thankful for and amused by this function.

Audio was particularly effective when used collaboratively – for example when two people had a conversation or shared their impressions about a particular plant. Some students (especially girls) also interviewed each other. This form of journalistic inquiry appears

particularly effective in constructing trails for others to follow; preliminary data from another ongoing trial of My Art Space supports this.

Many pictures were taken – of other students, of vegetables, of other plants encountered and sometimes of information panels. Photos generally fall into four categories: those taken to record information for retrieval later; those taken merely to capture the experience of the day; those taken for use in constructing narratives; and miscellaneous – including tests of the camera and pure play. One teacher said she appreciated the ability to take photos because she would not have been able to provide enough digital cameras for the students.

The 'Collect an object' capability was used in the trials, with plants in each of the taxonomic families (carrots, tomatoes, mint, etc.) being tagged with information that could be downloaded. Both students and teachers particularly liked this function. The collected objects appeared in students' galleries.

Collecting is also a means of location tracking, since the location of tags is known. The tags were particularly useful in the outdoor activities; one activity had the students explicitly looking for individual plant traits among many unknown other plants, and the blue and white tags were much easier to look for than particular traits; most children are unused to identifying plants because plant science in schools can be very limited. Additionally, tags made it easier for children to share the location of plants.

Students learned very quickly how to use the mobile phones. There were some inevitable technical problems, with the software sometimes logging out unexpectedly for example. Generally the software is simple to use and there is no easy way for students to access the phone's other capabilities (the phones were restricted from making calls and sending text messages). At the start of one day, a student asked me how to take pictures; before I could answer, one of his classmates grabbed the phone and showed him.

Each time an object is captured it is uploaded, which can take up to 30 seconds; the developers have already planned to make the uploading occur in the background. A related issue is that everything captured cannot be accessed again on the phone, only on the web site. In the drama activity, students captured data as part of research to be used again later that day, but could not access it from the phones.

Both students and teachers wanted to record video, or at least audio together with photos (currently an 'object' is comprised of only a photo or audio clip). To my knowledge no one asked about the ability to communicate with other students over the phone or access others' data, but this capability has been suggested by the developers. It may be useful in collaboration scripts (discussed below).

Results: Adult trial

In September 2006 a trial was conducted at Kew Gardens with 13 adult students studying for a Diploma in Botanical Horticulture. These students were from a very diverse range of countries representing Africa, Asia and Europe.

I designed a task to exploit this broad cultural experience, and also to address the shortcomings of the previous trials and lessons learned. With the focus on food plants as before, students were asked to visit the vegetable beds, choose 6 to 8 plants, and for each, record one photo and one audio clip which was a conversation about how they used that plant in their home country. This did not proceed from an existing CSCL script, but falls into the general class of 'shared regulation scripts' identified by Stegmann et al (2004) in which learners plan, monitor and regulate their own cognition, motivation, behaviour and context.

Since the goal of the diploma course is to enable students to effectively deliver education programmes in their own countries, this trial was not designed to teach an aspect of botany but to act as a 'tool for thinking' to help them reflect on the process of creating their own educational materials for visitors. As such, the product they were asked to create was a multimedia tour for visitors, focusing on food plants.

The 'collecting' function was not used, but it was explained that at each stop, visitors would be able to download the content that the students were creating.

The students worked in pairs, with one phone per pair. This was intended to exploit the benefits of conversations observed in the previous trials. Since each diploma student was from a different country, this also provided each pair with two diverse sets of cultural knowledge.

The students spent one hour in the vegetable beds recording data, then one hour in the garden's computer lab editing their trails. The trails were then presented by each pair to the rest of the class. Trail editing and sharing steps were explicitly included to address a major shortcoming of the previous trials – that captured data was not revisited by the classes after their visit. Although the captured data in the previous trials was plentiful and substantive, it was not possible to plan for the successive editing and sharing steps. Thus in the adult trial the editing and sharing was to be done at Kew Gardens, directly following capture.

Collectively the students created a total of 101 objects. Though the focus of the task was quite narrow, the pairs were creative in constructing the resulting trails. For example, one

group themed their trail as 'making a salad,' while another focused not on food-related uses of the plants but on medicinal uses in each country.

The structure of the task – specifying one photo and one audio clip for each plant – addressed the problem of decontextualised objects resulting from the previous trial. A trail which is merely captured but not revisited and edited simply does not make much sense without some additional interpretation. The My Art Space system allows learners to enter text when they capture a photo, but this facility was used for only a handful of the hundreds of photos uploaded in the school trials. Although the photos and audio recorded in the adult trial appeared as separate 'objects' (a shortcoming of the My Art Space system), the student pairs were able, in the editing process, to ensure that they were at least placed in the right sequence. More importantly, a great deal of text information was added to each photo during the editing process; some pairs augmented this information with internet searches, and one even added Latin names of the plants. The resulting trails are generally coherent and stand alone as narrative threads.

Discussion and next steps

Research in cognitive psychology (Moreno and Valdez, 2005; Mayer and Moreno, 2000) shows that audio is a more effective mode than text for delivering information related to a visual object under study. Smith et al (2004) have shown the effectiveness of museum audio tours in this regard. The present research suggests its effectiveness not only for delivery but also as a constructive tool for learning – particularly in collaborative situations. The value of conversations is well known in museum learning (Allen 2002; Leinhardt et al, 2002; Hensel, 1987). In mobile learning specifically, learning is perceived as being as much about conversations as content (Sharples, 2005; Taylor, 2003). This could be seen directly in the Kew Gardens trials in the students' recorded conversations.

Gibbons (2006) says that the problem of learning objects is not a matter of finding and sequencing them, "but it is really a problem of *the instantaneous computational design of a conversation* intended to support learning through different types of events that accomplish story-telling in which the learner participates" (his emphasis). "Every bit of information in an instructional communication," he says, "is really just a new brush stroke on a larger painting of a system that is in progress." Just as a painting tells story, he says, so does a 'system', and the goal of education is to bring learners into the process of storytelling; learners' stories tell how much they know about the 'system' under study. By 'systems' Gibbons refers mainly to cause-effect systems – of which botany is a good example.

The trails created by the 9-year-olds were structured only by questions on printed worksheets prepared by teachers, which were not directly related to the mobile phone technology introduced. The most relevant data uploaded in those trials appears to have

come from planned and self-structured collaboration within groups. Such collaboration could be further structured to stimulate productive interactions through the use of scripting. Kobbe et al (2003) have detailed the specification and standardization of such collaboration scripts, and they have been used in mobile contexts (see Stegmann, 2004).

Journalistic inquiry appears to be effective not only as a method but as a product of the trail capture, editing and sharing process. Future trials may frame tasks in terms of news stories or audio podcasts to be created and shared. A traditional journalistic approach utilises structured interviews to collect multiple viewpoints on a given topic, and frames a product as a structured narrative in an 'inverted pyramid' style in which the most important 'who, what, where, when, why, how' information is given at the start. A collaboration script may support this process by assigning roles to students (interviewer, interviewee, writer, researcher, fact-checker, editor); and by structuring tasks (interviewing, researching in a library or online, editing, etc.). This could be derived from a 'jigsaw' script in which different roles are assigned different parts of a larger 'picture' and must work together to put the pieces together. (Aronson et al, 1978)

The 'collecting' facility in My Art Space could be used not just for downloading relevant object data, but can pose questions, or specify scripted tasks or roles at each tagged location. The tagging ability also can act as a form of location tracking, since the locations of tags is known; if 'collecting' is used at each step in the trail, this results in a trail of physical locations as well as of subject-specific data. In sites where location is relevant for learning, this would conform more closely to Peterson and Levene's (2003) original trail theory.

Future work is expected to study the technology in relation to learners' formulation and testing of scientific hypotheses, specifically in the area of physics.

References

- Allen, S. (2002) Looking for learning in visitor talk: A methodological exploration. In Leinhardt et al (Eds.) *Learning Conversations in Museums*. London: Erlbaum.
- Aronson, E., Blaney, N., Stephan, C., Sikes, J. & Snapp, M. (1978). *The Jigsaw Classroom*. Beverly Hills, CA: Sage Publications, Inc..
- Fritsch, J. (2006) (Visitor studies, V&A Museum, London) Personal communication, February 2006.
- Gibbons, A.S. (2006) The interplay of learning objects and design architectures. *Educational Technology* Jan-Feb 2006, 18-21.
- Hensel, K. (1987) *Families in a museum: Interactions and conversations at displays*. Ph.D. dissertation, Columbia University Teachers College.

- Kobbe, L., Weinberger, A., Dillenbourg, P., Harrer, A., Hämäläinen, R. & Fischer, F. (2006) Specifying Collaboration Scripts (submitted).
- Leinhardt, G., Crowley, K. and Knutson, K. (2002) *Learning Conversations in Museums*. London: Erlbaum.
- Moreno, R. & Mayer, R. E. (2000). A learner-centered approach to multimedia explanations: Deriving instructional design principles from cognitive theory. *Interactive Multimedia Electronic Journal of Computer Enhanced Learning*, <http://imej.wfu.edu>.
- Moreno, R., & Valdez, F. (in press). Cognitive load and learning effects of having students organize pictures and words in multimedia environments: The role of student interactivity and feedback. *Educational Technology Research and Development*.
- Nova, N., Girardin, F. & Dillenbourg, P. (2006) The Underwhelming Effects of Automatic Location-Awareness on Collaboration in a Pervasive Game, *International Conference on the Design of Cooperative Systems* (May 9-12, 2006, Carry-le-Rouet, Provence, France).
- Nova, N., Girardin, F. and Dillenbourg, P. (2005) 'Location is not enough!': an Empirical Study of Location-Awareness in Mobile Collaboration. *Proceedings of Wireless and Mobile Technologies in Education*, Japan, 2005.
- Peterson, D. and Levene, M. (2003) Trail records and navigational learning. *London Review of Education* 1(3).
- Sharpley, M. (2005) Learning as conversation: Transforming education in the mobile age. *Seeing, Understanding, Learning in the Mobile Age*, 28-30 April, Budapest.
- Smith, J.K., Waszkielewicz, I., Potts, K. and Smith, B.K. (2004) Visitors and the audio program: An investigation into the impact of the audio guide program at the Whitney Museum of American Art. Unpublished internal report.
- Stegmann, K. (2004) Examples of CSCL scripts using mobile tools. Deliverable of the Kaleidoscope project Mobile Support for Integrated Learning. Available at <http://www.iwm-kmrc.de/cossicle/resources/D23-03-01-F.pdf>
- Taylor, J. (2003) 'A task-centred approach to evaluating a mobile learning environment for pedagogical soundness. *MLEARN2003* conference, London, May 19-20, 2003.

COML (Classroom Orchestration Modelling Language) and Scenarios Designer: Toolsets to Facilitate Collaborative Learning in a One-to-One Technology Classroom

Jitti Niramitranon, Mike Sharples, Chris Greenhalgh
Learning Science Research Institute (LSRI)
University of Nottingham
{ttxjn3, Mike.Sharples}@nottingham.ac.uk, c.greenhalgh@cs.nott.ac.uk

ABSTRACT

In a one-to-one collaborative learning classroom supported by ubiquitous computing, teachers require tools that allow them to design of learning scenarios, and to manage and monitor the activities happening in the classroom. Our project proposes an architecture for a classroom management system and a scenarios designer tool, both based on a Classroom Orchestration Modelling Language (COML), to support these requirements. We are developing and testing this with the GroupScribbles software using a set of learning scenarios for classrooms equipped with pen tablet computers.

Keywords

Collaborative and group learning; Learning systems platforms and architectures; learning design, wireless and mobile technologies

1. INTRODUCTION

The emergence of one-to-one technology (one computer device or more per student) has the potential to enhance learning in the classroom [1]. A literature survey reveals two main areas of interest. The first is based on a pedagogical approach, with a focus on the study of possible patterns in face-to-face classroom activity. The aim is to capture and describe common learning situations, particularly for collaborative learning [2] [3] [4]. The other area is focused on the technology and is concerned with creating innovative software and hardware tools that will be able to enhance specific learning scenarios [5] [6] [7]. A key problem with this research is how to balance the pedagogical and computational approaches, so that technologies for classroom interaction can support effective collaboration in real classrooms [8]. On one hand, teachers should be easily able to design and manage collaborative learning supported by ubiquitous computing (such as a combination of tablet PCs, desktop PCs and electronic whiteboards). On the other hand, the computational system, including hardware and software technologies should be able to support a range of effective learning scenarios. This paper proposes to design a Classroom Orchestration Modelling Language (COML) and a scenario designer tool, with the aim of providing a single platform that brings together the pedagogical and technological aims we have highlighted.

2. PROPOSED DESIGN AND ARCHITECTURE

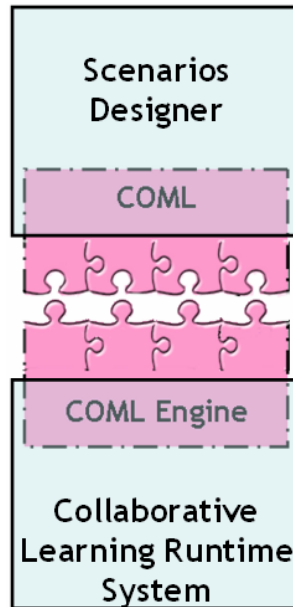

Figure 1: Design Architecture with 3 additional proposed components, Scenarios Designer, COML and COML engine

As seen in **Figure 1**, the architecture of the system has been divided into two major parts, the Scenarios Designer and collaborative runtime system. These are integrated by the use of a common COML definition of the learning scenario, as supported by the COML constructor on the scenarios designer side and a COML execution engine on the runtime system side.

The Scenarios Designer has been developed through the study of pre-existing scenarios for effective interactive learning in the classroom. These scenarios were analysed to capture common components such as actors, learning materials, technical and non-technical related activities, which were then defined as elements of the formal notation. A sequence of prototyping has produced a software system that supports notations for interactive learning design, including actors and learning artefacts. These components can then be combined into activity diagrams that cover the original scenarios (with iterative refinement as required). The real value of these learning diagrams is that they can be exported as a COML document to be executed by the computer supported collaborative learning *run-time* system. COML is based on generic XML description with similar aims to CML [9] (although CML is currently only a conceptual design rather than an actual technology). The

COML engine manages the interaction of a teacher and learners with ubiquitous computing in a classroom guided by the COML scenario definition.

3. LEARNING SCENARIO AND SCENARIOS DESIGNER TOOL

The screenshot displays the Scenarios Designer tool interface. At the top, there is a menu bar with 'New', 'Open', and 'Save' buttons, and a 'Designer Tools Bar' with a red arrow pointing to the 'Deliver' column header. Below the menu bar is a table with columns: 'Actors', 'Deliver', 'What to do?', 'Receiver', 'Electronic Resources', and 'Presentation Spaces'. The table contains seven rows of scenario steps, numbered 1 to 7. A red box highlights the 'Actors' column, and a red arrow points from it to the 'Component Properties' box on the left. The 'Component Properties' box contains fields for 'Scenario Name' (Chemical Formula Game), 'Scenario Description' (1. Students answer the abbreviation of elements, 2. Students draw), and 'How many groups in the class?' (3 groups). Below this box is a red arrow pointing to the text 'Components Properties'. The 'COML Document' window at the bottom shows XML code for the scenario, with a red arrow pointing from the 'Component Properties' box to it. The text 'Design Space' is written in pink over the table's 'Electronic Resources' column.

Actors	Deliver	What to do?	Receiver	Electronic Resources	Presentation Spaces
Teacher, Students	Teacher	Q Give the abbreviation for each element	Class	Chemical_Element.JPG	Public 1
Groups, Presenters	Class	A Answer Step 1	Teacher	T Text [In Class]	Public 1
Question?, Answer, Discussion, Other	Teacher	Q Draw H2O	Group 1	T H2O	Group 1
Text, File, Drawing, Any	Teacher	Q Draw CO2	Group 2	T CO2	Group 2
Scenario Name: Chemical Formula Game	Teacher	Q Draw N2O	Group 3	T N2O	Group 3
Scenario Description: 1. Students answer the abbreviation of elements, 2. Students draw	Group 1, 2, 3	A Answer Step 3, 4, 5	Teacher	Drawing [In Class]	Public (Group 1, 2, 3)
How many groups in the class?: 3 groups	Teacher	D Conclusion	Class	T Any [In Class]	Public (Conclusion)

```

<coml ver="1.0">
  <Scenario name="Chemical Formula Game">
    <Description>
      1. Students answer the abbreviation of elements
      2. Students draw molecular
    </Description>
    <Step No="1">
      <Name>Question</Name>
      <Description>This step is to ask for a whole class</Description>
      <Deliver Type="teacher"/>
      <Activity Type="question">
        <Topic>Give the abbreviation for each element</Topic>
        <Memo>Start with the first three row on the table</Memo>
      </Activity>
    </Step No="1">
  </Scenario>
</coml>
  
```

Figure 2 : Screen shot of the Scenarios Designer and COML document

The current version of the Scenarios Designer has four main parts: a designer toolbar, a components properties box, a working space and a COML document window which is resizable. On the designer toolbar, common components captured from the scenario

analysis process are listed, which have been divided into three sets: actors, activities and learning artefacts. Actors have four different roles: teacher, students, groups and presenters (the computational actors that present the learning artefacts on spaces such as a display screen). The activities have four components: question, answer, discussion, other (user defined). The learning artefacts comprise four types of electronic resource: text, file, drawing and any, where all of these are data to be presented in particular presentation spaces such as a computer screen.

To create a learning scenarios, a teacher drags components from the designer tool bar and drops them onto the appropriate blocks in five 'swim lanes': deliverer, what to do?, receiver, electronic resources, and presentation space. Once any component is placed in the working area, the COML interpreter engine, which is running in the background of the Scenarios Designer, will convert the diagram into the COML document corresponding to the designed diagram.

As an example, we show three main learning scenarios running in order: brainstorming, followed by group work, followed by conclusion. The brainstorming scenario begins with a teacher showing the picture of an abbreviated name of some chemical elements to all students and then asking students as a whole class for the full name of each element. In the next scenario, the students are formed into three groups and the teacher gives each group a chemical formula. The teacher then asks them to draw the correct molecular relation corresponding to the given question. The teacher concludes by discussing the results of the group activity with the whole class.

Therefore, the meaning of the scenario design pictured in Erreur ! Source du renvoi introuvable. from the first to the seventh row can be interpreted as the following

- 1st row: a teacher shows a "prepared file (Chemical_Element.JPG)" which is a chemical element table to "all students in the class" on the public presentation space (such as an electronic whiteboard) named "Public 1" and asks students verbally to "please answer with the correct abbreviation for each element";
- 2nd row: all students answer the teacher by typing "text" on their personal computing device and the all answers are then shown on the presentation space "Public 1";
- 3rd row: the "teacher" splits the students into three groups and verbally asks the "group 1" to draw a molecular form of H₂O. The prepared question "H₂O" which was created by using "text tool" is also displayed on the presentation space of "Group 1" (an environment for "group 1" to work collaboratively);
- 4th the "teacher" verbally asks the "group 2" to draw a molecular form of CO₂. The prepared question "CO₂" which was created by using "text tool" is also displayed on the presentation space of "Group 2" (an environment for "group 2" to work collaboratively);
- 5th the "teacher" verbally asks the "group 3" to draw a molecular form of N₂O. The prepared question "N₂O" which was created by using "text tool" is also displayed on

the presentation space of “Group 3” (an environment for “group 3” to work collaboratively);

- 6th group 1, 2 and 3 reply to the teacher with “drawing tool in the class” and all answers are displayed on the public space named “Group 1, 2, 3”;

- 7th the teacher has a conclusion session to “all students” and also allows students use “any tools (text, file or drawing)” on the public space named “Conclusion”.

The Scenarios Designer is able to identify the actor(s) who will be in charge of creating or completing each certain task and to specify the flow direction of the tasks from one to another actor (e.g. from a teacher to all students or from group A to groups B). These design techniques have made the Scenario Designer different from LAMS [10] whose design is based on the concept of the tasks stepping forward through available tools provided by LAMS itself, for example, from chatroom to vote and then from vote to question(s) and answer(s).

4. COML, COML ENGINE AND RUNTIME SYSTEM

Although COML has a similar basic learning design model to EML [2], that is “*Role performs Activities within an Environment*”, the main idea underlying COML is derived from trends in the field of collaborative learning supported by one-to-one technology and distributed system runtime environment. COML therefore has begun with its own language structure and specification.

As our test bed for this research we are using an existing distributed system for collaborative learning called GroupScribbles (GS) [11] as the runtime system. In order to make GS understand and work in coordination with COML, a COML engine is being developed which works as an interpreter and interface between COML and GS. The COML engine is able to call all GS functions to prepare the designed lesson ready for the class.

```

<coml ver="1.0">
  <Scenario name="Chemical Formula Game">
    <Description>
      1. Students answer the abbreviation of elements
      2. Students draw molecular
    </Description>
    <Step No="1">
      <Name>Question</Name>
      <Description>This step is to ask for a whole class</Description>
      <Deliver Type="teacher"/>
      <Activity Type="question">
        <Topic>Give the abbreviation for each element</Topic>
        <Memo>Start with the first three row on the table</Memo>
      </Activity>
      <Receiver Type="student"/>
      <Resource Type="file" Name="chemical_element.JPG"/>
      <Presentation Type="Public" name="Public 1"/>
    </Step>
  </Scenario>
</coml>

```

Figure 3: Sample of COML document for the first step of Brainstorming scenario

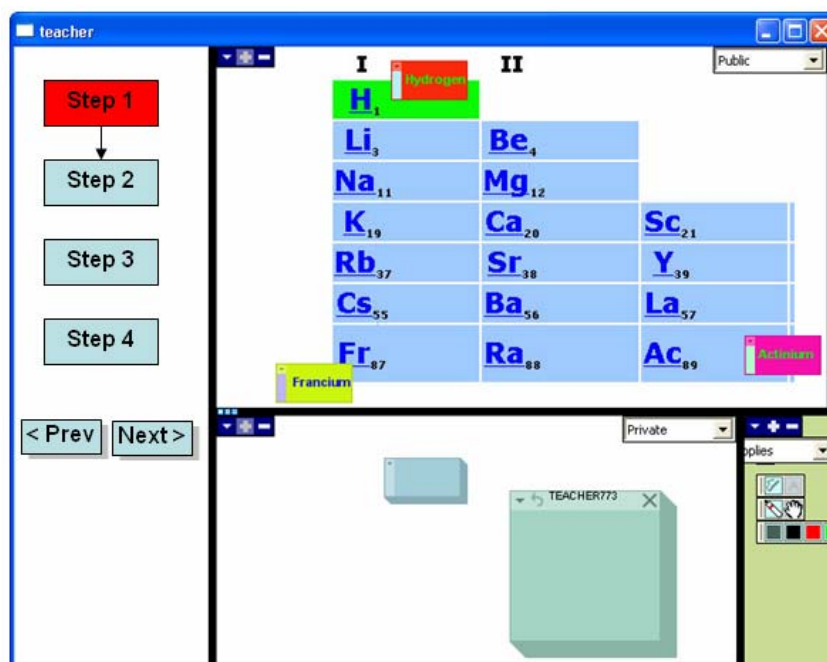

Figure 4: A design of GS when it works together with COML engine

In the example scenario, teachers display chemical elements and verbally ask students “What are the full names of these chemical elements?” This step uses a COML document which is generated by Scenarios Designer as shown in

Figure 3. Once the COML document is parsed and interpreted by the COML engine it loads the prepared picture onto the GS public space as shown in **Figure 4**. We can regard the COML engine as an actor that prepares the technical learning environment, and monitors, controls and gives relevant information to the teacher so that they know when to transition to subsequent stages of the learning scenario.

5. CONCLUSIONS

We are currently developing and refining the Scenarios Designer with Macromedia Flash, the COML definition based on XML schema, the COML engine and some additional functions in GS based on Java technology with the aim of balancing pedagogical and computational orientations. Our goals are to:

- allow teachers design or prepare the lessons beforehand
- enable monitoring, tracking of learning activities/sequences and transition changing
- potentially make the designed scenarios exchangeable in a collaborative learning object format, so that teachers can share lesson elements.

The system will be evaluated in the lab and through teacher walk-throughs and interviews to explore whether these tools are supporting the research aims.

6. ACKNOWLEDGEMENTS

The authors wish to thank SRI international and GS design team: John Brecht, Jeremy Roschelle, and Patti Schank for the many fruitful discussions and ideas they have shared including the offer of the GroupScribbles software to be used as a runtime system in this research.

REFERENCES

- [1] Chan, T.W., Roschelle, J., Hsi, S., Kinshuk, Sharples, M., and Brown, T. (2006). One-to-one technology enhanced learning: and opportunity for global research collaboration. *Research and Practice in Technology Enhanced Learning* 1(1): 3-29.
- [2] Koper, R. and Manderveld, J. (2004). Educational modelling language: modelling reusable, interoperable, rich and personalised units of learning. *British Journal of Educational Technology* 35(5): 537-551.
- [3] Chris DiGiano, L.Y., Charlie Patton, Jeremy Roschelle, Deborah Tatar, Matt Manley (2003). Conceptual Tools for Planning for The Wireless Classroom. *Journal of Computer Assisted Learning* 19(3): 284.
- [4] Roschelle, J., Schank, P., Brecht, J., Tatar, D., and Chaudhury, S.R. (2005). From Response Systems to Distributed Systems for Enhanced Collaborative Learning. In *Proceeding of the 13th International Conference on Computers in Education (ICCE 2005)*: 363-370.

- [5] Liu, T.C., Wang, H.Y., Liang, J.K., Chan, T.W., Ko, H.W., and Yang, J.C. (2003). Wireless and mobile technologies to enhance teaching and learning. *Journal of Computer Assisted Learning* 19(3): 371-382.
- [6] Pinkwart, N., Hoppe, U., Milrad, M., and Perez, J. (2003). Architectures and educational scenarios for cooperative use of PDAs in wireless networks. *Journal of Computer Assisted Learning* 19(3): 383-391.
- [7] Liu, T.-C., Liang, J.-K., Wang, H.-Y., and Chan, T.-W. (2003). The Features and Potential of Interactive Response System. In *Proceeding of the International Conference on Computers in Education (ICCE)*: 315-322.
- [8] Sharples, M. (2000). The design of personal mobile technologies for lifelong learning. *Computer & Education* 34(3-4): 177-193.
- [9] Brecht, J., Chung, M., and Pea, R. (2002). CML - The ClassSync Modeling Language, *Presented at the Computer Support for Collaborative Learning (CSCL) conference, Boulder, CO*. Retrieved 28th November, 2005, from www.stanford.edu/~roypea/RoyPDF%20folder/A108_Brecht_etal_02.pdf
- [10] Dalziel, J. (2003). Implementing Learning Design: The Learning Activity Management System (LAMS). In *Proceeding of the 20th Annual Conference of the Australasian Society for Computers in Learning in Tertiary Education (ASCILITE)*, Adelaide, 7-10 December 2003. Retrieved 26th January, 2006, from <http://www.ascilite.org.au/conferences/adelaide03/docs/pdf/593.pdf>
- [11] Patton, C. and Schank, P. (2006). Group Scribbles Innovation Flyer. *To be submitted to Popular Science Best of What's New 2006*.

Mobile Notes: Mobile Devices in Creative Discussions

Lars Bollen, Guillermo Juarez, H.U Hoppe
COLLIDE Research Group
University of Duisburg-Essen, Germany
{bollen@collide.info}

Introduction

The trendy notion of “mobile learning” has different connotations: On the one hand, it can be understood as “learning on the move” – often referred to as “learning any time anywhere”. Of course this interpretation relies on specific kinds of technological enabling, but the definition aims at the general setting of learning activities. Particularly, it includes informal learning settings (cf. [1]). A second interpretation sees mobile learning somewhat more pragmatically as learning with mobile devices. This may include formal learning in the classroom. Here, mobile devices may enable a one-to-one orchestration with learning devices (one device per learner, cf. [2]).

This workshop contribution clearly bases on the second view in that it explores the use of mobile devices in classrooms. The one-to-one assumption (see above) raises a couple of questions which need more exploration. Among these are the questions of ownership (*who owns the personal device – the institution or the student?*) and homogeneity (*will one device be used throughout different subject matters?*).

In this context, we explore device heterogeneity even in one specific setting. This setting includes personal mobile devices (PDAs) as well as a publicly visible interactive screen connected to a PC. Similar mixed device scenarios involving tablet PCs and bigger interactive screens have been studied by Liu and Kao [3].

Based on the findings of Liu and Kao, we believe that, as a next step, dedicated classroom scenarios with heterogeneous devices should be designed and orchestrated. Here, “dedicated” means an orientation towards specific types of learning activities in which different types of devices would be integrated based on different functional assignments. Evidently, the functional assignments should reflect the specific strengths and potential complementarities of the different devices. E.g., following Liu and Kao [3], public interactive displays complement the lack of shared visual focus with smaller personal devices.

In our own previous work, we have explored extending collaborative visual modelling tools to PDAs [4]. In one “light weight” version, we used PDAs to graphically annotate models without replicating the functionality (or “operational semantics”) of the modelling environment on the PDAs. The fully fledged modelling environment would run on a PC and would be shown on a large interactive display. On the PDA, an area of the visual modelling space could be selected and annotated using and hand writing and drawing. These annotations were directly transferred to the public display. This type of interoperability could be characterised as synchronous bitmap sharing with graphical

annotation. But this usage scenario also suffers from a problem of shared visual focus, due to the necessary switching between the PDA view and the public view. It is also somewhat clumsy to adjust the viewing area on the PDA. This environment decreases the problem of switching focus from the PDA to a shared display area, since here the PDA is only used as an input device; upcoming discussions are still conducted with the help of a large, shared display.

In this contribution, we focus on an application in which the function of PDAs is more limited but more focussed: The PDAs are used as as input devices in a quasi-synchronous mode. The usage scenario is a face-to-face brainstorming discussion in which contributions are prepared on the participants' PDAs. When a contribution (either text based or a hand written sketch) is completed, it is sent to a database from which it can be retrieved and transferred to the public display application. The transfer of a contribution to a public display is done either instantaneous (synchronous) or it can be selectively controlled by a discussion moderator, in which case the transmission would be delayed and asynchronously. All public discussions would only refer to the public display area.

Mobile Notes

Building on the conceptual background described in the previous section, we designed and implemented an application to support classroom discussions with mobile devices and electronic whiteboards similar to what has been presented in [5] and [6].

The environment - we called it "Mobile Notes" – is based on FreeStyler [7] and Cool Modes [8][9], two applications that have been developed at the University Duisburg-Essen. These applications support interactive and collaborative modelling with heterogeneous semantics (e.g., Petri Nets and concept maps) in computer supported classroom scenarios. Mobile Notes' main functionality is to use PDAs to write short textual contributions, to draw sketches or to participate in a vote and submit these products to a central server in order to display and arrange them on an electronic whiteboard and to initiate further discussions and collaboration.

Mobile Notes' main components are:

- A computer running FreeStyler with the Mobile Notes plug-in (the server).
- Mobile devices acting as input clients.
- A database as communication interface between the clients and the server.
- An interactive whiteboard used as the common output device for all the clients. This board is based on the FreeStyler application.

Figure 5 shows a typical arrangement of these components.

Following the concept of functional assignments (see above), the mobile devices is designed *not* to copy or emulate what is shown on the screen. Being aware of the limitations as small screens and the lack of conventional input devices as full size keyboards, our approach was to develop a custom interface that enables an easy interaction between user and system.

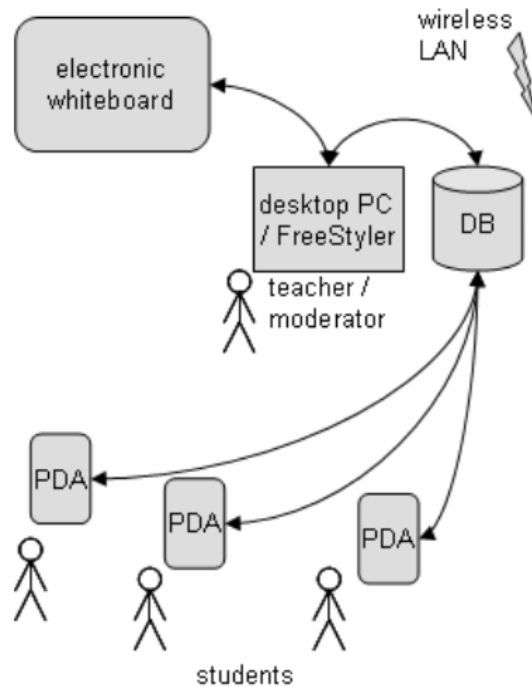

Figure 5. Typical arrangement of Mobile Notes' components

Typical use cases for this architecture are e.g. teacher presentations with comments from the audience, brainstorming scenarios with participants freely collecting ideas and comments or test questions, that are prepared by a teacher / moderator that have to be answered by students.

Figure 6 and Figure 7 show a handwritten annotation in the PDA and its representation in FreeStyler and a typical FreeStyler workspace during a Mobile Notes session. This screenshot originates from a recent usage of Mobile Notes during the “Big Issues in Mobile Learning Workshop” in Nottingham, UK, in June 2006.

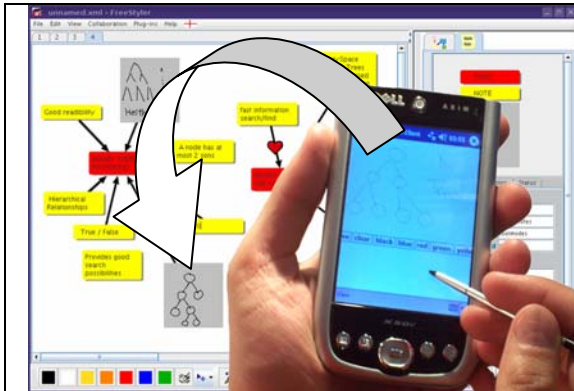

Figure 6. Creating handwritten notes and sketches for use in FreeStyler

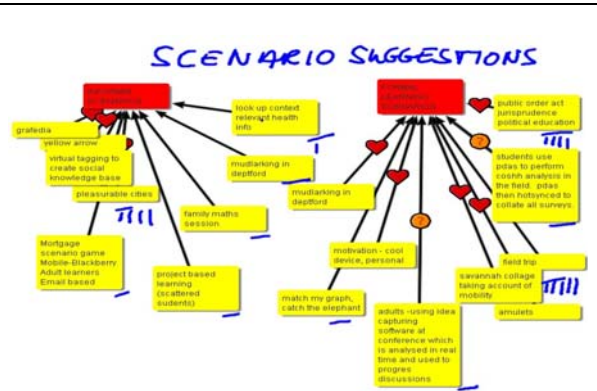

Figure 7. Screenshot of a Mobile Notes workspace

System Demo

The envisioned system demo consists of an interactive and productive discussion between the workshop participants while using the hardware and software described above. Figure 8 shows a situation similar to what is planned for the system demo.

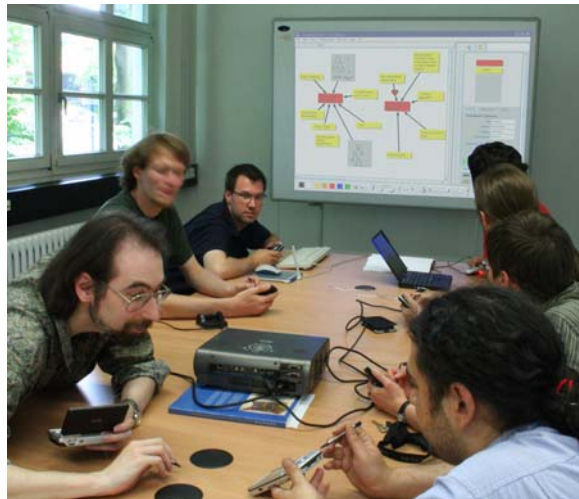

Figure 8. Using Mobile Notes in a discussion.

For this purpose, we will bring several (5-7) PDAs and a laptop to the workshop. Participants will be able to use the PDAs in a moderated discussion as input devices. The laptop will be used by the moderator to run a discussion support application (FreeStyler). We will need a video projection to be connected to the moderator's notebook.

Additionally, we will need an open wireless network. If a wireless network is not available, we could bring our own access point.

References

- [1] E. Scanlon, A. Jones and J. Waycott, Mobile technologies: prospects for their use in learning in informal science settings. *Journal of Interactive Media in Education* (Portable Learning: Experiences with Mobile Devices. Special Issue), 2005/25.111.
- [2] T. Chan, J. Roschelle, S. Hsi, Kinshuk, M. Sharples, T. Brown, C. Patton, J. Cherniavsky, R. Pea, C. Norris, E. Soloway, N. Balacheff, M. Scardamalia, P. Dillenbourg, C. Looi, M. Milrad and U. Hoppe, One-to-one technology-enhanced learning: An opportunity for global research collaboration. *Research and Practice in Technology Enhanced Learning*, 1(1), 3-29, 2006.
- [3] C. Liu and L. Kao, Handheld Devices with Large Shared Display Groupware: Tools to Facilitate Group Communication in One-to-One Collaborative Learning Activities. In *Proceedings of the 3rd IEEE Workshop on WMTE*, pp. 128-135, 2005.
- [4] N. Pinkwart, C. Schäfer and U. Hoppe, Lightweight Extensions of Collaborative Modeling Systems for Synchronous Use on PDA's. In *Proceedings of IEEE International Workshop on WMTE*, pp 125-129, 2002.
- [5] L. Bollen, S. Eimler and H.U. Hoppe, SMS-Based Discussions – Technology Enhanced Collaboration for a Literature Course. In *Proceedings of the 2nd IEEE Workshop on WMTE*, pp. 209-210, 2004.
- [6] L. Bollen, S. Eimler and H.U. Hoppe, The Use of Mobile Computing to Support SMS Dialogues and Classroom Discussions in a Literature Course. In *Proc. of the 4th IEEE ICALT*, pp. 550-554, 2004.
- [7] K. Gaßner, Diskussionen als Szenario zur Ko-Konstruktion von Wissen. Dissertation. Faculty of Engineering, University Duisburg-Essen, 2003.
- [8] N. Pinkwart, A Plug-In Architecture for Graph Based Collaborative Modelling Systems. In *Proceedings of the 11th International Conference on AIED*, pp. 535-536, 2003.
- [9] N. Pinkwart, Collaborative Modeling in Graph Based Environments. Dissertation. Faculty of Engineering Sciences, University Duisburg-Essen, 2005.

CIEL: Integrating Approaches for Inquiry Learning

Wouter van Joolingen, University of Twente, on behalf of the CIEL ERT.¹

Introduction

The world is changing and changing fast. Contemporary students live in a world full of impressions, fast changing viewpoints, ubiquitous information, zapping behaviour, play and joy etc. They use facilities such as MSN, on-line gaming, and SMS. They expect a seamless access to information, mostly in a social context. At the same time we see drastic changes in learning environments, moving them to rich, multi-media, collaborative, experiential, and individualised environments. Though starting from different angles, these two developments seem to come together. Modern learning environments such as WISE (Slotta, 2004) or BioLogica (Hickey, Kindfield, Horwitz, & Christie, 2003) combine all kinds of opportunities to learn and communicate in a facilitative setting.

In these learning environments, often called powerful learning environments (de Jong & Pieters, in press), specific design measures are taken to foster learning. In summary these design measures a) increase the engagement of learners, b) leverage the situatedness of learning, c) improve the quality of collaboration in learning, d) facilitate students in expressing their knowledge, e) scaffold students in employing key learning processes. Also, within the Kaleidoscope context, and more specifically the labs participating in this ERT proposal, a number of these encompassive learning environments that include one or more of the above mentioned design guidelines on different domains have been created. Examples are: CoolModes (Hoppe, 1999), SimQuest (van Joolingen & de Jong, 2003), Co-Lab (van Joolingen, de Jong, Lazonder, Savelsbergh, & Manlove, 2005), FLE (Leinonen, 2004; Mørch, Dolonen, & Omdahl, 2003), JEMUE (Baggetun & Dragsnes, 2003), ARI-LAB (Bottino & Chiappini, 2002) and Tangibles (Cerulli, Chiocciariello, Fernaeus, Lemut, & Tholander, 2005).

The CIEL project aims to achieve a level of integration between these diverse learning environments for inquiry and experiential learning. The two main reasons for this are:

- *Combining specializations.* Each tool has its merits of supporting specific parts of the collaborative inquiry learning process, including support for collecting data, modeling and specific means of collaboration. Instead of trying to create a single tool that can do it all CIEL strives to enable interoperability between tools.
- *Support of longer term learning scenarios.* Most learning environments support a specific type of activity, such as doing research on the greenhouse effect, or create a

¹ Persons who contributed to this demo are: Jakob Sikken, Andre Berloth (University of Twente), Lars Bollen, Björn Hassing, Ulrich Hoppe (University of Duisburg-Essen), Muriel Ney, Cedric d'Ham (MeTAH), Aleksander Krzywinski (University of Bergen), Augusto Chiocciariello (CNR) and Jeremy Toussaint (University of Oslo).

model of volcanic activity. This means that the typical duration of use will be limited. CIEL strives to design scenarios that extend over longer time periods, involving multiple activities and tools.

In a typical inquiry learning scenario that takes more than a few lesson periods, learners will perform diverse activities. Each of these activities will represent steps in the process of scientific knowledge building, and the whole scenario may therefore be supported by a variety of tools. CIEL aims to create an architecture in which many tools can interoperate to construct many different inquiry learning scenarios.

Figure 9 presents a possible example of such a scenario for inquiry learning, in which the learners collect data in a lab using a mobile device, and use the data to construct a model of the domain they are investigating using a modeling tool. In the mean time they can debate and construct an argument, using a dedicated argumentation builder such as Belvedere (Suthers, Weiner, Connelly, & Paolucci, 1995). The whole learning process is integrated around a common repository through which the different tools exchange information (e.g., data or models). On the one hand such a scenario should be *semantically integrated* (Koedinger, Suthers, & Forbus, 1999), meaning that the learning process as a whole, including the transitions from tool to tool take place in a smooth and meaningful way. On the other hand integration should also take place at a *technical level*, ensuring smooth data exchange between tools.

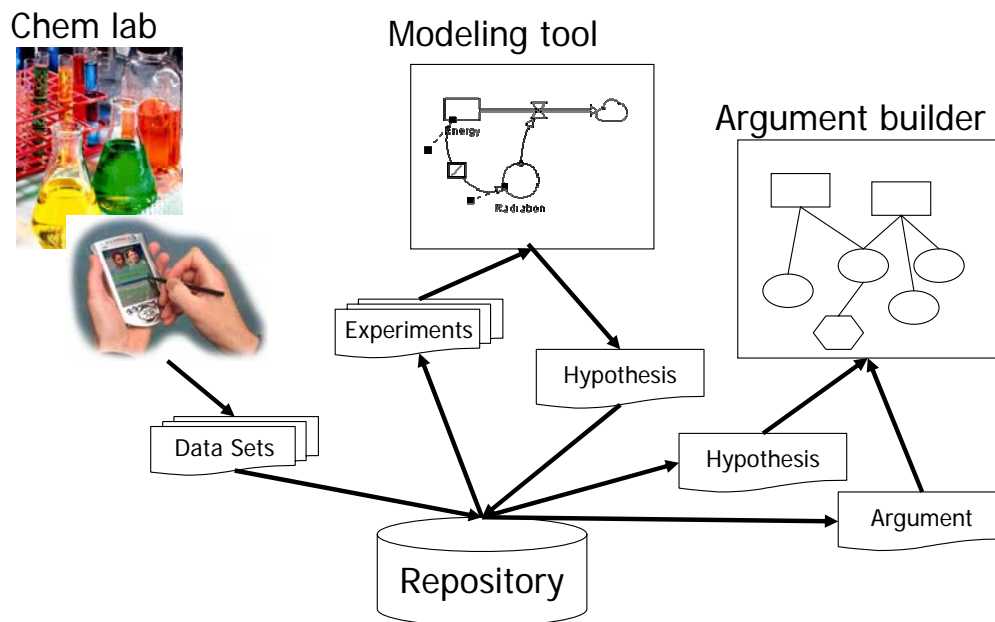

Figure 9 A multi-tool scenario to be supported by CIEL.

On the semantic level, it is important to support the flow of information and activity in the task context. This can be facilitated and implemented in different ways. One possibility is to map data onto specific objects that can be physically transferred (e.g., data can be captured on a PDA and thus be transferred). Another possibility is to transfer information between places and different environments by real time synchronization. In (Milrad, Hoppe, Gottdenker, & Jansen, 2004), several of such interoperability patterns are discussed from both an engineering and an educational design view.

Here the environments can possibly be heterogeneous. This second option requires a tight coupling in terms of processing and time constraints. A loose coupling which implies much less restrictions is often facilitated through a common repository, although a real time synchronization is not supported in a loose coupling model. It needs a common data format which can be 'understood' and generated by the different tools. In CIEL, we have first adopted the loosely coupled model for our technical approach.

CIEL aims to support both levels of integration by bringing together several systems that support collaborative inquiry learning and make them interoperate at the two indicated levels. At the semantic level CIEL works on integration of concepts such as learning processes, learning objects and learning tools. For each of these shared definitions are created that provide meaning to data that are stored. Examples of these definitions include “data set”, “experimental setup”, “phenomenon”, “experiment”, and “model”. Such definitions allow consistent support of learning processes across learning environment. If two systems treat the same object, for instance an “experiment” in a semantically consistent way, continuity of the learning scenario can be reached. The shared definitions in CIEL are created within a CIEL ontology.

The CIEL ontology also provides a context to the technical level of integration. In order to exchange data between tools, XML definitions are given of the terms in the ontology. This leads to a common data format shared by a set of tools that each can play a part in scenarios for collaborative inquiry and experiential learning. This approach is depicted in Figure 10.

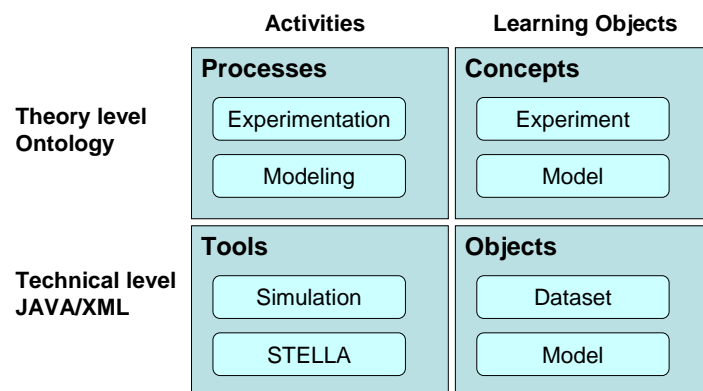

Figure 10 Structure of the CIEL work, depicted as two layers: theoretical and technical. The contents of the four cells are examples of a wider range of possible content.

The demonstrated system

The system demo consists of a first version of an integrated scenario along the lines described above. For the topic of “sampling” in the domain of statistics, a scenario has been designed and implemented that involves multiple activities and tools. The learner is placed in the role of an employee of a forest agency that is involved in the production of wood. For a certain forest area it must be determined whether the trees are tall and wide enough to harvest the wood. In doing so a sample of trees has to be taken. The task for the learner is to determine the best sampling strategy, so that a reliable decision can be made based upon the sample.

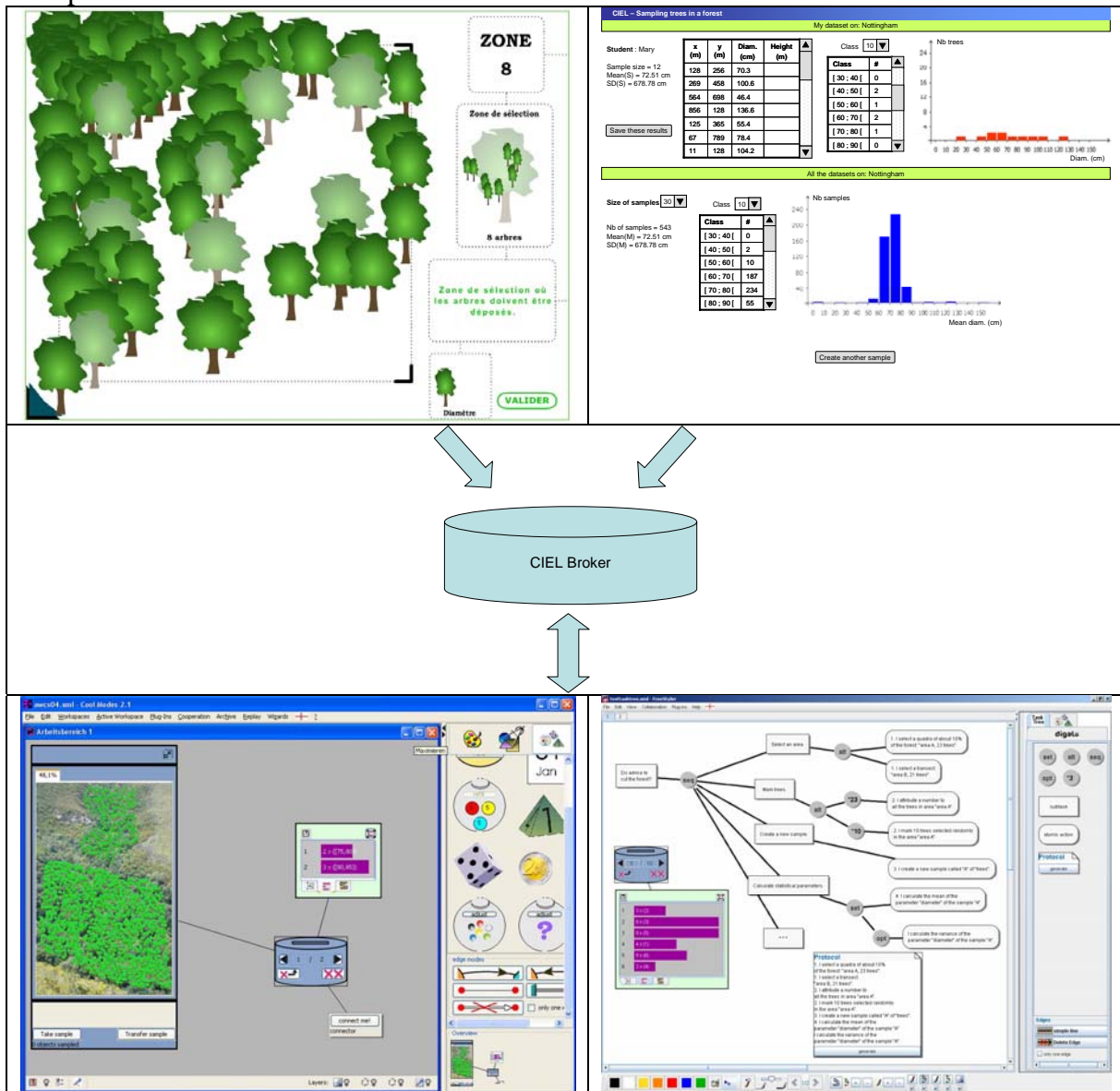

Figure 11 Overview of the demo. The two data generating tools at the top (Co-Lab and an independent flash application share their data with the broker. The data is used in FreeStyler modeling application depicted at the bottom.

The scenario is supported by two simulations, one in Flash and one made in Co-Lab. Both allow creating samples and computing parameters such as the average and standard deviations of each of the samples. The data from the samples are stored as learning objects in an XML format defined by the project and can be imported in Cool Modes and Freestyler, which are modeling tools that allow for modeling a variety of domains, including statistics. The sampling strategy can be modeled in FreeStyler.

Figure 11 provides an impression of the demo as well as the underlying architecture. Underlying the scenario are the definitions of datasets and models, as well as a working CIEL broker that allows for storage and retrieval of the objects produced by the learners. Tools can connect to the broker and store the objects, accompanied by automated generation of metadata, that helps with their retrieval.

The demonstrated scenario illustrates a step on the road that is pursued by CIEL towards a wider integration of tools, supporting different modes of collaboration and experimentation.

Demo requirements

The demo will be run from two brought-in laptops. Participants will be able to work with the applications. We will need a working internet connection from them (wired or wireless) as well as a beamer or large monitor to display the demo.

References

- Baggetun, R., & Dragsnes, S. (2003). Pedagogical agents for collaborative telelearning scenarios. In B. Wasson, S. Ludvigsen & U. Hoppe (Eds.), *Designing for Change in Networked Learning Environments*. (pp. 151-155). Dordrecht, The Netherlands: Kluwer Academic Publishers.
- Bottino, R. M., & Chiappini, G. (2002). Technological Advances and Learning Environments. In L. English (Ed.), *Handbook of International Research in mathematics Education* (pp. 757-786). Mahwah, New Jersey: Lawrence Erlbaum Associates.
- Cerulli, M., Chiocciariello, A., Fernaeus, Y., Lemut, E., & Tholander, J. (2005). *Exploring randomness via studying, building and sharing models*. Proceedings of the EARLI, Nicosia, Cyprus. (pp. 1-10).
- de Jong, T., & Pieters, J. M. (in press). The design of powerful learning environments. In P. A. Alexander & P. H. Winne (Eds.), *Handbook of Educational Psychology* (2nd ed.): Lawrence Erlbaum Associates.
- Hickey, D. T., Kindfield, A. C. H., Horwitz, P., & Christie, M. A. T. (2003). Integrating curriculum, instruction, assessment, and evaluation in a technology-supported genetics learning environment. *American Educational Research Journal*, 40, 495-538.
- Hoppe, H. U. (1999). Collaborative Learning in Open Distributed Environments - Pedagogical Principles and Computational Methods. *International Journal of Artificial Intelligence in Education*, 10, 1090-1099.
- Koedinger, K. R., Suthers, D., & Forbus, K. D. (1999). Component-based construction of a science learning space. *International Journal of AI and Education*, 10, 292-313.
- Leinonen, T. (2004). Fle3: Future Learning Environment. from <http://fle3.uiah.fi/>

- Milrad, M., Hoppe, U., Gottdenker, J., & Jansen, M. (2004). *Exploring the use of mobile devices to facilitate educational interoperability around around digitally enhanced experiments*. Proceedings of the 2nd IEEE International Workshop on Wireless and Mobile Technologies in Education (WMTE 2004). Los Alamitos, California (USA). (pp. 182-186) IEEE Press.
- Mørch, A., Dolonen, J., & Omdahl, K. (2003). Integrating agents with an open source learning environment. In Y. S. Chee, N. Law, K. T. Lee & D. Suthers (Eds.), *Proceedings of the International Conference on Computers in Education 2003 (ICCE 2003)* (pp. 393-401). Hong Kong: AACE Press.
- Slotta, J. D. (2004). The web-based inquiry science environment (WISE): Scaffolding knowledge integration in the science classroom. In M. Linn, E. A. Davis & P. Bell (Eds.), *Internet environments for science education* (pp. 203-233). Mahwah (NJ): Lawrence Erlbaum Associates.
- Suthers, D., Weiner, A., Connelly, J., & Paolucci, M. (1995). *Belvedere: Engaging students in critical discussion of science and public policy issues*. Proceedings of the II-Ed 95, the 7th World Conference on Artificial Intelligence in Education, Washington, DC. (pp. 1-31). Dordrecht: Kluwer Academic Publishers.
- van Joolingen, W. R., & de Jong, T. (2003). SimQuest: Authoring educational simulations. In T. Murray, S. Blessing & S. Ainsworth (Eds.), *Authoring tools for advanced technology educational software: Toward cost-effective production of adaptive, interactive, and intelligent educational software* (pp. 1-31). Dordrecht: Kluwer Academic Publishers.
- van Joolingen, W. R., de Jong, T., Lazonder, A. W., Savelsbergh, E., & Manlove, S. (2005). Co-Lab: Research and development of an on-line learning environment for collaborative scientific discovery learning. *Computers in Human Behavior*, 21, 671-688.

Collaborative Learning and Research Training: Towards a Doctoral Training Environment

J. Bourdeau*, F. Henri*, A. Dufresne**, J. Tchétagni*, R. Ben Ali*

**TELUQ-UQAM, 100 Sherbrooke W., Montreal, QC, H2X 3P2*

***Université de Montréal, CP 6128, Succ. Centre ville, Montreal, QC, H3C 3J7*

E-mail: bourdeau,henri,chetagni,benali@liceftelug.uqam.ca ;

aude.dufresne@liceftelug.uqam.ca

Abstract

Doctoral training has not been studied in depth as a learning situation, and no learning environment has been designed to specifically support actors involved in the training of future researchers. The research literature on doctoral education indicates that the knowledge about doctoral training needs to be made explicit and formalized. We claim that several problems brought up in the literature on PhD Training could be reduced or solved by a doctoral training environment designed on the basis of a cognitive analysis.

Doctoral training in the sciences consists essentially of research training through immersion in scientific communities and activities. Collaborative learning is built in authentic research situations, where doctoral students discover collaborative research. The model of a ‘Collaboratory’ provides the foundations for the practice of collaborative research. Future researchers are expected to be competent in practicing ‘E-science’ and knowledgeable about distributed research with remote access to shared instruments. The ability to practice ‘Co-experimentation’ is part of the research skills.

An authoring environment has been prototyped as well as an instantiation of a PhD program in the field of Cognitive Informatics. One Use Case consists of two or three research distributed teams sharing observations and discussions, a research training situation involving immersion and collaborative learning. A series of tests and co-experimentations involving Inquiry Learning Environments as a topic of study in the field of Technology-Enhanced Learning was conducted. An international collaboration happened through Kaleidoscope and the co-experimentations were made possible by an optical network infrastructure providing high quality interactions in terms of sharing and telepresence.

1. Introduction

What is doctoral training made of? This learning situation has not been studied thoroughly, nor have the problems of learning environments to support this situation in the field of Technology-Enhanced Learning (TEL).

We claim that immersion in scientific communities and participating in collaborative learning activities are two essentials of doctoral education. A research training environment should support these activities through interactions among several actors using top-level instrumentation. An analysis of actors, activities, resources, and competencies has been conducted in order to make explicit and to model the dynamics of research training through immersion in scientific communities and participating in collaborative learning activities. An authoring environment has been prototyped to support such activities inside specific PhD programs. One Use Case consists of two or three research distributed teams sharing observations and discussions, a research training situation involving immersion and collaborative learning. A series of tests and co-experimentations involving Inquiry Learning Environments as a topic of study in the field of Technology-Enhanced Learning was conducted. An international collaboration happened through Kaleidoscope and the co-experimentations were made possible by an optical network infrastructure providing high quality interactions in terms of sharing and telepresence.

This paper describes the problem tackled, the methodology that was selected, and the results obtained.

2. The problem

In their “Recommendations from National Studies on Doctoral Education”, Nyquist and Wulff [9] reviewed recent national studies on doctoral education in the US: “three themes that strongly emerge are:

Current graduate education does not adequately match the needs and demands of the changing academy and broader society; there is a lack of systematic, developmentally appropriate supervision for many who are seeking careers that require or benefit from the attainment of a Ph.D.; and there exists a growing concern about the high level of attrition among doctoral students". Problems brought up in the literature on doctoral training [1], [2], [3], [4], [5] include the lack of definition of expected competencies, the inadequation between program requirements and available research training activities.

We claim that the main reason for those problems is the lack of explicit knowledge about the nature and the characteristics of a doctoral training in general and of specific doctoral programs in particular. We believe that most programs share many common elements although they have different cultures, depending on the disciplines, countries and institutions.

The first issues triggered in this project deal with the process of making explicit and formalizing this knowledge which is required to design a DTE on a scientific basis.

Second, a doctoral training environment should be aware of current evolution in the scientific world, and be ready to support what is now called e-Science. The term was coined by John Taylor who stated: 'e-Science is about global collaboration in key areas of science and the next generation of infrastructure that will enable it' [6]. In the United Kingdom, e-Science projects span a range of disciplines from particle physics and astronomy to engineering and healthcare, and include international collaborative activities. Access to top-level instrumentation is a key to conducting e-Science, and optical networks are pivotal to this access.

In the spirit of a 'Collaboratory', the DTE needs to be equipped with a network infrastructure that can support immersion in a community and access to scientific instrumentation.

3. Methodology

First, a general characterization was carried out to draw the mandatory DTE orientations for the training of future generations of scientists, to prepare them for what is called 'E-science' [6]. An inspiring model, the Collaboratory [7], was selected and provided the foundations for practicing collaborative research. Two features were identified as essential for doctoral training: immersion in scientific activities (such as co-experimentation) and in communities, and access to

top-level instrumentation based on performance, safety, and privacy.

Then, a systematic analysis of processes, actors and resources was conducted, a fundamental step in designing a learning environment. Defining research competencies proved to be quite an ordeal. A substantial challenge concerns the support to developing research competencies, beginning with their explicitness.

Concerned with reusability, the team emphasized the fact that common grounds should be found for doctoral processes, and that generic learning objects or resources should be shareable as is recommended and now supported by recent technologies [8].

As a result, the team's objectives was to design an authoring system that allows DTE designers to instantiate their own DTE which reflects their own views, to pilot and instantiate a DTE in order to test and validate the ideas with authentic users placed in specific situations.

How can a doctoral training environment be sufficiently sophisticated to support the development of high-level skills through interaction among several actors using top-level instrumentation? An analysis of actors, activities, resources, and competencies has been conducted in order to make explicit and to model the dynamics of research training, and to obtain a design rationale.

4. Making Knowledge about PhD Training Explicit

Can the knowledge about PhD Training be made explicit? If so, why should this be? Traditionally, PhD supervisors resist the idea that it is possible and potentially beneficial to students for reasons such as: training methods are too peculiar, fuzzy, and interpersonal; it is better for students to discover by themselves, to make up their own mind and to pave their own way; it is the prerogative of each supervisor to say what they want to their students, etc.

Other reasons for this resistance could be the belief that doctoral training is so intertwined with research, and research is so competitive, that this knowledge ought to remain secret; or that doctoral education consists of initiating rather than training, and should therefore be transmitted 'by word of mouth'.

On the other hand, students often indicate they wish they had known in advance (and all along the process) what they should expect and what is expected from them [9], [10]. They also regret lacking a priori knowledge about the doctoral training process: "Had I

only known....” Such feelings might contribute to the high dropout rates.

Such a situation appears paradoxical for researchers in our field. Specializing in computer and cognitive sciences, and experienced in principled design of learning environments, a team such as ours, could not remain indifferent to this challenge.

Below is a short description of our analysis of the doctoral training process, and of research training competencies.

The next section introduces the building and testing of a lighthpath network, and the design of an e-controlled experimental laboratory. This is followed by a short description of co-experimentations, showing the inclusion of an international dimension in a private scientific network.

4.1. The Doctoral Training Process

From the very beginning, the team tackled the analysis of the main processes and sub-processes of doctoral training, as well as the actors and resources associated with them [11]. It soon became clear that it was impossible to strictly draw the line between processes common to most PhD programs and those which are specific to a discipline or an institution. A reasonable approximation was made: the doctoral training process can be split up into five main sub-processes. These sub-processes are: registration, academic program, student support, scientific immersion, student life, and career preparation (Fig.1). All of these sub-processes imply the participation of at least two of the following actors: student (enrolled in a program), professor, research staff, manager, and public (none of the above). These actors interact with each other and with the environment. A single user (human being) can play the roles of one or several actors.

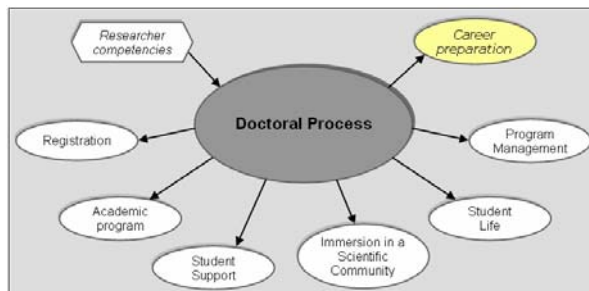

Fig. 1. The doctoral process

All actors cooperate in the pursuit of the goal of the doctoral training process: to support the development of research training competencies. Therefore, the whole process should be governed by these competencies and the need to support students developing their competencies. The PhD diploma is considered one expression of the recognition of the successful completion of the doctoral training process.

4.2. Research Training Competencies

Similarly to the analysis of the doctoral process, it was impossible to strictly distinguish between competencies common to most PhD programs from those which are specific to a discipline or an institution [12]. Another challenge consisted of reconciling competencies with skills and also sometimes with objectives, since these terms do not always share the same semantics, both in the literature [13], and in the actual everyday life of a PhD program [14]. The notion of competency itself is currently under scrutiny in order to orient the future design of an agent capable to diagnose these competencies. The list of skills proposed by the British Research Councils and the Arts and Humanities Research Board [15] was selected as a reasonable common basis for most PhD programs. These ‘Skills training requirements for research students’ are organized into five categories:

A) ‘Research skills and techniques - to be able to demonstrate skills such as: The ability to recognize and validate problems; Original, independent and critical thinking...

B) Research Environment - to be able to: show a broad understanding of the context, at the national and international level; understand the processes for funding and evaluation of research...

C) Research Management - to be able to: apply effective project management; design and execute systems for the acquisition and collation of information...

D) Personal Effectiveness - to be creative, innovative and original; demonstrate self-discipline...

E) Communication Skills – to write clearly and in a style appropriate to purpose, e.g. progress reports, published documents, thesis; to construct coherent arguments ...

F) Networking and Teamworking - to develop and maintain co-operative networks and working relationships ...

G) Career Management - to appreciate the need for and show commitment to continued professional development; to take ownership for and manage one's career progression...’

5. Results

This section introduces the results obtained so far: a prototype of a doctoral training environment with graph-based navigation and support to emergent activities within communities, the building and testing of a network infrastructure, the access to an e-controlled research laboratory, and the conduct of co-experimentations at the international level.

5. 1. Prototype of a Doctoral Training Environment

After extracting the design rationale, a prototype of a Doctoral Training Environment (DTE) was developed with its processes, actors, and resources. This section introduces the DTE Architecture and the implementation of the DTE authoring tool, called DTE-Author.

At the heart of the DTE is a set of links between conceptual entities: actors and their roles, activities and actions, competencies and resources. These links form the conceptual architecture [16], as illustrated in Fig. 2.

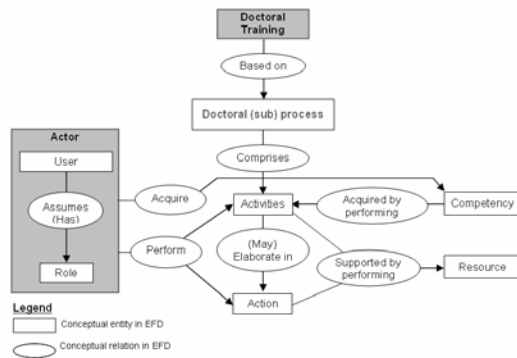

Fig. 2. The conceptual architecture of the DTE

This conceptual architecture provides the foundation for the functional architecture (Fig.3) and consequently the development of the DTE authoring tool.

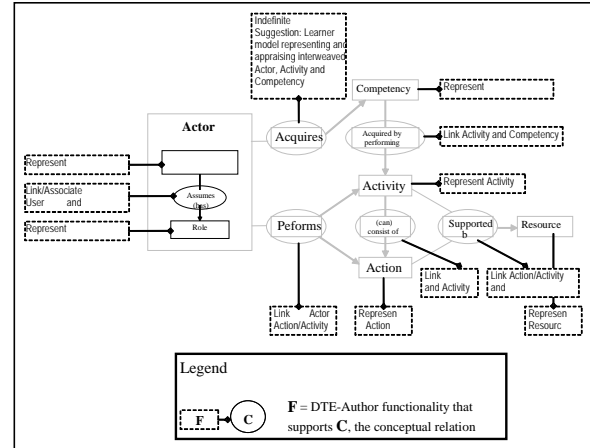

Fig. 3. The Functional Architecture of the DTE

This implementation is explained in video recordings for the users' benefit, to support them when designing an instantiation, i.e. a DTE-X.

The DTE Authoring Tool allows users to design and generate Doctoral Training Environments (DTE), hence its name: DTE-Author. It was built upon CONCEPT@, Télé-université's authoring environment, in connection with PALOMA, its learning objects repository. The rationale underlying the DTE-Author results from the cognitive analysis and includes three main features: 1) a doctoral process composed of six sub-processes: registration, program support, program activities, scientific immersion, student life and career preparation, 2) a competency model for future researchers, 3) interactions amongst various actors.

The goal of the DTE-Author is to allow users (authors) to create a process-based multi-actor environment specific to a given program (hereafter named DTE-X) that supports the development of competencies needed by future researchers. Thus, the authoring tool proposes the following method to design a DTE-X: 1) clarify each basic process in terms of doctoral activities, 2) specify each doctoral activity by linking it with the acquisition of a research competency, 3) assign specific resources and actors to each doctoral activity. The activity is considered as a set of actions, each action being carried out by an actor and supported by a resource.

The "author" is the only actor who uses the DTE-Author to design a DTE-X. The DTE design process is composed of four steps: identify the DTE-X, develop, configure, and generate the DTE-X. Each step is briefly described below:

1. Identify the DTE-X. This first step includes the following: name, select an abbreviation, and save. The

system launches the six doctoral sub-processes and its corresponding activities, illustrated by files in a tree diagram whose specific nodes represent learning activities.

2. Developing the DTE-X. The second step consists in defining its structure in detail: add/modify a sub-process, delete a doctoral sub-process, add/modify an activity within a process, delete an activity within a process.

3. Configuring the DTE-X. The third step consists in configuring the activities:

- Associate a research competency to an activity by selecting from a set of competencies or by adding another one

- Associate a resource to an activity. The DTE-Author includes four types of resources: application resources, NetNuke resources, generic resources and default resources. Application Resources consist of software which can be used for an activity. DNN Resources are resources used to design a DNN: newsgroups, e-filing, Weblist, etc. Generic Resources are documents: MS Office files, HTML, URL, pictures, videos, etc. For certain activities, the DTE-Author offers default resources that can belong to any of the three previous categories. Designers can view and select those considered most appropriate. Activity and resources deemed less relevant can be replaced by resources considered more appropriate. Designers can add their own applications.

- Associate an action to a specific activity if needed. The DTE-Author provides designers with two possibilities for each activity: select an action amongst a set of actions proposed for each activity; add a new action.

- Associate a resource with each action. To do so, authors consult or send a request to a Learning Objects Repository. Furthermore, they can select or add a new resource of their choice.

- Associate an actor with each resource involved in the activity. In the framework of this action, users' rights must be taken into consideration.

At this point, once all links have been created as illustrated in Fig 4, the instance, i.e. a DTE-X, can be generated.

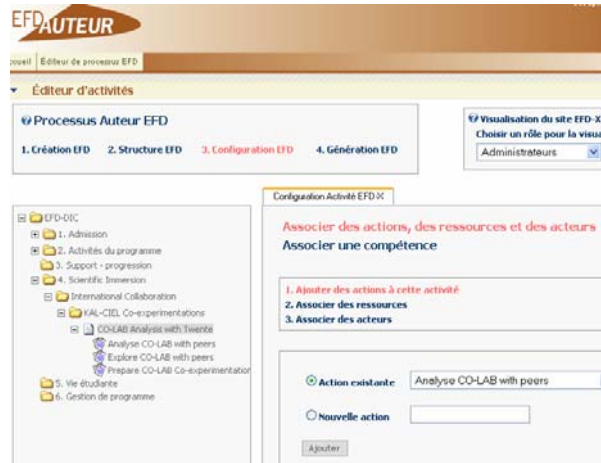

Fig. 4. Configuring the DTE-X

4. Generating the DTE-X. The fourth and last step consists of generating a Website or portal which supports this learning environment:

- Configure a generic/permanent Website menu that provides generic services (a CONCEPT@ functionality): select a template, test, and generate the DTE-X.

As a result, the user-author obtains a learning environment organized as a tree structure. However, she can also select an alternate mode to visualize this structure and navigate: the graph-based mode.

5.2. Graph-Based Navigation

The doctoral process can be viewed as an institutional accreditation process: institutional steps are well defined with rules for registration, academic program, thesis defense, etc. However, it is also a research and development process, where creativity, innovation and adaptation for individual research take an important part. For such areas, a more open and emergent coordination framework must be drawn. Although it is less organized and uniform, some kind of structure and support can be provided to coordinate activities amongst the academic participants, for example for a series of seminars, or to formalize emergent coordination between professors and their students, to ensure follow up, support and progress.

For those more open and emergent structures of activities, we decided to integrate Explor@Graph. This flexible navigation environment is based on conceptual maps, where different structures of activities, resources, concepts or others entities can be freely described and navigated according to users' rights. Explor@Graph first presents a metaphor

appropriate for the DTE: space exploration, brain neurons, connection amongst elements. Second, the system respects ergonomic principles for improved usability, offering high visibility, flexible navigation, progress feedback, collaborative features and adaptive interfaces to support progression. For example, it is possible to introduce dynamic help features, deadline reminders or simply remind users of the conference of the day.

Explor@Graph was developed from a standalone application in VB to a Web-based VB.Net version, called Explora@GraphNet. It was then linked to the DTE. Therefore, it offers graphic interfaces as an alternate browser within the DTE, exporting the process and sub-process structures, and allowing the creation of other more flexible structures with the Explor@Graph Editor. As a result, the system can display the same structures either as a tree diagram or a graph, and can launch the same resources in either mode. In order to integrate the processes defined in one mode or the other, we developed a framework of ontologically defined data exchange using a SESAME database. In this generic solution, (sub)process structures are defined as OWL structures, and an exportation module is specified from the DTE and from Explor@Graph to communicate process structures to the SESAME database. For flexible navigation within the DTE, Explora@GraphNet displays such structures (Fig.5).

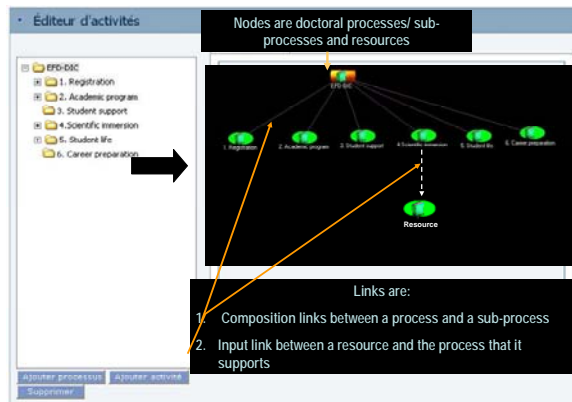

Fig. 5. Graph-based Navigation with Explora@GraphNet

This generic system could be used to communicate with other applications developed in the context of LORNET, such as resource or participant structures.

5.3. Emergent activities within communities

The need to ‘leave room for emergence’ was clearly expressed by the focus groups organized by the pilot team. The pilot study consists of instantiating a DTE-X for the PhD Program in Cognitive Informatics at TELUQ-UQAM, hereafter called DCI. As a result of two focus groups, one with professors and the other with students, the team decided to complement the DTE activity structure and to innovate by designing for emergent activities within communities – scientific community, program community, student community, etc. A conceptual and functional architecture is currently being designed to achieve this goal.

Our main challenge in designing DCI’s DTE is to materialize our conceptualisation of doctoral studies in terms of human communities. In our view, immersion into a scientific community is a key factor for a doctoral program because it permits doctoral students to get involved in authentic research situations allowing them to develop their research competencies and to get acquainted with the collaboration process within such communities. Collaboration among researchers at local, regional or international levels is fundamental to improve research productivity. Getting exposed to the activity of a research community is crucial for the training of doctoral students. Collaboration constitutes the locus for immersion into the scientific community. Since immersion is an emergent process that cannot be systematically planned, we had to find a way to induce and support it. Immersion in a scientific community banks on communication, sharing and networking and on people’s adhesion; it calls for influence, conviction and autonomy. Three main principles have been adopted to guide the design of the DCI’s DTE in terms of immersion in a scientific community. Firstly, doctoral processes and research competencies associated with them have to be made explicit to the students in order for them to be able to manage their own competency development. Secondly, the various resources that could support competency acquisition and immersion processes should be easy to access and to manage. Thirdly, communication and information flow should be highly transparent for students as well as for all members of the DCI program using the DCI’s DTE. These three principles are implemented in the DCI’s DTE mainly through the design of the interfaces, the creation of a personalized administration space, as well as by letting the members of the DCI’s community free to use their own tools (email, chat, blog, etc.), and by the use of RSS feed. Using an RSS aggregator allows

for the visualization and handling of consolidated information. It is an effective way to support information flow and the sharing of information. The home page is personalized and divided in three main sections. In the upper part, a TreeMap represents the doctoral processes, and indicates to students their own progress. In the lower part, the students access the various RSS feeds referenced and an interactive calendar that gives access to the feeds' history. There are two types of feeds: the ones created and selected by students and the mandatory ones given by the DCI's DTE manager (for example, News from the program, Changes in the program site, etc.). The heading, common to all pages of the environment, gives users access to their own administration space as well as to their favorite URLs and other RSS feeds. This home page has been designed to be easily integrated by the user in an external site. Giving the users the possibility to implement this page on their own site should stimulate their participation. Another section of the DCI's DTE gives access to a TreeMap representing the research competencies. It allows the students to manage their progress throughout the process of acquiring competencies.

The personal administration space allows users to manage their personal email addresses and syndication channels (RSS feeds), and to add their favorite RSS feeds and references. This space also identifies the resources and the information the user wants to access, and the resources and information she wants other members of the DCI's community to have access to.

As of instantiating the structured activities, such as the academic program, we started with the detailed specification of two use cases: registration and defense. These use cases involve all actors, require many interactions amongst them, and require services that can operate optimally over an optical network. The registration process involves the actor 'public' (potential student) who needs to share and present her intentions and portfolio to a potential supervisor; the supervisor introduces her research lab, team, and facilities, as well as expectations and requirements. The use case 'defense' involves the program 'manager' in the organization and ruling, and requires students to present and demonstrate their results (demos); members of the jury need a high performing network connection to share their views and discuss relevant issues. Obviously, many of these services are common with the services needed for immersion in scientific activities and communities.

5. 4. A Network Infrastructure

A lighthpath provides a scientific community with a network which is highly efficient, secure, and private. Such a network is currently being constructed between several universities in Canada and European partners in the field of Technology-Enhanced Learning. Called SCORE*, this program aims to support and test innovative ideas in the area of research training. The network architecture is illustrated in Fig 6. The SCORE lighthpath network is currently being implemented and tested in the BEST project to ensure it supports the DTE and the services it offers, such as videoconferencing, 3D models and simulations, and high resolution visualization. CANARIE provides the lighthpath connectivity within Canada over CA*net4 (Canadian backbone) and with the European partners, in conjunction with the SVL action of the Kaelidoscope network of excellence . The first measures proved to be close to theoretical values, including when testing with the University of Twente in the Netherlands.

A range of services is needed to support immersion and access to instrumentation. Integration of these services - videoconferencing for example- onto the network is a challenge in terms of quality of service (QoS) and of security.

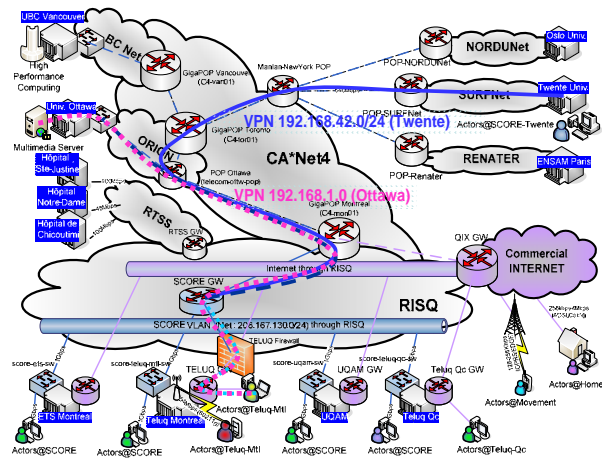

Fig. 6. The SCORE network architecture

An AccessGrid server has been configured to support multiple video-communications over this private optical network, since the network is not open to Internet and has no DNS infrastructure. It was tested with participants in Ottawa and Montreal visualizing and discussing a demo running jointly with video recordings. Participants expressed their satisfaction about the quality of the communication. Another test

will involve Vancouver and use the multipoint Access Grid mode. The multicast IP technology has been configured in order to improve the quality of service by reducing the latency in transmitting an audio and video flow duplicated to distributed participants. We expect this solution to provide an improved quality over the MCU Polycom since instead of sending a mosaic of low resolution images of participants, Access Grid will send these images with their original resolution.

Further development and testing include 3D applications, models and simulations, and high resolution visualisation.

5. 5. An E-controlled Experimental Lab

How can remote teams access experimental research laboratories? This is the challenge faced by the LORIT@D team in the BEST project. LORIT* is a Télé-université experimental research lab that allows the observation and capture of multimedia data from multiple pre-synchronized sources [17] In order for distributed teams to be able to conduct remote experiments, E-control is currently being implemented to allow observation, manipulation and data collection from remote or distributed locations, therefore called LORIT at a distance, or LORIT@D (Fig. 7).

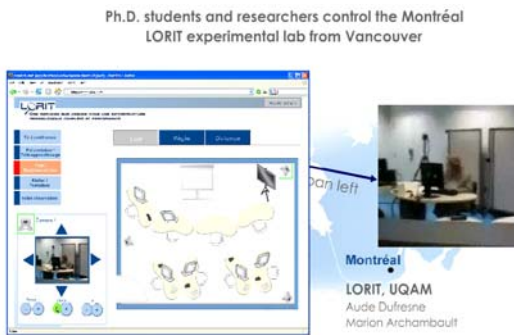

Fig. 7. The LORIT@D in action

User interface design raises specific challenges ranging from latency to cognitive load and perceptual accuracy. Such topics are currently being studied by two teams, in Montreal and in Vancouver.

The objectives of the BEST project for the LORIT@D are the following: 1) to install and program the control software for a new Web-based controller interface, 2) to study possible usage scenarios, 3) to program the controller interface for each of those scenarios, 4) to design a reservation and technical specification interface, to communicate with the

technical personnel and reserve the facility, 5) to run iterative tests and experiments with users in order to solve technical and usability problems.

A new e-Controller was installed and connected with two touch panels. They were programmed to display the control of the audiovisual and telecom equipment of the LORIT: cameras, whiteboard, projector, audio and video matrices, Polycom bridges. The Web interface allows participants to control it remotely through the XPanel. Several scenarios were developed in collaboration with UBC and Simon Fraser University. A series of tests were conducted to test the technology, and to fine tune the scenarios. Further tests with users will assess the LORIT@D technical performance and usability both with and without the lighthpath connection. The lighthpath connection reduces latency to its absolute minimum. Propagation delay of the optical signal ($2 \times 45 = 90$ msec for an approximate lighthpath length of 4800km between Montréal and Vancouver) and a minimum transmission delay ($2 \times 8\text{kb}/1\text{Gbps} = 16 \mu\text{sec}$ for a 1Gbps optical route) provides this minimal latency. Note that this minimal latency is uncompressible and corresponds to the speed of light. Most E-control applications and remote manipulation of instruments require this reduced latency, as LORIT@D does. Another advantage of using the 1Gbps bandwidth over a private lighthpath is to transmit high resolution videoconferencing without reducing the quality of service. Observations can be improved by an order of magnitude, and scientific discussions can be more efficient, as is needed in co-experimentation settings.

5. 6. Co-experimentations

Co-experimentations are typical activities in a 'Collaboratory', and they require a thorough preparation in terms of research protocol as well as of technical support. Aside the LORIT@D work reported in the previous section, other innovative ways of co-experimenting have been organized and investigated, at the national and international levels.

In conjunction with our partners from the KALEIDOSCOPE European research network in the field of Technology-Enhanced Learning, we prepared a co-experimentation where two research teams composed of PhD students and researchers discussed by holding a videoconference and running application sharing software [18]. Both teams used called 'Co-Lab' applications [19] to share the manipulation, observation and argumentation protocol (Fig. 9). This activity is also part of the CIEL project in Kaleidoscope. For doctoral students, this activity can

be specified as a collaborative learning activity in the sense of CSCL scripting [20]. The first action consists of using Co-Lab: observe a phenomenon by running real time simulations; elaborate a theory by manipulating data and objects collaboratively using a co-modeling tool; evaluate a theory by viewing and manipulating simulations; eventually return to observation activities. The second action is dedicated to analyzing the inquiry process, and discussing the research methods used.



Fig. 9. Co-experimenting with Co-Lab between Montreal and Twente

One conclusion from this co-experimentation is that a high quality of audio and video is essential for participants to feel totally immersed or even to ideally forget the distance and the technology. In this case, the Polycom videoconferencing system provided a good quality of videocommunication thanks to the 1Gbps link between the LICEF research center in Montreal and the Université de Twente in the Netherlands. Using text-based communication – the only way to support collaboration in Colab, proved to be very limiting and was used mainly to establish the video connection and solve technical problems related to it.

6. Conclusion and Future Work

Realizations of the BEST project presented in this paper illustrate our search for innovative ideas to support the training of doctoral students through a learning environment aware of the actors, processes and resources involved. Collaborative learning and immersion in scientific communities and activities are two essential features of doctoral training; access to instrumentation for distributed research is a requirement in many situations. An analysis provided the rationale for designing and weaving the learning environment. A prototype was developed and tested –

the DTE authoring tool. It allows designers to create instantiations that correspond to their needs, while incorporating basic knowledge about doctoral training that is ‘built-in’ the authoring tool. Co-experimentations between two teams at the international level were conducted over an optical network which provides quality interactions and security.

The next step in this project is to continue our series of co-experimentations, with a research protocol that integrates a third team, at the University of Oslo, and subsequently at the University of Bergen. Another research avenue consists of designing agents that can support actors with difficult tasks, such as diagnosing competencies.

References

- [1] L. McAlpine and J. Norton, "Reframing our approach to doctoral programs: an integrative framework for action and research", *Higher Education Research and Development*, (25) 1, 2006, pp. 3 – 17.
- [2] Lindner, J. R., Dooley, K.E. and Murphy, T.H. "Differences in Competencies between Doctoral Students On-Campus and at a Distance". *The American Journal of Distance Education*, vol. 15, no. 2, 2001, pp. 25-40.
- [3] G. Kearsley, *Doing Doctoral Work at a Distance*. <http://home.sprynet.com/~gkearsley/doctoral.htm>
- [4] J. Bourdeau, F. Henri and N. Ozkan, "Doctorate at a Distance (D@D): In Search of Serendipity", in G. Richards (Ed.), *Proceedings of World Conference on E-Learning in Corporate, Government, Healthcare, and Higher Education*, AACE, Chesapeake, VA, 2002, pp. 2009-2012.
- [5] NSERC, *Report of the Task Force on Virtual Universities and Online Learning*, 2003, http://www.nserc.gc.ca/about/researchbase_e.htm
- [6] T. Hey and A. Trefethen, "The UK e-Science Core Programme and the Grid", *Future Generation Computer Systems*, (18) 8, 2002, pp. 1017-1031.
- [7] G. Olson, T. Malone and J. B. Smith, *Coordination Theory and Collaboration Technology*, Lawrence Erlbaum Associates, Mahwah, NJ, 2001.
- [8] G. Paquette, "Apprentissage sur l'Internet : des plateformes aux portails à base d'objets de connaissance", in S. Pierre (Éd.), *Innovations et tendances en technologies de formation et d'apprentissage*, Les Presses internationales de Polytechnique, Montréal, 2005, pp. 1-29.

[9] FES, *L'encadrement des étudiants aux études supérieures*, Faculté des études supérieures, Université de Montréal, 2000, <http://www.fes.umontreal.ca/Fichiers/encadrement-professeur.pdf>

[10] CAGS, Canadian Association for Graduate Studies, *Your future: a guide for potential graduate students*, 2005, <http://www.cags.ca/publications/publications.html>

[11] C. Paquin, J. Cano, J. Bourdeau, F. Henri, J. Tchétagani, *Analyse préliminaire et architecture conceptuelle*, BEST Technical Report, Montréal, 2005.

[12] R. Gilbert, J. Balatti, P. Turner and H. Whitehouse, "The generic skills debate in research higher degrees", *Higher Education Research & Development*, 23 (3), 2004, pp. 375-88.

[13] G. Paquette, *Modélisation des connaissances et des compétences*, Presses de l'Université du Québec, Sainte-Foy, 2002.

[14] USF College of Public Health, *PhD Program Competencies*, <http://publichealth.usf.edu/>

[15] The Research Councils and the Arts and Humanities Research Board, *Skills training requirements for research students*, UK, 2001, http://www.grad.ac.uk/cms/ShowPage/Home_page/Policy/National_policy/Research_Councils_training_requirements/plaLXeFl

[16] J. Tchetagni, *Modèle conceptuel de l'EFD*, BEST Technical Report, Montréal, 2006.

[17] J. Bourdeau, A. Dufresne, S. Prom Tep, and S. Turcotte. "Test et validation des environnements de Téléapprentissage", in S. Pierre (Éd.), *Innovations et tendances en technologies de formation et d'apprentissage*, Les Presses internationales de Polytechnique. Montréal, 2005, pp. 479-497.

[18] J. Tchetagni and R. BenAli, *Co-experimentation report*, BEST Technical Report, Montréal, 2006.

[19] van Joolingen, W. R., de Jong, T., Lazonder, A. W., Savelsbergh, E., & Manlove, S. (2005). Co-lab: Research and development of an on-line learning environment for collaborative scientific discovery learning. *Computers in Human Behavior*, 21, 671-688.

[20] P. Dillenbourg and P. Jermann, SWISH: A model for designing CSCL scripts, in F. Fisher, H. Mandl, J. Haake and I. Kollar (Eds), *Scripting Computer Supported Collaborative Learning – Cognitive, Computational and Educational Perspective*, CSCL Series, NY: Springer Verlag, 2006.

Acronyms and credits

- The BEST (Banc d'Essai de Services de liaisons optiques pour un environnement de Téléformation doctorale) project is an R&D project under the CA*net 4 Advanced Applications Program (AAP), 2005-2006, <http://www.canarie.ca/funding/applications/projects.html>

- The BEST team is composed of Chantal Paquin, Jacqueline Bourdeau, France Henri, Abed ElSaddik, Abdur Rahman, M. Kafi, Aude Dufresne, Brian Fisher, Barry Po, Lee Iverson, Roland Yatchou, Racha Ben Ali, Juliana Cano, Lysanne Lessard, Jean-Christophe Denaes, Mohamed Rouatbi, Alexandre Sauriol, Patrick-Fulgence Goudjo-Ako, Joséphine Tchétagani, Michel Roy, Mihai Tabaras, Serge Castonguay. Collaborators : Wouter van Joolingen, Barbara Wasson, Sten Ludvigsen, Samuel Pierre, Roger Nkambou, Nicola Hagemester, Pierre Gagné, Kelly Booth (NECTAR NoE). RISQ (Quebec operator for universities) operates the network and runs technical tests.

- SCORE (Environnement distribué de Soutien au Communautés de Recherche scientifique, virtuelles et internationales et à leur RELève) is a research program, with an infrastructure funded by the CFI and the Gov. of Quebec, 2005-2008. BEST is part of the SCORE research program.

- KALEIDOSCOPE is a European Network of Excellence in Technology-Enhanced Learning, <http://www.noekaleidoscope.org>. The participation of Télé-université as a contractor is supported financially by the Gov. of Quebec under the PSIRI program.

- SVL (Shared Virtual Lab) is an action of the KALEIDOSCOPE European Network of Excellence

- CIEL (Collaborative Inquiry and Experiential Learning) is a Kaleidoscope European Research Team under the direction of Prof. Wouter van Joolingen, U. of Twente, <http://kaleidoscope.gw.utwente.nl/CIEL/>

Le laboratoire Leibniz est fortement pluridisciplinaire. Son activité scientifique couvre un large domaine qui comprend aussi bien des thèmes fondamentaux que des thèmes très liés aux applications, aussi bien en mathématiques qu'en informatique.

Les recherches sur les Environnements Informatiques d'Apprentissage Humain et la didactique des mathématiques ouvrent cette pluridisciplinarité sur les sciences humaines, elles jouent un rôle particulier en favorisant les coopérations entre différentes composantes du laboratoire.

- * mathématiques discrètes et recherche opérationnelle
- * logique et mathématique pour l'informatique
- * informatique de la connaissance
- * EIAH et didactique des mathématiques

Les cahiers du laboratoire Leibniz ont pour vocation la diffusion des rapports de recherche, des séminaires ou des projets de publication réalisés par des membres du laboratoire. Au-delà, Les cahiers peuvent accueillir des textes de chercheurs qui ne sont pas membres du laboratoire Leibniz mais qui travaillent sur des thèmes proches et ne disposent pas de tels supports de publication. Dans ce dernier cas, les textes proposés sont l'objet d'une évaluation par deux membres du Comité de Rédaction.

Comité de rédaction : Nicolas Balacheff, Mirta Gordon, Denise Grenier, Yves Demazeau, Andras Sebo

Contact Gestion & Réalisation : Jacky Coutin
Directeur de la publication : Nicolas Balacheff
ISSN : 1298-020X - © laboratoire Leibniz