



Aggregation on bipolar scales

Michel GRABISCH

Université Paris I - Panthéon-Sorbonne
CERMSEM, 110-116 Bd de l'Hôpital, 75013 Paris, France
Michel.Grabisch@lip6.fr

Abstract. The paper addresses the problem of extending aggregation operators typically defined on $[0, 1]$ to the symmetric interval $[-1, 1]$, where the "0" value plays a particular role (neutral value). We distinguish the cases where aggregation operators are associative or not. In the former case, the "0" value may play the role of neutral or absorbant element, leading to pseudo-addition and pseudo-multiplication. We address also in this category the special case of minimum and maximum defined on some finite ordinal scale. In the latter case, we find that a general class of extended operators can be defined using an interpolation approach, supposing the value of the aggregation to be known for ternary vectors.

1 Introduction

Most of the works done on aggregation operators take the $[0, 1]$ interval as range for quantities to be aggregated, or some similar structure, i.e. a closed interval of some linearly ordered set (see, e.g., [3, 17, 21]). The lower and upper bounds of this interval represent the worst and best scores that can be achieved on each dimension.

We may desire to introduce a third remarkable point of the interval, say e , which will play a particular role, for example a neutral value (in some sense) or an absorbant value. This situation is already considered for uninorms [28]: e is a neutral element in the sense that, U denoting a uninorm, $U(e, x) = x$ for any $x \in [0, 1]$.

For convenience, up to a rescaling, we may always consider that we work on $[-1, 1]$, and 0 corresponds to our particular point, denoted e before. In the more general case of bounded linearly ordered sets, we will apply a symmetrization procedure.

The motivation for such a work may be only mathematical. However, there are psychological evidence that in many cases, scores or utilities manipulated by humans lie on a *bipolar scale*, that is to say, a scale with a neutral value making the frontier between good or satisfactory scores, and bad or unsatisfactory scores. With our convention, good scores are positive ones, while negative scores reflect bad scores. Most of the time, our behaviour with positive scores is not the same than with negative ones: for example, a conjunctive attitude may be turned into a disjunctive attitude when changing the sign of the scores. So, it becomes

important to define aggregation operators being able to reflect the variety of aggregation behaviours on bipolar scales.

Let M be an aggregation operator defined on $[-1, 1]$. Clearly, the restriction of M to non negative numbers corresponds to some (usual) aggregation operator M^+ on $[0, 1]$. Similarly, its restriction to $[-1, 0]$ corresponds to a (possibly different) operator M^- , after some suitable symmetrization. However, this does not suffice to define the value of M for the mixed case, when positive and negative scores coexist. The exact way to do this is dependent on the nature of M and the meaning of 0. We shall distinguish several cases.

Let us consider first that M is associative, so that we need to consider only two arguments. For the meaning of the 0 point, we can think of two cases of interest: either 0 is a neutral value in the sense that $M(0, x) = M(x, 0) = x$ for any $x \in [-1, 1]$, or 0 is an absorbing value, i.e. $M(0, x) = M(x, 0) = 0$, for any $x \in [-1, 1]$. The first case leads naturally to pseudo-additions, while the second one leads to pseudo-multiplications. This is the topic of Section 3. The particular case of the definition of min and max on $[-1, 1]$ will be addressed in Section 4, where we deal with symmetrized linearly ordered sets.

Let us consider now (possibly) non associative aggregation operators. A first important class of operators are those under the form:

$$M(x) := \phi(M^+(x^+), M^-(x^-)) \tag{1}$$

where $x \in [-1, 1]^n$ for some n , and $x^+ := x \vee 0$, $x^- := (-x)^+$, M^+, M^- are given aggregation operators on $[0, 1]$, and ϕ is a pseudo-difference. We call such aggregation operators *separable*. A more general case is defined as follows. We say that x is a *ternary vector* if $x \in \{-1, 0, 1\}^n$ for some n . Let us suppose that the value of M for each ternary vector is given. Then we define M for every $x \in [-1, 1]^n$ by some interpolation rule between the known values. The separable case is recovered if M^+ and M^- are also obtained by some interpolation rule. As in the usual unipolar case, we will show that this type of aggregation operator is based on an integral (Section 6). We begin by a preliminary section introducing necessary definitions.

2 Basic material

We begin by recalling definitions of t-norms, t-conorms, uninorms and nullnorms (see, e.g., [19, 21] for details).

Definition 1. A triangular norm (*t-norm for short*) T is a binary operation on $[0, 1]$ such that for any $x, y, z \in [0, 1]$ the following four axioms are satisfied:

- (P1) *commutativity*: $T(x, y) = T(y, x)$;
- (P2) *associativity*: $T(x, T(y, z)) = T(T(x, y), z)$;
- (P3) *monotonicity*: $T(x, y) \leq T(x, z)$ whenever $y \leq z$;
- (P4) *neutral element*: $T(1, x) = x$.

Any t-norm satisfies $T(0, x) = 0$. Typical t-norms are the minimum (\wedge), the algebraic product (\cdot), and the Łukasiewicz t-norm defined by $T_{\mathbf{L}}(x, y) := (x + y - 1) \vee 0$.

Definition 2. A triangular conorm (*t-conorm for short*) S is a binary operation on $[0, 1]$ such that, for any $x, y, z \in [0, 1]$, it satisfies **P1**, **P2**, **P3** and

(P5) neutral element: $S(0, x) = x$.

Any t-conorm satisfies $S(1, x) = 1$. Typical t-conorms are the maximum \vee , the probabilistic sum $S_{\mathbf{P}}(x, y) := x + y - xy$, and the Łukasiewicz t-conorm defined by $S_{\mathbf{L}}(x, y) := (x + y) \wedge 1$. T-norms and t-conorms are dual operations in the sense that for any given t-norm T , the binary operation S_T defined by

$$S_T(x, y) = 1 - T(1 - x, 1 - y)$$

is a t-conorm (and similarly when starting from S). Hence, their properties are also dual. The above examples are all dual pairs of t-norms and t-conorms.

A t-norm (or a t-conorm) is said to be *strictly monotone* if $T(x, y) < T(x, z)$ whenever $x > 0$ and $y < z$. A continuous t-norm (resp. t-conorm) is *Archimedean* if $T(x, x) < x$ (resp. $S(x, x) > x$) for all $x \in]0, 1[$. A strictly monotone and continuous t-norm (resp. t-conorm) is called *strict*. Strict t-norms (resp. t-conorms) are Archimedean. Non-strict continuous Archimedean t-norms (resp. t-conorms) are called *nilpotent*.

Any continuous Archimedean t-conorm S has an additive generator s , i.e. a strictly increasing function $s : [0, 1] \rightarrow [0, +\infty]$, with $s(0) = 0$, such that, for any $x, y \in [0, 1]$:

$$S(x, y) = s^{-1}[s(1) \wedge (s(x) + s(y))]. \quad (2)$$

Similarly, any continuous Archimedean t-norm has an additive generator t that is strictly decreasing and satisfies $t(1) = 0$. Strict t-conorms are characterized by $s(1) = +\infty$, nilpotent t-conorms by a finite value of $s(1)$. Additive generators are determined up to a positive multiplicative constant. If t is an additive generator of a t-norm T , then $s(x) = t(1 - x)$ is an additive generator of its dual t-conorm S_T .

Definition 3. [28] A uninorm U is a binary operation on $[0, 1]$ such that, for any $x, y, z \in [0, 1]$, it satisfies **P1**, **P2**, **P3** and

(P6) neutral element: there exists $e \in]0, 1[$ such that $U(e, x) = x$.

It follows that on $[0, e]^2$ a uninorm behaves like a t-norm, while on $[e, 1]^2$ it behaves like a t-conorm. In the remaining parts, monotonicity implies that U is comprised between min and max. Associativity implies that $U(0, 1) \in \{0, 1\}$. Uninorms such that $U(0, 1) = 1$ are called disjunctive, while the others are called conjunctive.

If U is a uninorm with neutral element e , strictly monotone on $]0, 1[^2$, and continuous on $[0, 1]^2 \setminus \{(0, 1), (1, 0)\}$, there exists an additive generator u , i.e. a

strictly increasing $[0, 1] \rightarrow [-\infty, \infty]$ mapping u such that $u(e) = 0$ and for any $x, y \in [0, 1]$:

$$U(x, y) = u^{-1}(u(x) + u(y)), \quad (3)$$

where by convention $\infty - \infty = -\infty$ if U is conjunctive, and $+\infty$ if U is disjunctive.

Definition 4. [2] A nullnorm V is a binary operation on $[0, 1]$ such that for any $x, y, z \in [0, 1]$, it satisfies **P1**, **P2**, **P3**, and there is an element $a \in [0, 1]$ such that

$$V(x, 0) = x, \quad \forall x \leq a, \quad V(x, 1) = x, \quad \forall x \geq a.$$

By monotonicity, $V(x, a) = a$ for all $x \in [0, 1]$, hence a is an absorbant value, and V restricted to $[0, a]^2$ is a t-conorm, while its restriction to $[a, 1]^2$ is a t-norm. Remark that this is the opposite situation of uninorms. On the remaining part of $[0, 1]^2$, monotonicity imposes that $V(x, y) = a$. Hence to each pair of t-norm and t-conorm corresponds a unique nullnorm, provided a is fixed.

We turn to the definition of Choquet and Sugeno integrals. We denote by $[n]$ the set $\{1, \dots, n\}$ of the n first integers, which will be the number of arguments of our aggregation operators. Details on what follows can be found in, e.g., [16].

Definition 5. A (normalized) capacity is a function $\mu : 2^{[n]} \rightarrow [0, 1]$ satisfying $\mu(\emptyset) = 0$, $\mu([n]) = 1$, and $\mu(A) \leq \mu(B)$ for every $A, B \in 2^{[n]}$ such that $A \subseteq B$.

To any capacity μ we associate its conjugate $\bar{\mu}$, which is a capacity defined by:

$$\bar{\mu}(A) := 1 - \mu([n] \setminus A), \quad A \subseteq [n].$$

Definition 6. Let $x \in [0, 1]^n$ and μ be a capacity on $[n]$.

(i) The (discrete) Choquet integral of x w.r.t. μ is defined by:

$$\mathcal{C}_\mu(x) := \sum_{i=1}^n [x_{\sigma(i)} - x_{\sigma(i-1)}] \mu(\{x_{\sigma(i)}, \dots, x_{\sigma(n)}\}),$$

with σ indicating a permutation on $[n]$ such that $x_{\sigma(1)} \leq \dots \leq x_{\sigma(n)}$, and $x_{\sigma(0)} := 0$.

(ii) The (discrete) Sugeno integral of x w.r.t. μ is defined by:

$$\mathcal{S}_\mu(x) := \bigvee_{i=1}^n [x_{\sigma(i)} \wedge \mu(\{x_{\sigma(i)}, \dots, x_{\sigma(n)}\})],$$

with same notations.

These two aggregation operators being integrals, they are called *integral-based* operators. Others can be defined, considering other integrals defined w.r.t capacities and based on pseudo-additions and pseudo-multiplications (see, e.g., Murofushi and Sugeno [23], Benvenuti et al. [1], and Sander and Siedekum [24–26]).

For any $A \subseteq [n]$, let us denote by $(1_A, 0_{A^c})$ the vector x of $[0, 1]^n$ such that $x_i = 1$ if $i \in A$ and 0 else. These are the set of vertices of $[0, 1]^n$. An important property is that for any capacity μ , $\mathcal{C}_\mu(1_A, 0_{A^c}) = \mathcal{S}_\mu(1_A, 0_{A^c}) = \mu(A)$ for all $A \subseteq [n]$. Moreover, as explained hereafter, the Choquet integral is the only linear interpolator using the fewest number of vertices of $[0, 1]^n$ (see [9, 15]).

Let us denote by F an aggregation operator on $[0, 1]^n$ such that for any $A \subseteq [n]$, $F(1_A, 0_{A^c}) = \mu(A)$ for a given capacity μ . Let us find a linear interpolation using the fewest possible vertices of $[0, 1]^n$. For a given $x \in [0, 1]^n$, let us denote by $\mathcal{V}(x)$ the set of vertices used for the linear interpolation, which writes

$$F(x) = \sum_{A \subseteq [n] | (1_A, 0_{A^c}) \in \mathcal{V}(x)} \left[\alpha_0(A) + \sum_{i=1}^n \alpha_i(A)x_i \right] F(1_A, 0_{A^c}), \quad (4)$$

where $\alpha_i(A) \in \mathbb{R}$, $i = 0, \dots, n$, $\forall A \in \mathcal{V}(x)$. To keep the meaning of interpolation, we impose that the convex hull $\text{conv}(\mathcal{V}(x))$ contains x , and any $x \in [0, 1]^n$ should belong to a unique polyhedron $\text{conv}(\mathcal{V}(x))$ (except for common facets), and continuity should be ensured. Hence, the hypercube is partitioned into q polyhedra defined by their sets of vertices $\mathcal{V}_1, \dots, \mathcal{V}_q$, all vertices being vertices of $[0, 1]^n$. Such an operation is called a *triangulation*. Note that the least possible number of vertices is $n + 1$, otherwise the polyhedra would not be n -dimensional, and hence a finite number would not cover the whole hypercube.

Many different triangulations are possible, but there is one which is of particular interest, since it leads to an interpolation where all constant terms $\alpha_0(A)$ are null. This triangulation uses the $n!$ *canonical polyhedra* of $[0, 1]^n$:

$$\text{conv}(\mathcal{V}_\sigma) = \{x \in [0, 1]^n \mid x_{\sigma(1)} \leq \dots \leq x_{\sigma(n)}\}, \text{ for some permutation } \sigma \text{ on } [n].$$

Note that all these polyhedra have $n + 1$ vertices.

Proposition 1. *The linear interpolation (4) using the canonical polyhedra is the Choquet integral w.r.t. μ . Moreover, no other triangulation using polyhedra of $n + 1$ vertices can lead to an interpolation.*

As shown in [9], the Sugeno integral is the lowest possible max-min interpolation between vertices in the canonical triangulation.

3 Pseudo-additions and multiplications

In this section, we work on interval $[-1, 1]$. Our aim is to define associative operators where 0 is either a neutral or an absorbing element, which we will suppose commutative in addition. Let us denote respectively $\oplus, \otimes : [-1, 1]^2 \rightarrow [-1, 1]$ these operators, and let us adopt an infix notation. In summary, they should fulfil the following requirements for any $x, y, z \in [-1, 1]$:

- R1** Commutativity: $x \oplus y = y \oplus x$, $x \otimes y = y \otimes x$.
- R2** Associativity: $x \oplus (y \oplus z) = (x \oplus y) \oplus z$, $x \otimes (y \otimes z) = (x \otimes y) \otimes z$.
- R3** $x \oplus 0 = x$, $x \otimes 0 = 0$.

Endowing $[-1, 1]$ with the usual ordering, we may require in addition that \oplus is monotone in each argument. As observed by Fuchs [6], under the assumption of monotonicity, associativity implies that \oplus cannot be decreasing. Indeed, suppose e.g. \oplus is decreasing in first place and take $x' \leq x$. Then $x' \oplus (y \oplus z) \geq x \oplus (y \oplus z) = (x \oplus y) \oplus z \geq (x' \oplus y) \oplus z = x' \oplus (y \oplus z)$, a contradiction unless \oplus is degenerate. Hence we are lead to assume **R4**. For \otimes , let us require for the moment that it is monotone only on $[0, 1]$, which leads to **R5**.

R4 Isotonicity for \oplus : $x \oplus y \leq x' \oplus y$, for any $x' \leq x$.

R5 Isotonicity on $[0, 1]^2$ for \otimes .

The above requirements make that we recognize \oplus as a t-conorm when restricted to $[0, 1]^2$. To make \otimes on $[0, 1]^2$ a t-norm, we need in addition the following:

R6 Neutral element for \otimes : $x \otimes 1 = x$, for all $x \in [0, 1]$.

Let us call \oplus, \otimes satisfying **R1** to **R6** *pseudo-addition* and *pseudo-multiplication*.

We address first the construction of \oplus . Since $[-1, 1]$ is a symmetric interval, and if 0 plays the role of a neutral element, then we should have

R7 Symmetry: $x \oplus (-x) = 0$, for all $x \in [-1, 1]$.

Under **R1**, **R2**, **R3**, **R4**, and **R7**, the problem of defining \oplus amounts to defining an ordered group on $[-1, 1]$ (see Fuchs [6] and [20, 19]). We recall here necessary notions and facts.

Definition 7. Let (W, \leq) be a linearly ordered set, having top and bottom denoted \top, \perp , a particular nonextremal element e , and let us consider \oplus an internal binary operation on W , and \ominus a unary operation such that $x \leq y$ iff $\ominus(x) \geq \ominus(y)$.

- $(W, \leq, \oplus, \ominus, e)$ is an ordered Abelian group (OAG) if it satisfies for all nonextremal elements x, y, z :
 - (i) $x \oplus y = y \oplus x$
 - (ii) $x \oplus (y \oplus z) = (x \oplus y) \oplus z$
 - (iii) $x \oplus e = x$
 - (iv) $x \oplus (\ominus(x)) = e$
 - (v) $x \leq y$ implies $x \oplus z \leq y \oplus z$.
- $(W, \leq, \oplus, \ominus, e)$ is an extended ordered Abelian group (OAG⁺) if in addition
 - (i) $\top \oplus x = \top, \perp \oplus x = \perp$ for all $x, \ominus(\top) = \perp, \ominus(\perp) = \top$.
 - (ii) If x, y are non extremal, then $x \oplus y$ is non extremal.

Clearly, our concern is to find an OAG⁺, with $W = [-1, 1]$, $\top = 1, \perp = -1, \ominus = -$, and \oplus corresponds to our operation \oplus .

Definition 8. (i) An isomorphism of an OAG (OAG⁺) $\mathbf{W} = (W, \leq, \oplus, \ominus, e)$ onto an OAG (OAG⁺) $\mathbf{W}' = (W', \leq', \oplus', \ominus', e')$ is a one-to-one mapping ϕ from W onto W' preserving the structure, i.e. such that

- (i) $\phi(x \oplus y) = \phi(x) \oplus' \phi(y)$
- (ii) $\phi(\ominus x) = \ominus' \phi(x)$

- (iii) $\phi(e) = e'$
- (iv) $x \leq y$ iff $\phi(x) \leq' \phi(y)$.
- (ii) \mathbf{W} is a substructure of \mathbf{W}' if $W \subseteq W'$ and the structure of \mathbf{W} is the restriction of the structure of \mathbf{W}' to W , i.e. $x \oplus y = x \oplus' y$, $\ominus x = \ominus' x$, $e = e'$, and $x \leq y$ iff $x \leq' y$, for all $x, y \in W$.
- (iii) An isomorphic embedding of \mathbf{W} into \mathbf{W}' is an isomorphism of \mathbf{W} onto a substructure of \mathbf{W}' .

Definition 9. (i) An OAG \mathbf{W} is dense if there is no least positive element, i.e. an element $x \in W$ such that $x > e$, and there is no $y \in W$ such that $e < y < x$.

(ii) An OAG \mathbf{W} is completely ordered if each non empty bounded $X \subseteq W$ has a least upper bound.

Obviously, $(] - 1, 1[, \leq, \oplus, -, 0)$ is dense and completely ordered, the same holds if the interval is closed.

Theorem 1. If \mathbf{W} is a completely ordered and dense OAG, then it is isomorphic to $(\mathbb{R}, \leq, +, -, 0)$.

The same result holds if \mathbf{W} is an OAG⁺ and if \mathbb{R} is replaced by $\overline{\mathbb{R}} := \mathbb{R} \cup \{-\infty, \infty\}$.

This shows that necessarily, \oplus has the following form:

$$x \oplus y = \phi^{-1}[\phi(x) + \phi(y)] \tag{5}$$

where $\phi : [-1, 1] \rightarrow \overline{\mathbb{R}}$ is one-to-one, odd, increasing, and satisfies $\phi(0) = 0$. Clearly, ϕ restricted to $[0, 1]$ is the additive generator of a strict t-conorm (see Section 2), and moreover, \oplus is a uninorm with $e = \frac{1}{2}$ and additive generator ϕ , up to a rescaling on $[0, 1]$ (see Section 2). These results were shown directly in [11].

Let us turn to the case of \otimes . If we impose distributivity of \otimes w.r.t. \oplus (called **R8**), then necessarily \otimes obeys the rule of sign of the usual product, i.e., for any $x, y \geq 0$, $(-x) \otimes y = -(x \otimes y)$. Indeed,

$$0 = (x \oplus (-x)) \otimes y = (x \otimes y) \oplus ((-x) \otimes y)$$

which entails $(-x) \otimes y = -(x \otimes y)$. This case corresponds to ordered rings and fields (see Fuchs [6]). Then \otimes is not monotone on $[-1, 1]^2$, and is uniquely determined by its values on $[0, 1]^2$, where it is a t-norm T . In summary, under **R1, R2, R3, R5** and **R8**, \otimes has the following form:

$$x \otimes y = \text{sign}(x \cdot y)T(|x|, |y|),$$

for some t-norm T , and

$$\text{sign}(x) := \begin{cases} 1, & \text{if } x > 0 \\ -1, & \text{if } x < 0 \\ 0, & \text{if } x = 0. \end{cases}$$

If distributivity is not needed, nothing prevents us from imposing monotonicity of \otimes on the whole domain $[-1, 1]^2$ (called **R5'**). Then, if we impose in addition $(-1) \otimes x = x$ for all $x \leq 0$ (called **R6'**), up to a rescaling in $[0, 1]$, \otimes is a nullnorm with $a = 1/2$, since \otimes is associative, commutative, non decreasing, and -1 is neutral on $[-1, 0]^2$, 1 is neutral on $[0, 1]^2$. In summary, under **R1**, **R2**, **R5'**, **R6** and **R6'**, \otimes has the following form:

$$x \otimes y = \begin{cases} T(x, y), & \text{if } x, y \geq 0 \\ S(x + 1, y + 1) - 1, & \text{if } x, y \leq 0 \\ 0, & \text{else} \end{cases}$$

for some t-norm T and t-conorm S .

4 Minimum and maximum on symmetrized linearly ordered sets

The previous section has shown that except for strict t-conorms, there is no way to build pseudo-addition fulfilling requirements **R1**, **R2**, **R3**, **R4**, and **R7**. Hence extending the maximum on $[-1, 1]$ in this way is not possible. However, we will show that this is in fact almost possible. Also, since our construction works on any linearly ordered set, this section addresses the construction of aggregation operators on ordinal bipolar scales.

We consider a linearly ordered set (L^+, \leq) , with bottom and top denoted $\mathbb{0}, \mathbb{1}$ respectively, and we define $L := L^+ \cup L^-$, where L^- is a reversed copy of L^+ , i.e. for any $a, b \in L^+$, we have $a \leq b$ iff $-b \leq -a$, where $-a, -b$ are the copies of a, b in L^- .

Our aim is to define extensions of minimum and maximum operators on L , denoted \oplus, \otimes and called *symmetric minimum* and *symmetric maximum*, in the same spirit as above. Specifically, we should require among others:

- (C1) \oplus, \otimes coincide with \vee, \wedge respectively on L^+
- (C2) \oplus, \otimes are associative and commutative on L .
- (C3) $-a$ is the symmetric of a , i.e. $a \oplus (-a) = \mathbb{0}$.
- (C4) $-(a \oplus b) = (-a) \oplus (-b)$, $-(a \otimes b) = (-a) \otimes b$, $\forall a, b \in L$.

Conditions **C1** and **C2** replace requirements **R1** to **R4** above, while condition **C3** is requirement **R7**. Condition **C4** tells that \oplus, \otimes should behave like addition and product on real numbers. The following result shows that this task is impossible [10].

Proposition 2. *We consider conditions (C1), (C3), (C4), and denote by (C4+) condition (C4) when a, b are restricted to L^+ . Then:*

- (1) *Conditions (C1) and (C3) implies that associativity cannot hold for \oplus .*
- (2) *Under (C1) and (C4+), $\mathbb{0}$ is neutral for \oplus . If we require in addition associativity, then $|a \oplus (-a)| \geq |a|$. Further, if we require isotonicity of \oplus , then $|a \oplus (-a)| = |a|$.*

In [7], the following definitions for \oplus, \otimes were proposed.

$$a \oplus b := \begin{cases} -(|a| \vee |b|) & \text{if } b \neq -a \text{ and } |a| \vee |b| = -a \text{ or } = -b \\ \mathbb{0} & \text{if } b = -a \\ |a| \vee |b| & \text{else.} \end{cases} \quad (6)$$

Except for the case $b = -a$, $a \oplus b$ equals the absolutely larger one of the two elements a and b .

$$a \otimes b := \begin{cases} -(|a| \wedge |b|) & \text{if } \text{sign } a \neq \text{sign } b \\ |a| \wedge |b| & \text{else.} \end{cases} \quad (7)$$

The absolute value of $a \otimes b$ equals $|a| \wedge |b|$ and $a \otimes b < \mathbb{0}$ iff the two elements a and b have opposite signs¹. Both operators are represented on Figure 1. These

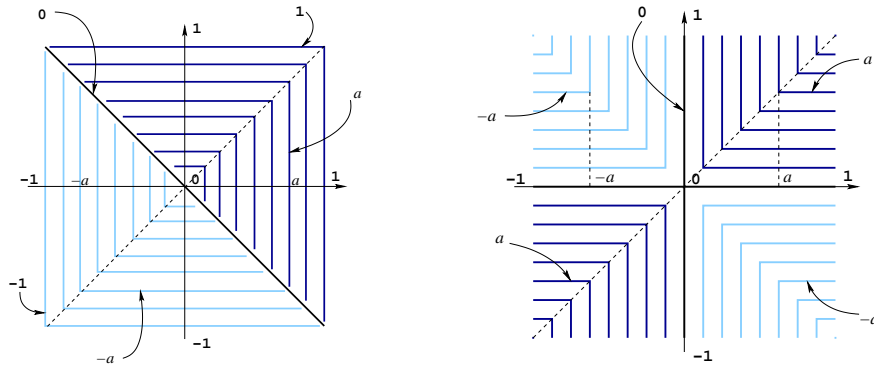

Fig. 1. Constant level curves of the symmetric maximum (left) and minimum (right)

operators have the following properties [10].

Proposition 3. *The structure (L, \oplus, \otimes) has the following properties.*

- (i) \oplus and \otimes fulfil conditions **C1**, **C3** and **C4**.
- (ii) $\mathbb{1}$ (resp. $\mathbb{0}$) is the unique absorbant element of \oplus (resp. \otimes);
- (iii) \oplus is associative for any expression involving a_1, \dots, a_n , $a_i \in L$, such that $\bigvee_{i=1}^n a_i \neq -\bigwedge_{i=1}^n a_i$.
- (iv) \otimes is associative on L .
- (v) \otimes is distributive w.r.t \oplus in L^+ and L^- separately.
- (vi) \otimes is isotone, i.e. $a \leq a', b \leq b'$ implies $a \otimes b \leq a' \otimes b'$.

The following result [10] shows that there is no “better” definition of \oplus under the given conditions.

¹ As in Section 3, one may impose as well non-decreasingness of \otimes on $[-\mathbb{1}, \mathbb{1}]$, making \otimes a nullnorm.

Proposition 4. *Under conditions (C1), (C3) and (C4), no operation is associative on a larger domain than \otimes as given by (6).*

The problem of non associativity may be a severe limitation if \otimes is used as a group operation to perform computation, like $\otimes_{i=1}^n a_i$. To overcome this difficulty, Grabisch has proposed several *computation rules* [10], which amount to eliminate situations where non associativity occurs, as given in Prop. 3. We denote them by $\langle \cdot \rangle$.

(i) The *splitting rule* $\langle \cdot \rangle_{\pm}^+$, splitting positive and negative terms:

$$\langle \otimes_{i=1}^n a_i \rangle_{\pm}^+ := \left(\otimes_{a_i \geq 0} a_i \right) \otimes \left(\otimes_{a_i < 0} a_i \right).$$

(ii) The *strong rule* $\langle \cdot \rangle_0$, cancelling maximal opposite terms successively until condition (iii) in Prop. 3 is satisfied. Formally,

$$\langle \otimes_{a_i \in A} a_i \rangle_0 := \otimes_{a_i \in A \setminus \bar{A}} a_i,$$

with the convention that $\otimes_{\emptyset} a_i := \mathbb{O}$, and $A := a_1, \dots, a_n$, while $\bar{A} := \bar{a}_1, \dots, \bar{a}_{2k}$ is the sequence of pairs of maximal opposite terms.

(iii) The *weak rule* $\langle \cdot \rangle_{=}$, cancelling maximal opposite terms as before, but with duplicates, i.e. the set \bar{A} contains in addition all duplicates of maximal opposite terms.

Taking for example $L = \mathbb{Z}$ and the sequence of numbers 3, 3, 3, 2, 1, 0, -2, -3, -3, for which associativity does not hold, the result for splitting rule is 0, while we have:

$$\begin{aligned} \langle 3 \otimes 3 \otimes 3 \otimes 2 \otimes 1 \otimes 0 \otimes -2 \otimes -3 \otimes -3 \rangle_0 &= 3 \otimes 2 \otimes 1 \otimes 0 \otimes -2 = 3 \\ \langle 3 \otimes 3 \otimes 3 \otimes 2 \otimes 1 \otimes 0 \otimes -2 \otimes -3 \otimes -3 \rangle_{=} &= 1 \otimes 0 = 1. \end{aligned}$$

The symmetric maximum with the strong rule coincides with the limit of some family of uninorms proposed by Mesiar and Komorniková [22].

We give several simple properties of these computation rules.

Lemma 1. *All computation rules satisfy the following boundary property for any sequence a_1, \dots, a_n*

$$\bigwedge_{i=1}^n a_i \leq \langle \otimes_{i=1}^n a_i \rangle \leq \bigvee_{i=1}^n a_i.$$

Lemma 2. *The rules $\langle \cdot \rangle_{\pm}^+$ and $\langle \cdot \rangle_0$ are isotone, i.e. they satisfy*

$$a_i \leq a'_i, \quad i = 1, \dots, n \text{ implies } \langle \otimes_{i=1}^n a_i \rangle \leq \langle \otimes_{i=1}^n a'_i \rangle.$$

Computation rule $\langle \cdot \rangle_=\$ is not isotone, as shown by the following example: take the sequence $-3, 3, 1$ in \mathbb{Z} . Applying the weak rule leads to 1. Now, if 1 is raised to 3, the result becomes \mathbb{O} .

The sequence a_1, \dots, a_n in L is said to be a *cancelling sequence for the rule* $\langle \cdot \rangle$ if $\langle \bigotimes_{i=1}^n a_i \rangle = \mathbb{O}$. We denote by $\mathcal{O}_{\langle \cdot \rangle}$ the set of cancelling sequences of $\langle \cdot \rangle$.

We say that computation rule $\langle \cdot \rangle_1$ is more *discriminating* than rule $\langle \cdot \rangle_2$ if $\mathcal{O}_{\langle \cdot \rangle_1} \subset \mathcal{O}_{\langle \cdot \rangle_2}$.

Lemma 3.

$$\mathcal{O}_{\langle \cdot \rangle_0} \subset \mathcal{O}_{\langle \cdot \rangle_=} \subset \mathcal{O}_{\langle \cdot \rangle_{\pm}}.$$

5 Separable operators

We consider here non necessarily associative operators M , in the spirit of means. We assume in this section that the underlying scale is $[-1, 1]$, otherwise specified. We denote by n the number of arguments of M .

A simple way to build bipolar aggregation operators is the following. Let M^+, M^- be given aggregation operators on $[0, 1]$. M^+ defines the aggregation for positive values, while M^- defines the aggregation of negative values:

$$M(x) = M^+(x) \text{ if } x \geq 0, \quad M(x) = -M^-(-x) \text{ if } x \leq 0.$$

For any $x \in [-1, 1]^n$, we define $x^+ := x \vee 0$ and $x^- := (-x)^+$. Note that $x = x^+ - x^-$, which suggests the following construction:

$$M(x) := \phi(M^+(x^+), M^-(x^-)), \quad \forall x \in [-1, 1]^n, \tag{8}$$

where ϕ is a *pseudo-difference*, defined as follows.

Definition 10. Let S be a *t-conorm*.

(i) The S -difference $\overset{S}{-}$ is defined by

$$a \overset{S}{-} b := \inf\{c \mid S(b, c) \geq a\}$$

for any (a, b) in $[0, 1]^2$.

(ii) The pseudo-difference associated to S is defined by

$$a \ominus_S b := \begin{cases} a \overset{S}{-} b, & \text{if } a \geq b \\ -(b \overset{S}{-} a), & \text{if } a \leq b \\ 0, & \text{if } a = b \end{cases}$$

Two simple particular cases are with $S = \vee$ and $S = S_L$. Then for any $a, b \in [-1, 1]$

$$a \ominus_{\vee} b = a \otimes (-b), \quad a \ominus_L b = a - b,$$

as it can be easily checked. If S is a strict t-norm with additive generator s , then

$$a \ominus_S b = g^{-1}(g(a) - g(b)),$$

with $g(x) = s(x)$ for $x \geq 0$, and $g(x) = -s(-x)$ for $x \leq 0$ (see [11]).

A bipolar aggregation operator defined by Eq. (8) is called *separable*.

If $M^+ = M^-$ is a strict t-conorm S with generator s , and \ominus_S is taken as pseudo-difference, we recover the construction of Section 3. Indeed, taking $n = 2$ (sufficient since associative), and g being the generator of \ominus_S :

$$\begin{aligned} M(x, y) &= S(x^+, y^+) \ominus_S S(x^-, y^-) \\ &= g^{-1}(g(S(x^+, y^+)) - g(S(x^-, y^-))) \\ &= g^{-1}(g(x^+) + g(y^+) - g(x^-) - g(y^-)) \\ &= g^{-1}(g(x) + g(y)) \end{aligned}$$

which is Eq. (5), and indeed g is odd, strictly increasing, and $g(0) = 0$.

An interesting case is when M^+, M^- are integral-based operators, such as the Choquet or Sugeno integrals (see definitions in Section 2). Applying (8) with suitable pseudo-differences, we recover various definitions of integrals for real-valued functions. Specifically, let us take M^+, M^- to be Choquet integrals with respect to capacities μ^+, μ^- , and ϕ is the usual difference $\ominus_{\mathbf{L}}$. Then:

- Taking $\mu^+ = \mu^-$ we obtain the *symmetric Choquet integral* [4] or Šipoš integral [27]:

$$\check{C}_\mu(x) := C_\mu(x^+) - C_\mu(x^-).$$

- Taking $\mu^- = \overline{\mu^+}$ we obtain the *asymmetric Choquet integral* [4]:

$$C_\mu(x) := C_\mu(x^+) - C_{\overline{\mu}}(x^-).$$

- For the general case, we obtain what is called in decision making theory the *Cumulative Prospect Theory (CPT)* model.

$$\text{CPT}_{\mu^+, \mu^-}(x) := C_{\mu^+}(x^+) - C_{\mu^-}(x^-).$$

We consider now that M^+, M^- are Sugeno integrals, with respect to capacities μ^+, μ^- , and ϕ is the residuated difference associated to the maximum, i.e. $\phi(x, y) := x \otimes (-y)$. Then as above,

- Taking $\mu^+ = \mu^-$ we obtain the *symmetric Sugeno integral* [8]:

$$\check{S}_\mu(x) := S_\mu(x^+) \otimes (-S_\mu(x^-)).$$

- Taking $\mu^+ = \overline{\mu^-}$ we obtain the *asymmetric Sugeno integral* [7]:

$$\hat{S}_\mu(x) := S_\mu(x^+) \otimes (-S_{\overline{\mu}}(x^-)).$$

- For the general case, we obtain what corresponds to the CPT model in an ordinal version.

$$\text{OCPT}_{\mu^+, \mu^-}(x) := \mathcal{S}_{\mu^+}(x^+) \otimes (-\mathcal{S}_{\mu^-}(x^-)).$$

Note that the above development on Sugeno integral could have been done on any linearly ordered set L , provided L has enough structure so we can define conjugate capacities. For a general study of the Sugeno integral as well as symmetric and asymmetric versions on linearly ordered sets, see Denneberg and Grabisch [5].

6 Integral-based operators

Let us study the case of integral-based operators, and we will limit ourself to the Choquet and Sugeno integrals, which are the most representative.

As explained in Section 2, the Choquet integral can be defined as the “simplest” linear interpolation between vertices of $[0, 1]^n$. Extending the domain to $[-1, 1]^n$, let us try to keep a similar approach.

The basic ingredient of the interpolative view is that $\mathcal{C}_\mu(1_A, 0_{A^c}) = \mathcal{S}_\mu(1_A, 0_{A^c}) = \mu(A)$. Let us call *binary vectors* those of the form $(1_A, 0_{A^c})$. In the unipolar case, coordinates of binary vectors are the boundaries of the interval $[0, 1]$. In the bipolar case, apart boundaries, we should also consider 0, as this value plays a particular role. We thus consider *ternary vectors*, whose components are either 1, 0 or -1 . We denote them $(1_A, -1_B, 0_{(A \cup B)^c})$, which means that $x_i = 1$ if $i \in A$, $x_i = -1$ if $i \in B$, and 0 elsewhere. Obviously, $A \cap B = \emptyset$, so that the set of ternary vectors is obtained when the pair (A, B) belongs to $\mathcal{Q}([n]) := \{(A, B) \mid A, B \subseteq [n], A \cap B = \emptyset\}$. The basic idea is to produce an aggregation function F which coincides with a set of fixed quantities $v(A, B)$, for $(A, B) \in \mathcal{Q}([n])$. In order to define a monotone aggregation operator, we are led to the following definition.

Definition 11. [12, 14] *A (normalized) bicapacity v on $[n]$ is a function $v : \mathcal{Q}([n]) \rightarrow [-1, 1]$ satisfying $v(\emptyset, \emptyset) = 0$, $v([n], \emptyset) = 1$, $v(\emptyset, [n]) = -1$, and $v(A, B) \leq v(C, D)$ whenever $A \subseteq C$ and $B \supseteq D$.*

Applying the same interpolative approach between ternary vectors, we are led to the following (see details in [15]). Let us consider $x \in [-1, 1]^n$. Defining $N_x^+ := \{i \in [n] \mid x_i \geq 0\}$, $N_x^- := [n] \setminus N_x^+$, with similar considerations of symmetry, we obtain as linear interpolation:

$$F(x) = |x_{\sigma(1)}| F(1_{N_x^+}, -1_{N_x^-}, 0_{(N_x^+ \cup N_x^-)^c}) + \sum_{i=2}^n (|x_{\sigma(i)}| - |x_{\sigma(i-1)}|) F(1_{\{\sigma(i), \dots, \sigma(n)\} \cap N_x^+}, -1_{\{\sigma(i), \dots, \sigma(n)\} \cap N_x^-}, 0_{\{\sigma(i), \dots, \sigma(n)\}^c})$$

where σ is a permutation on $[n]$ such that $|x_{\sigma(1)}| \leq \dots \leq |x_{\sigma(n)}|$. This expression is the Choquet integral of $|x|$ w.r.t. a set function $\nu_{N_x^+}$ defined by:

$$\nu_{N_x^+}(A) := F(1_{A \cap N_x^+}, -1_{A \cap N_x^-}, 0_{A^c}).$$

Recalling that $F(1_A, -1_B, 0_{(A \cup B)^c}) =: v(A, B)$, we finally come up with the following definition.

Definition 12. [13] Let v be a bicapacity and $x \in [-1, 1]^n$. The Choquet integral of x w.r.t v is given by

$$\mathcal{C}_v(x) := \mathcal{C}_{\nu_{N_x^\pm}}(|x|)$$

where $\nu_{N_x^\pm}$ is a set function on $[n]$ defined by

$$\nu_{N_x^\pm}(C) := v(C \cap N_x^+, C \cap N_x^-),$$

and $N_x^+ := \{i \in [n] \mid x_i \geq 0\}$, $N_x^- = [n] \setminus N_x^+$.

When there is no fear of ambiguity, we drop subscript x in N_x^+, N_x^- .

It is shown in [13] that if the bicapacity v has the form $v(A, B) := \mu^+(A) - \mu^-(B)$ for all $(A, B) \in \mathcal{Q}([n])$, where μ^+, μ^- are capacities, then $\mathcal{C}_v(x) = \text{CPT}_{\mu^+, \mu^-}(x)$, for all $x \in [-1, 1]^n$. Hence the Choquet integral based on a bicapacity encompasses the CPT model, and thus symmetric and asymmetric Choquet integrals.

By analogy, a definition can be proposed for the Sugeno integral w.r.t a bicapacity:

$$\mathcal{S}_v(x) := \mathcal{S}_{\nu_{N_x^\pm}}(|x|)$$

with the same notations as above. However, since $\nu_{N_x^\pm}$ may assume negative values, it is necessary to extend the definition of Sugeno integral as follows:

$$\mathcal{S}_\nu(x) := \left\langle \bigotimes_{i=1}^n [x_{\sigma(i)} \otimes \nu(\{\sigma(i), \dots, \sigma(n)\})] \right\rangle_{-}^{+}$$

where $x \in [0, 1]^n$, ν is any real-valued set function such that $\nu(\emptyset) = 0$, and σ is a permutation on $[n]$ such that x becomes non decreasing. $\langle \cdot \rangle_{-}^{+}$ indicates the splitting rule defined in Section 4. Then, the Sugeno integral for bicapacities can be rewritten as

$$\mathcal{S}_v(x) = \left\langle \bigotimes_{i=1}^n \left[|x_{\sigma(i)}| \otimes v(\{\sigma(i), \dots, \sigma(n)\} \cap N^+, \{\sigma(i), \dots, \sigma(n)\} \cap N^-) \right] \right\rangle_{-}^{+}. \quad (9)$$

This formula is similar to the one proposed by Greco *et al.* [18].

The following result shows that the Sugeno integral w.r.t. a bicapacity encompasses the OCPT model.

Proposition 5. Let v be a bicapacity of the form $v(A, B) := \mu^+(A) \otimes (-\mu^-(B))$, where μ^+, μ^- are capacities. Then the Sugeno integral reduces to

$$\mathcal{S}_v(x) := \mathcal{S}_{\mu^+}(x^+) \otimes (-\mathcal{S}_{\mu^-}(x^-)) = \text{OCPT}_{\mu^+, \mu^-}(x), \quad \forall x \in [-1, 1]^n.$$

Note that if $\mu^+ = \mu^-$ (v could then be called a \vee -symmetric bicapacity), then \mathcal{S}_v is the symmetric Sugeno integral.

Proof. Denote by σ a permutation on $[n]$ such that $|x|$ is non-decreasing, and put $A_{\sigma(i)} := \{\sigma(i), \dots, \sigma(n)\}$. Since x^+, x^-, μ^+, μ^- are non negative, we have

$$\begin{aligned}\mathcal{S}_{\mu^+}(x^+) &= \bigvee_{i=1}^n \left[x_{\sigma(i)}^+ \wedge \mu^+(A_{\sigma(i)} \cap N^+) \right] \\ \mathcal{S}_{\mu^-}(x^-) &= \bigvee_{i=1}^n \left[x_{\sigma(i)}^- \wedge \mu^-(A_{\sigma(i)} \cap N^-) \right].\end{aligned}$$

Using the definition of v , we get

$$\mathcal{S}_v(x) = \left\langle \bigotimes_{i=1}^n \left[|x_{\sigma(i)}| \otimes [\mu^+(A_{\sigma(i)} \cap N^+) \otimes (-\mu^-(A_{\sigma(i)} \cap N^-))] \right] \right\rangle_{-}^+.$$

Due to the definition of $\langle \cdot \rangle_{-}^+$, we have to show that if $\mathcal{S}_{\mu^+}(x^+)$ is larger (resp. smaller) than $\mathcal{S}_{\mu^-}(x^-)$, then the maximum of positive terms is equal to $\mathcal{S}_{\mu^+}(x^+)$ and is larger in absolute value than the maximum of negative terms (resp. the maximum of absolute value of negative terms is equal to $\mathcal{S}_{\mu^-}(x^-)$ and is larger in absolute value than the maximum of positive terms).

Let us consider $\sigma(i) \in N^+$. Two cases can happen.

- if $\mu^+(A_{\sigma(i)} \cap N^+) > \mu^-(A_{\sigma(i)} \cap N^-)$, then the corresponding term reduces to $x_{\sigma(i)}^+ \otimes \mu^+(A_{\sigma(i)} \cap N^+)$. This term is identical to the i th term in $\mathcal{S}_{\mu^+}(x^+)$.
- if not, the i th term in $\mathcal{S}_v(x)$ reduces to $-x_{\sigma(i)}^+ \otimes \mu^-(A_{\sigma(i)} \cap N^-)$. Due to monotonicity of μ^+ , this will be also the case for all subsequent indices $\sigma(i+1), \dots, \sigma(i+k)$, provided they belong to N^+ . Moreover, assuming $\sigma(i+k+1) \in N^-$, we have

$$\begin{aligned}|x_{\sigma(i+k+1)}| \otimes \left[\mu^+(A_{\sigma(i+k+1)} \cap N^+) \otimes (-\mu^-(A_{\sigma(i+k+1)} \cap N^-)) \right] \\ = -|x_{\sigma(i+k+1)}| \otimes \mu^-(A_{\sigma(i+k+1)} \cap N^-) \\ \leq |x_{\sigma(j)}| \otimes \underbrace{\mu^-(A_{\sigma(j)} \cap N^-)}_{A_{\sigma(i+k+1)} \cap N^-}, \quad \forall j = i, \dots, i+k.\end{aligned}$$

Hence, in the negative part of $\mathcal{S}_v(x)$, the term in $\sigma(i+k+1)$ remains, while all terms in $\sigma(i), \dots, \sigma(i+k)$ are cancelled, and it coincides with the $(i+k+1)$ th term in $\mathcal{S}_{\mu^-}(x^-)$. On the other hand, in $\mathcal{S}_{\mu^+}(x^+) \otimes (-\mathcal{S}_{\mu^-}(x^-))$, the term in $\sigma(i)$ in $\mathcal{S}_{\mu^+}(x^+)$ is smaller in absolute value than the term in $\sigma(i+k+1)$ of $\mathcal{S}_{\mu^-}(x^-)$, so that the term in $\sigma(i)$ cannot be the result of the computation, and thus it can be discarded from $\mathcal{S}_{\mu^+}(x^+)$.

A similar reasoning can be done with $\sigma(i) \in N^-$. This proves that $\mathcal{S}_v(x)$ and $\mathcal{S}_{\mu^+}(x^+) \otimes (-\mathcal{S}_{\mu^-}(x^-))$ are identical.

7 Acknowledgments

The author acknowledges support from the COST Action 274 TARSKI. Parts of this work have been done in collaboration with B. de Baets and J. Fodor, participant to the same COST Action.

References

1. P. Benvenuti, R. Mesiar, and D. Vivona. Monotone set functions-based integrals. In E. Pap, editor, *Handbook of Measure Theory*, pages 1329–1379. Elsevier Science, 2002.
2. T. Calvo, B. De Baets, and J. Fodor. The functional equations of alsina and frank for uninorms and nullnorms. *Fuzzy Sets and Systems*, 101:15–24, 2001.
3. T. Calvo, G. Mayor, and R. Mesiar, editors. *Aggregation operators: new trends and applications*. Studies in Fuzziness and Soft Computing. Physica Verlag, 2002.
4. D. Denneberg. *Non-Additive Measure and Integral*. Kluwer Academic, 1994.
5. D. Denneberg and M. Grabisch. Measure and integral with purely ordinal scales. *J. of Mathematical Psychology*, 48:15–27, 2004.
6. L. Fuchs. *Partially Ordered Algebraic Systems*. Addison-Wesley, 1963.
7. M. Grabisch. Symmetric and asymmetric fuzzy integrals: the ordinal case. In *6th Int. Conf. on Soft Computing (Iizuka'2000)*, Iizuka, Japan, October 2000.
8. M. Grabisch. The symmetric Sugeno integral. *Fuzzy Sets and Systems*, 139:473–490, 2003.
9. M. Grabisch. The Choquet integral as a linear interpolator. In *10th Int. Conf. on Information Processing and Management of Uncertainty in Knowledge-Based Systems (IPMU 2004)*, pages 373–378, Perugia, Italy, July 2004.
10. M. Grabisch. The Möbius function on symmetric ordered structures and its application to capacities on finite sets. *Discrete Mathematics*, 287(1-3):17–34, 2004.
11. M. Grabisch, B. De Baets, and J. Fodor. The quest for rings on bipolar scales. *Int. J. of Uncertainty, Fuzziness, and Knowledge-Based Systems*, 12(4):499–512, 2004.
12. M. Grabisch and Ch. Labreuche. Bi-capacities for decision making on bipolar scales. In *EUROFUSE Workshop on Informations Systems*, pages 185–190, Varenna, Italy, September 2002.
13. M. Grabisch and Ch. Labreuche. Fuzzy measures and integrals in MCDA. In J. Figueira, S. Greco, and M. Ehrgott, editors, *Multiple Criteria Decision Analysis*, pages 563–608. Kluwer Academic Publishers, 2004.
14. M. Grabisch and Ch. Labreuche. Bi-capacities. Part I: definition, Möbius transform and interaction. *Fuzzy Sets and Systems*, 151:211–236, 2005.
15. M. Grabisch and Ch. Labreuche. Bi-capacities: towards a generalization of Cumulative Prospect Theory. *J. of Mathematical Psychology*, submitted.
16. M. Grabisch, T. Murofushi, and M. Sugeno. *Fuzzy Measures and Integrals. Theory and Applications (edited volume)*. Studies in Fuzziness. Physica Verlag, 2000.
17. M. Grabisch, S. A. Orlovski, and R. R. Yager. Fuzzy aggregation of numerical preferences. In R. Słowiński, editor, *Fuzzy Sets in Decision Analysis, Operations Research and Statistics*, The Handbooks of Fuzzy Sets Series, D. Dubois and H. Prade (eds), pages 31–68. Kluwer Academic, 1998.
18. S. Greco, B. Matarazzo, and R. Slowinski. Bipolar Sugeno and Choquet integrals. In *EUROFUSE Workshop on Informations Systems*, pages 191–196, Varenna, Italy, September 2002.
19. P. Hájek. *Metamathematics of fuzzy logic*. Kluwer Academic Publishers, 1998.
20. P. Hájek, T. Havránek, and R. Jiroušek. *Uncertain Information Processing in Expert Systems*. CRC Press, 1992.
21. E. P. Klement, R. Mesiar, and E. Pap. *Triangular Norms*. Kluwer Academic Publishers, Dordrecht, 2000.

22. R. Mesiar and M. Komorniková. Triangular norm-based aggregation of evidence under fuzziness. In B. Bouchon-Meunier, editor, *Aggregation and Fusion of Imperfect Information*, Studies in Fuzziness and Soft Computing, pages 11–35. Physica Verlag, 1998.
23. T. Murofushi and M. Sugeno. Fuzzy t-conorm integrals with respect to fuzzy measures : generalization of Sugeno integral and Choquet integral. *Fuzzy Sets & Systems*, 42:57–71, 1991.
24. W. Sander and J. Siedekum. Multiplication, distributivity and fuzzy integral I. *Kybernetika*, 41:397–422, 2005.
25. W. Sander and J. Siedekum. Multiplication, distributivity and fuzzy integral II. *Kybernetika*, 41:469–496, 2005.
26. W. Sander and J. Siedekum. Multiplication, distributivity and fuzzy integral III. *Kybernetika*, 41:497–518, 2005.
27. J. Šipoš. Integral with respect to a pre-measure. *Math. Slovaca*, 29:141–155, 1979.
28. R. Yager and A. Rybalov. Uninorm aggregation operators. *Fuzzy Sets and Systems*, 80:111–120, 1996.