

## SF<sub>6</sub> Dielectric Behaviour in a High Voltage Circuit Breaker at Low Temperature under Lightning Impulses

F. Buret

CEGELY - URA CNRS 829  
Ecole Centrale de Lyon  
69131 Ecully, France

A. Beroual, Member, IEEE

**Abstract** - This work concerns the study of the dielectric and thermodynamic behaviour of SF<sub>6</sub> in a 145 kV circuit breaker subjected to lightning impulse voltages in both polarities at temperatures varying from ambient (20°C) to -45°C. The filling of the circuit breaker with SF<sub>6</sub> is carried out at the reference point: T = 15°C, P = 6 bars abs. and d = 39.6 kg/m<sup>3</sup>.

Devices allowing to detect the appearance of local condensation of SF<sub>6</sub> and to identify the breakdown between the circuit-breaker contacts and the flashover outside the circuit-breaker, are presented.

The experimental results show a general tendency to a decrease in the U<sub>50%</sub> voltage when the temperature is decreased at constant density (a decrease by about 5% when the temperature was decreased from +20°C to -25°C). Such a variation would not have a significant influence in industrial practice. Even if this variation is very weak, it also appears from the obtained results that the gas density is not the only parameter which has an influence on the electric strength of the gas. However, to compare results at different temperatures, it would be better to make it at constant density and not at constant pressure, to avoid the dependency of the ratio (E/N) on N (where E is the electric strength and N the density). On the other hand, it seems that the presence of the liquid in the circuit breaker is not a penalizing parameter.

The distribution of the electric field corresponding to the geometrical configuration of the studied circuit-breaker is also presented.

95 SM 495-2 PWRD A paper recommended and approved by the IEEE Switchgear Committee of the IEEE Power Engineering Society for presentation at the 1995 IEEE/PES Summer Meeting, July 23-27, 1995, Portland, OR. Manuscript submitted June 29, 1994; made available for printing April 27, 1995.

### I. INTRODUCTION

It is well known that sulfurhexafluoride (SF<sub>6</sub>) has excellent insulating properties such as high interrupting capacity and high dielectric strength. It is more and more substituted for air and insulating oils in electrical equipments. These interesting properties permit a significant reduction in the dimensions of apparatus in which it is used as an insulating medium.

Moreover, it is non toxic and unflammable. The low viscosity of SF<sub>6</sub> coupled with its high density engenders good dissipation qualities. However, it presents some inconveniences such as liquification at pressures lower than those corresponding to air and nitrogen, especially if it is used at high pressures as is the actual tendency in industrial practice.

A property such as increased interrupting capacity often requires working under high pressure conditions (more than 6 bars abs.) with attendant risks of partial condensation at climatic conditions (ambient temperatures). Obviously, partial condensation leads to a decrease of gas density and thus a lower voltage withstand capability. It must however be pointed out that in industrial practice, the security margin of modern electrical apparatus is relatively reduced. Hence, a small reduction in the dielectric strength of SF<sub>6</sub> due to a temperature effect, even without condensation, could have great importance in the design and manufacture of HV apparatus intended to work under extreme climatic conditions (up to -45°C).

The subject of this paper is to present results concerning the dielectric strength of a 145 kV circuit breaker SF<sub>6</sub>, subjected to lightning impulse voltages in both polarities at temperatures varying from ambient (20°C) to -45°C. The distribution of the electric field in the region of the contacts of the circuit-breaker is computed by a BEM package. We also present devices that we realised and which allow us to detect the appearance of local condensation of SF<sub>6</sub> and to identify the breakdown between the circuit breaker contacts and the flashover outside the circuit breaker.

## II. EXPERIMENTAL ARRANGEMENTS

The experimental set-up consists of an impulse H.V. generator (Marx multiplier arrangement 1 MV - 50 kJ), a voltage capacitive divider and the test circuit breaker. The inter-contact distance was 20 mm.

The SF<sub>6</sub> high voltage circuit breaker (145 kV) is introduced in a refrigerating enclosure similar to the one described in a previous work [1]. This enclosure allows us to conduct dielectric tests under lightning impulse voltages in a temperature varying from the ambient (20 °C) to -45 °C. The low temperatures are produced by the expansion of CO<sub>2</sub> (Fig. 1).

A numeric manometer allows us to measure the gas pressure with a precision of 1%. Thermal sensors (platine resistor PT100) connected to a micro-computer measure the temperatures at different points inside the circuit breaker at each minute. The filling of the circuit breaker with SF<sub>6</sub> is carried out at the reference point: T = 15°C, P = 6 bars abs. and d = 39.6 kg/m<sup>3</sup>.

The tests at ambient and low temperatures were conducted for an electrode gap of 20 mm in the same circuit breaker. The determination of the breakdown voltage 50% was effected by the up and down method on a serie of 30 impulses. A numerical transient recorder (Tek 390 AD) and an oscilloscope were used to measure and to visualize the applied voltage.

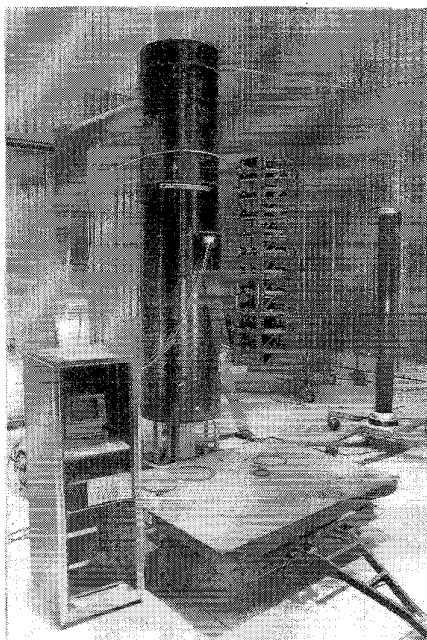

Fig. 1. Photograph of the experimental arrangement.

The appearance of a liquid phase, resulting from a partial condensation of SF<sub>6</sub>, is detected with a liquid phase detectors inside the circuit breaker.

On the other hand, because the circuit breaker is set-up in an opaque enclosure, it is difficult to distinguish a breakdown between the contacts of the circuit breaker (which is also opaque) from a flashover on its external surface. That is why, we have used two identical arc detectors: one inside the circuit breaker for breakdown indication, the second outside for flashover signaling. In the following, we describe these two types of detectors.

### A. Liquid Phase Detector

The working principle of this detector is based on the variation of the refractive index of a medium when a change of state occurs (gas, liquid, solid) [2]. In our case, it concerns the transition SF<sub>6</sub> gas - SF<sub>6</sub> liquid. For SF<sub>6</sub> gas, this index  $n_g$  is practically equal to 1, whereas it is of  $n_l = 1.35$  for the liquid phase (LSF<sub>6</sub>). This index variation is detected using a device which consists of two optical fibres (PMMA): one transmitting and the other receiving. The amplitude of the transmitted light between these two fibres depends on the refractive index of the medium. When SF<sub>6</sub> droplets appear, the light rays emanating from the transmitting fibre are, for the most part, deviated outside the capture angle of the receiving fibre. The collected light intensity is obviously lower than that one observed in the previous case. When the fibres are partially immersed in the SF<sub>6</sub> liquid (LSF<sub>6</sub>), the behaviour is similar. As concerns the case in which the optical fibres are completely immersed in the LSF<sub>6</sub>, the amplitude of the collected light will be larger than that obtained in SF<sub>6</sub> gas ( $n_l = 1.35 > n_g = 1$ ;  $n_l$  and  $n_g$  are respectively the refractive indexes of LSF<sub>6</sub> and SF<sub>6</sub> gas).

The practical realisation of a such detector consists of two cases (blocs): a transmitter and a receptor.

- the transmitter case emits a light flux (transmitter HP 1502) the intensity of which can be regulated thanks to a potentiometer.

- the receiving case (Fig. 2) uses an HP 2502 circuit. It treats the light signal collected by the receiving fibre supplying an electric signal depending on its intensity. The latter is recorded thanks to a plotter.

In the absence of liquid phase, the system is polarised so as to give an electric signal situated at the middle of the output range (about 5 volts). The latter is defined as follows:

- the output level is high (8 volts) when the transmission is weak.

- the output level is low (2 volts) when the transmission is good.

This polarisation is obtained by regulating the intensity of the emitted light, the sensitivity of the receiving or the gap between fibres (typically some millimeters).

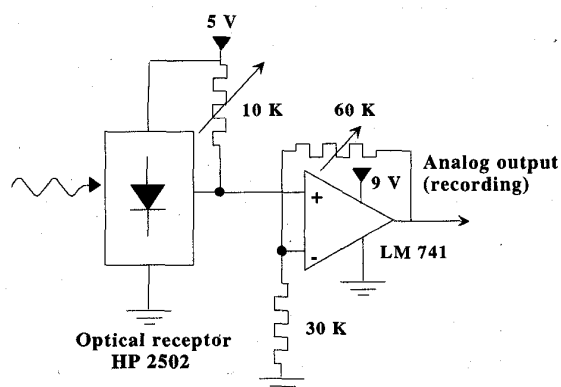

Fig. 2. Electronic diagram of the receptor block of the phase detector.

### B. Electrical Discharge Detector

Because the enclosure used to refrigerating of the circuit breaker is entirely opaque, it is difficult to localize the discharge appearance or to distinguish a breakdown between contacts of the circuit breaker (also opaque) from a flashover on its external surface. For this, we use two identical detectors: one inside the circuit breaker for breakdown indication, the second outside for flashover signalling (Fig. 3). In such application, the optoelectronic circuit also includes a flip-flop allowing the memorization and the visualization of any pulse produced by a discharge thanks to light emitting diodes. This detector consists of an optronic circuit and a fluorescent optical fibre which is the sensor, properly called. It is sensitive to an incident light flux in a well defined spectral range. A part of this flux is emitted in another range of frequencies on the axial direction. The spectral characteristics of both the exciting light flux and the emitted one depend on the nature of the dopers and the polymer used in the fibre core. These must be

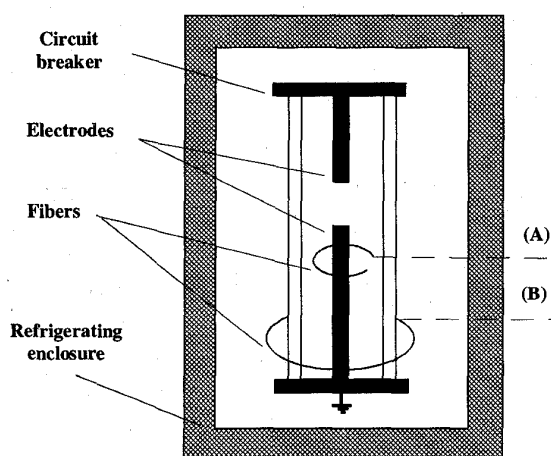

Fig. 3. Position of arc detectors inside (a) and outside (b) the SF<sub>6</sub> high voltage circuit breaker.

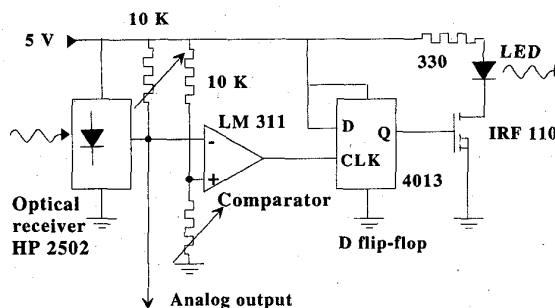

Fig. 4. Electronic diagram of the breakdown detector.

carefully controlled to optimize the method of detection. The efficiency of this reception-emission process depends on them. It is no greater than 4%.

On the other hand, this low effectiveness is compensated for by a large capture surface. Indeed, the light rays coming from any incident angle are collected on all lateral surfaces of the fibre, in contrast with classical multimode fibres. These only capture the light rays that arrive on one of its two extreme surfaces, with an incident angle less than  $i$  ( $\sin i = NA$ ,  $NA$  being the numerical aperture). Consequently, the captured light flux is sufficient to make this optical detector sensitive. The sensitivity of this optical detector increases with the length of the fluorescent fibre, within the limit of 1 m for the used model.

The detection fibre used (ref. OPTECTORON F202) re-emits mainly in the red frequencies. This choice is only justified by the sensitivity range of the optoelectronic receiver used (ref. HP 2502 Hewlett Packard), the maximum sensitivity of which is at 670 nm. The fibre, well polished at its extremities, is soldered to a PMMA transparent plastic fibre (ref. OPTECTORON CSQ 1000-01 : 10 m in length), which serves as a wave guide and permits the transmission of information at long distances, while ensuring a perfect electrical insulation. The dimensions of the fluorescent fibre depend on the site where it will be implemented, and the apparatus.

The detector circuit (Fig. 4) is based on an optical receiver (HP 2502). The electrical signal that it transmits is a function (nonlinear) of the incident flux. It can be stored directly on a transitory numerical recorder.

Fig. 5 gives some examples concerning breakdowns under lightning impulse voltages. We observe that, as soon as breakdown occurs (this corresponds to a rough drop in the voltage applied to the HV apparatus), the detector gives a signal. We notice a weak lag between the time detected by the optical detector and that given by the shape of the applied voltage. This is due to the fact that the discharge detector response (propagation time in the fibre = 50 ns) is shorter than the one given by the high voltage measurement (275 ns with the propagation time in the coaxial cable).

This devices can be extend to other applications as we discussed in previous work [3]. It detects not only the appearance of discharges but also localizes them. This is of

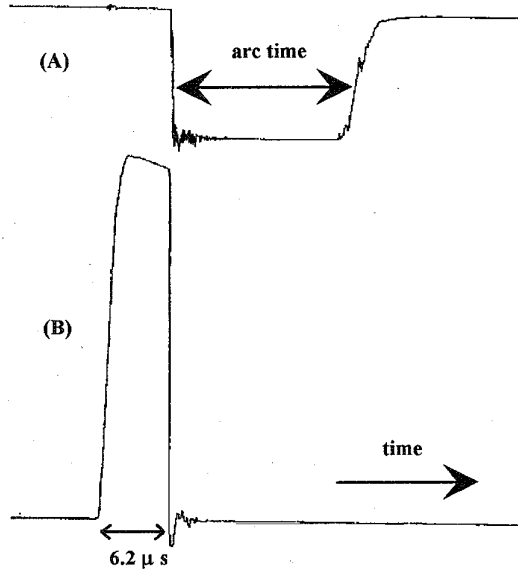

Fig. 5. Light signal (A) detected when an electric breakdown occurs under a positive lightning impulse of 518 kV max. (B) voltage recording.

great use in HV apparatus where the supervision of discharges is required.

### III. RESULTS AND DISCUSSION

#### A. Thermodynamic Behaviour

Figure 6 is an example of recordings obtained when the temperature is decreased from the ambient to  $-37^{\circ}\text{C}$ . When the temperature of the gas reaches  $-32^{\circ}\text{C}$  (absolute pressure 4.7 bars, density  $39.6 \text{ kg/m}^3$ ),  $\text{LSF}_6$  droplets appear. As we can remark it from the plot of  $\text{SF}_6$  absolute pressure versus temperature (Fig. 7) [4], this point corresponds to the liquid

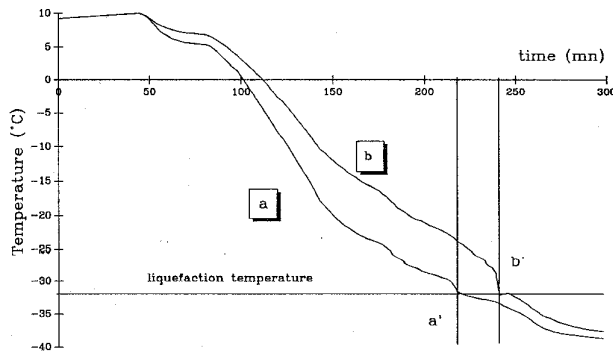

Fig. 6. Temperature of the upper cover (a) and at the bottom (b) of the circuit breaker versus the time when the temperature is decreased from  $9^{\circ}\text{C}$  to  $-37^{\circ}\text{C}$ . The vertical lines indicate the time when the liquid phase is detected at the upper cover (a') and at the bottom (b') of the circuit breaker.

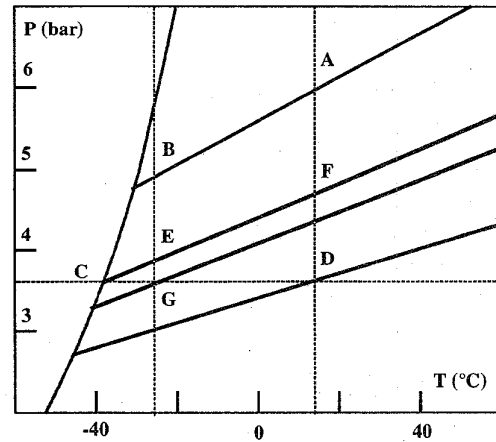

Fig. 7. Absolute pressure versus temperature with constant volume weight. The values corresponding to the represented points are reported on table 1.

phase transition.

The two temperature recordings are in conformity with expected results as per the set-up of test system. The structure of our refrigerating system is such that cold penetrates through the upper part of the circuit breaker. The condensation of the gas first appears in this region.  $\text{LSF}_6$  runs down the walls towards the bottom of the circuit breaker where the liquid phase detector is mounted.

Fig. 8 gives an example of the liquid detector output located at the bottom of the circuit breaker.

The recording shows the presence of the liquid phase which is characterized by peaks on the recording (Fig. 8). They correspond to a transitory improvement of the transmission. Indeed, the  $\text{LSF}_6$  first evaporates rapidly (Fig. 8 - region 1) when it reaches the bottom of the circuit breaker where the temperature is higher. As soon as the temperature near the detector is sufficiently low, the  $\text{LSF}_6$  begins to accumulate (Fig. 8 - region 2). Then, the transmission will be very reduced by the fact that the optical fibres are partially immersed. When the level of  $\text{LSF}_6$  is such that the fibres are completely covered (Fig. 8 - region 3), the transmission becomes better (signal at low level). The signal will remain at this level as long as the liquid phase exists.

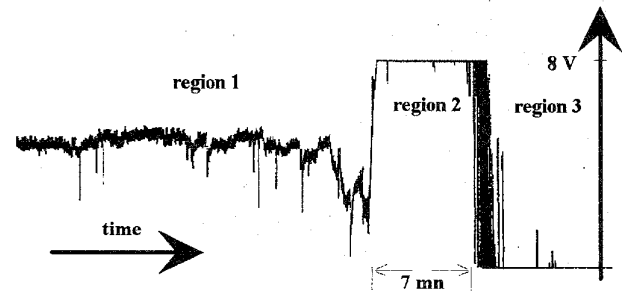

Fig. 8. Phase changing of  $\text{SF}_6$  when the temperature is decreased from the

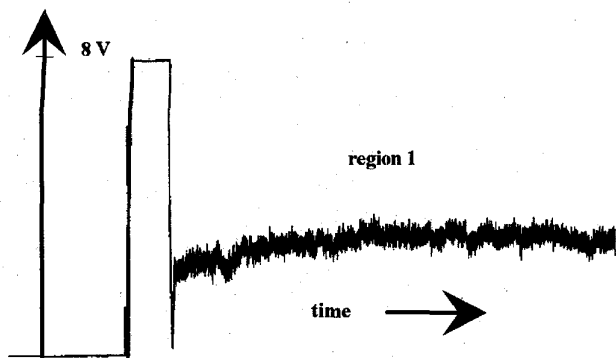

Fig. 9. Phase changing of  $\text{SF}_6$  when the temperature is increased from  $-37^\circ\text{C}$  to the ambient.

When the temperature is increased from  $-37^\circ\text{C}$  to the ambient, we observe an inverse phenomena, except for peaks (Fig. 9 - region 1). This is normal because the upper circuit breaker is more hot (no raining down) during the heating phase.

### B. Dielectric Tests

1) *Field Distribution*: Field computation of the studied configuration (circuit-breaker with a 20 mm contact gap) has been achieved by a software package based on BEM [5]: PHI3D. Fig. 10 gives the results of the computation i.e the electric field module on the surface. Maxima E-field appears on the upper arc contact. It is of 80 V/m for 1 volt potential. This gives an utilization factor value equal to 0.62. That is this value which we use in the following.

2) *Analyse of the Breakdown Voltages*: Table I summarizes the main points for which the measurements have been carried out. Note that the underlined  $U_{50\%}$  voltage values have not been obtained by direct measurements but

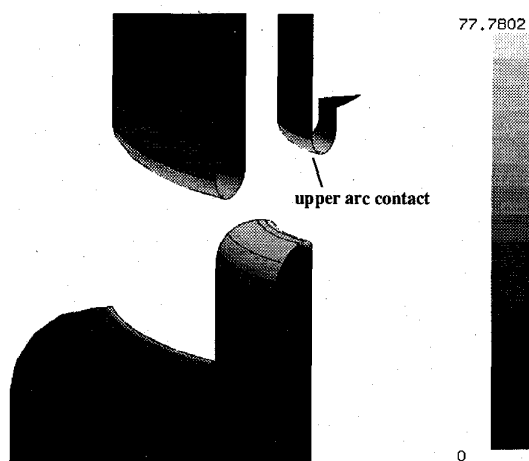

Fig. 10. Electric field module on the surface of the circuit-breaker contacts achieved by a BEM package; the inter-contact distance was 20 mm.

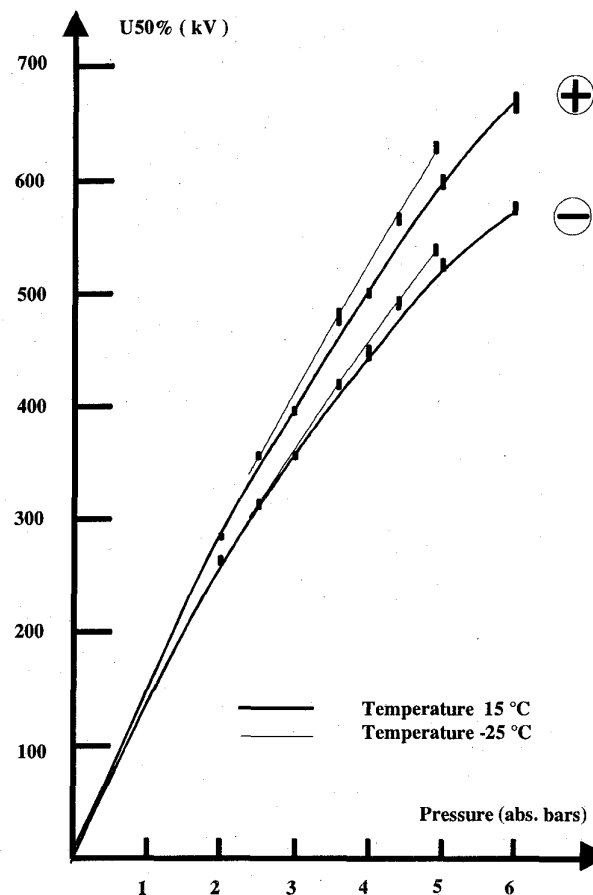

Fig. 11. Breakdown voltage  $U_{50\%}$  versus the absolute pressure at ambient ( $15^\circ\text{C}$  and  $-25^\circ\text{C}$ ).

deduced by extrapolation from Fig. 11.

Fig. 11 represents the characteristics  $U_{50\%}$  versus the pressure at ambient ( $T = +15^\circ\text{C}$  with a pressure varying from 2 to 6 bars absolute) and at  $-25^\circ\text{C}$  (pressure was varying from 2.5 to 4.9 bars abs.) for lightning impulse voltages. At  $-39^\circ\text{C}$  (Pabs. = 3.6 bars), we are in presence of  $\text{LSF}_6$  drops as it can be deduced from the diagram of the  $\text{SF}_6$  absolute pressure versus temperature, and observed by the liquid phase detector (Fig. 8). Point H represents the measurements which have been taken when the circuit breaker has regained ambient temperature conditions. It represents a verification point. The  $U_{50\%}$  values (point H) are entirely in conformity with the initial ones (point A).

The experimental points reported in table I can be discussed in regards to a constant gas density  $N$  (pressure and temperature variable) or a constant pressure (gas density and temperature variable).

When the gas density is constant ( $39.6 \text{ kg/m}^3$ ), the  $U_{50\%}$  values obtained at  $-25^\circ\text{C}$  (point B) are systematically lower than those measured at  $+15^\circ\text{C}$  (point A). It will be interesting to evaluate the voltage gradient versus the temperature ( $\text{Gr} =$

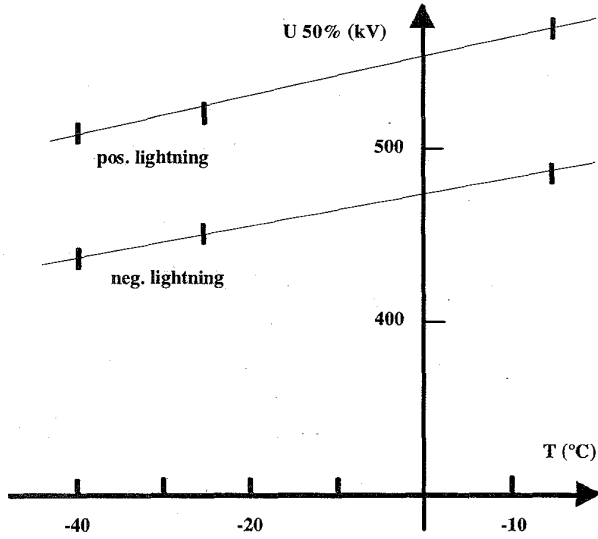

Fig. 12.  $U_{50\%}$  breakdown voltage versus temperature for a  $29.4 \text{ kg/m}^3$  gas density.

$\Delta U_{50\%} / \Delta T$  for a constant density).

Fig. 12 gives the distribution of the C, E and F points on

the characteristics  $U_{50\%} = f(T)$  for a gas density estimated to  $29.4 \text{ kg/m}^3$ .

The  $U_{50\%}$  values corresponding to A, B and C points are given with  $\pm 4 \text{ kV}$ . The voltage gradients  $Gr$ , with an average value of 1.1, are of the same range in comparison with points A and B. Note that point C corresponds to a thermodynamic state with presence of  $\text{LSF}_6$ . It appears that the dielectric withstand is not influenced by the presence of  $\text{LSF}_6$ . This withstand depends rather on the state of the vapor phase. A priori, there are no droplets on the contacts of the circuit breaker (point C). Indeed, no signal is indicated by the upper phase detector. However, we cannot be sure of this fact.

On the other hand, we remark (table 1), that the ratio  $(E/N)$  of the electric field  $E$  to the gas density  $N$  is higher for the positive impulse voltages than for the negative ones (whatever the temperature  $T$  and the gas pressure  $P$ ). So, the variation of the ratio  $(E/P)$  is more important than  $(E/N)$ .

To compare the results at different temperatures, it would be better to make it at constant density and not at constant pressure, to avoid the dependency of  $(E/N)$  with  $N$ . The comparison of results at constant pressure cannot be generalized. Indeed, the variation of the breakdown voltage  $U_{50\%}$  vs  $N$  is not linear and points must be compared either on the linear part of the curve  $U_{50\%}(N)$ , or on the non-linear ones.

TABLE I  
SUMMARY OF THE MAIN EXPERIMENTAL RESULTS.

	A	B	C	D	E	F	G	H
T (°C)	15	-25	-39	15	-25	15	-25	15
Pressure (bar)	6.0	4.9	3.6	3.6	3.85	4.55	3.6	6.0
Density ( $\text{kg/m}^3$ )	39.6	39.6	29.4	23	29.4	29.4	27.4	39.6
Liquid	No	No	Yes	No	No	No	No	No
$U_{50\%}$ Light. + (kV)	665	631	508	460	505	557	481	660
E+ (kV/cm)	536.3	508.9	409.7	371.0	407.2	449.2	387.9	
E/p + (kV/(cm.bar))	89.4	103.9	113.8	103.0	105.8	98.7	107.8	
E/N + ( $\text{kV.cm}^2$ )	13.5	12.9	13.9	16.1	13.85	15.3	14.1	
$U_{50\%}$ Light. - (kV)	577	539	438	400	440	496	418	574
E - (kV/cm)	465.3	434.7	353.2	322.6	354.6	400	337.1	
E/p - (kV/(cm.bar))	77.5	88.7	98.1	89.6	92.2	87.9	93.6	
E/N - ( $\text{kV.cm}^2$ )	11.8	11.0	12.0	14.0	12.0	13.6	12.3	

#### IV. CONCLUSION

Our experimental results confirm the previous ones [1] obtained with lower pressures, contrary to the results reported in [6] where no influence of the temperature has been noticed. Indeed, M. Landry et al. [1] have observed a decrease in the dielectric strength of 16 % when the temperature varied from +20°C to -50°C, at constant gas density. For W. Widl et al. [6] the only problem in the use of circuit breaker at low temperatures is a mechanical one.

It appears that the gas density is the main parameter as it is usually admitted, but not the only one. The influence of the temperature is weak (5% between ambient and -25°C). So, this variation would not have a significant influence in industrial practice.

#### V. ACKNOWLEDGMENT

This work was supported by the French Minister for Research and Technology (MRT) under the Contract number 88 F0 928. The authors wish to thank GEC ALSTHOM, MERLIN GERIN and EDF Companies for their help.

#### VI. REFERENCES

- [1] M. Landry and R. Jeanjean, "Dielectric withstand and breaking capacity of SF<sub>6</sub> circuit breakers at low temperature", IEEE PES Winter Meeting, 1987, paper 87 WM 121-7.
- [2] F. Buret and A. Beroual, "Detecteur optique de phase liquide dans un disjoncteur au SF<sub>6</sub> sous pression", Journal de Physique III, 1, 1991, pp. 667-673.
- [3] A. Beroual and F. Buret, "Optical detector of electrical discharges", IEE Proceedings Part G - Circuits, Devices and Systems, Vol. 138, N°5, October 1991, pp. 620-622.

- [4] Alstom Technical Documentation, FD 0-3-1 F/A AHT.
- [5] L. Nicolas and L. Krähenbühl, "PHI3D: a graphic interactive package for 3D field computations", Conference BETECH 86, Cambridge USA, 1986.
- [6] W. Widl, G. Mauthe, K. Fröhlich and R. Baumgartner, "Comportement des disjoncteurs au SF<sub>6</sub> à des températures extrêmement basses", CIGRE 1988, Rapport 13-14.

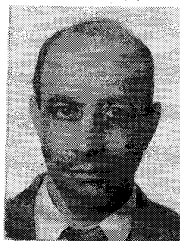

**Abderrahmane Beroual** (M'93) was born in El-Khroub - Constantine, Algeria, on October 30, 1951. He received the M.Sc. and Ph.D degrees in Electrical Engineering, respectively, in 1976 from the "Ecole Nationale Polytechnique" of Algiers and in 1979 from the Technical University of Wroclaw, Poland. In 1987, he obtained the D.Sc. (Dr. d'Etat ès Sciences Physiques) degree from the "Institut National Polytechnique" of Grenoble, France.

In 1980, he joined the Department of Electrical Engineering at the "Ecole Nationale Polytechnique" of Algiers where he supervised graduate and post-graduate students thesis and taught courses in high voltage engineering. He was consultant at Algerian Ministry of High School and Scientific Research. From 1983 to 1987, he was a researcher at the "Laboratoire d'Electrostatique et de Matériaux Diélectriques" (C.N.R.S.) of Grenoble. He also worked as associated assistant Professor in Mathematics and Physics at the Joseph Fourier University of Grenoble.

He joined in september 1987, the "Ecole Nationale Polytechnique" of Algiers where he is full Professor. He was member of many national scientific committees. Presently, he is with the Electrical Engineering Department of the "Ecole Centrale de Lyon", France.

His main research interests are in the area of high voltage and dielectric materials. Author / coauthor of some sixty papers in the field of applied physics and high voltage insulation.



**François Buret** was born in Avignon, France, on August 10, 1955. He is graduate from the "Ecole Normale Supérieure de l'Enseignement Technique" (ENS Cachan) and, in 1986, he obtained his Ph D from the "Institut National Polytechnique de Grenoble", France. His field of interest include specially high voltage insulation. Since 1982, he has been teaching and researching in the Electrical Engineering Department of "Ecole Centrale de Lyon" (URA CNRS 829), France.