

# POWER ELECTRONICS HARMONIC ANALYSIS BASED ON THE LINEAR TIME PERIODIC MODELING. APPLICATIONS FOR AC/DC/AC POWER ELECTRONIC INTERFACE.

*Vanya Ignatova\*, Pierre Granjon\*\*, Seddik Bacha\**

\*LEG: Laboratory of Electrical Engineering of Grenoble, France

\*\*LIS: Laboratory of Images and Signals, France

## SUMMARY

**This paper presents an analytical frequency-domain method for harmonics modeling and evaluation in power electronic systems. The considered system is described by a set of differential equations, which are converted in the frequency domain and presented in a matrix form. Indeed, currents and voltages are described in terms of Fourier series and arranged in a vector form. The passive elements and the switching functions are then represented by harmonic transfer matrices. The resolution of the matrix equations leads to theoretical time and frequency expressions of the system voltages and currents.**

**This method is applied to a closed-loop three phase AC/DC/AC PWM converter. The control loop of the converter is modeled by additional equations. The spectra of the switching functions, necessary to build the corresponding harmonic transfer matrices, are calculated through a double Fourier series decomposition. The matrix equations are solved and the results are compared to those obtained by real measurements and Matlab/Simulink simulations.**

**Key words:** power system harmonics, power electronic, linear time periodic modeling, PWM, control system

## 1. INTRODUCTION

The wide spread use of power electronic devices in power networks is due to their multiple functions: compensation, protection and interface for generators. Adapting and transforming the electric energy, they make possible the insertion in the power network of independent generators and renewable sources of energy. However, because of their switching components, power electronic converters generate current and voltage harmonics which may cause measurements, stability and control problems.

In order to avoid this kind of harmonic disturbances, a good knowledge on the harmonic generation and propagation is necessary. A better understanding of the harmonic transfer mechanisms could make the harmonic attenuation more efficient, optimizing filters and improving power electronic control.

The harmonic study can be effectuated in the time domain or in the frequency domain. In the time domain, currents and voltages spectra are obtained by application of Fourier transform. This domain can not give an analytical harmonic solution for the considered system and the relations between harmonics can not be expressed.

In the frequency domain, several methods for power network harmonic analysis exist [1]. The simplest consists to model the network presenting power electronic devices by known sources of harmonic currents. Another method presents converters by their Norton equivalent.

These two methods are the most often used in the network harmonic analysis. They are simple, but not accurate, because they do not take into account the dynamics of the switching components.

More precise models designed for the power electronic devices exist. Such a model is the transfer function model, which links the converter state variables by matrix equations. Another method proposed in [2] describes the converter by a set of nonlinear equations solved by Newton's method. These models have a good accuracy, but because of their complexity they can not be applied to systems containing multiple converters.

For an accurate network harmonic analysis, a simple and efficient method taking into account the harmonics induced by the switching process is required.

The method proposed in this paper uses the periodicity of the converter variables in steady state in order to put them in a matrix form in the frequency domain. Previous researches in this area have been already made. In [3], the models of power electronic structures are built using harmonic transfer matrices and are implemented in Matlab/Simulink. This method is especially used for stability analysis and for that reason data are simplified and high frequencies are neglected. In [4], a method using the periodicity of the variables is presented, but it only gives a numerical solution and it is not applied in the case of switching circuits and network analysis. Both previous methods do not give analytical expressions of the harmonics.

In this paper the presented method describes the considered system by differential equations, which are then converted in the frequency domain. Being periodic signals, currents and voltages are described in terms of Fourier series and then by vectors of harmonics. The passive elements and the switching

functions are described by matrices. The resolution of the matrix equations gives time and frequency expressions of voltages and currents.

This paper is organized as follows: Section 2 describes the harmonic transfer via the different components of power electronic systems. The method for harmonics assessment is described in Section 3 and illustrated with a simple example. In section 4 the method is applied to a closed-loop three phase PWM AC/DC/AC converter. The obtained results are confirmed by real measurements and simulation in Section 5.

## 2. HARMONIC TRANSFER VIA PASSIVE AND SWITCHING ELEMENTS

Power electronic systems can be considered as combination of switching and passive components. In this section the harmonic propagation through these elements is analysed and the necessity of their matrix representation is demonstrated.

When building the harmonic transfer matrices, some assumptions are made: the switching and the passive components are supposed ideal, the considered system is supposed to be in steady state and periodically time-variant.

### 2.1 Harmonic transfer matrix throughout switching elements

For the simple switching process presented in Fig.1, the relation between ac and dc currents  $i_{ac}(t)$  and  $i_{dc}(t)$  is given by:

$$i_{dc}(t) = u(t)i_{ac}(t), \tag{1}$$

where  $i_{ac}(t)$  is supposed  $T_i$ -periodic (periodic with period of  $T_i$  seconds) and the switching function  $u(t)$  is  $T_u$ -periodic with  $T_i = NT_u$ . In the following,  $N$  is an integer so that  $u(t)$  can be also considered as  $T_i$ -periodic.

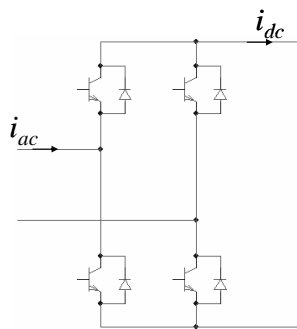

Figure 1: a simple switching process

Therefore, the previous signals can be decomposed in Fourier series as a function of the same fundamental frequency  $\frac{1}{T_i}$  and Eq. (1) finally becomes:

$$i_{dc}(t) = \left( \sum_{n=-\infty}^{\infty} \langle i_{ac} \rangle_n e^{jn\omega_i t} \right) \left( \sum_{m=-\infty}^{\infty} \langle u \rangle_m e^{jm\omega_i t} \right) = \sum_{m=-\infty}^{\infty} \sum_{n=-\infty}^{\infty} \langle i_{ac} \rangle_n \langle u \rangle_m e^{j(n+m)\omega_i t} = \sum_{k=-\infty}^{\infty} \left( \sum_{n=-\infty}^{\infty} \langle i_{ac} \rangle_n \langle u \rangle_{k-n} \right) e^{jk\omega_i t}, \quad (2)$$

where  $\omega_i = \frac{2\pi}{T_i}$ , and  $\langle x \rangle_k = \frac{1}{T_i} \int_{T_i} x(t) e^{-jk\omega_i t} dt$  is the  $k^{\text{th}}$  harmonic component of the  $T_i$ -periodic signal  $x(t)$ .

Eq. (2) shows that  $i_{dc}(t)$  can be viewed as a  $T_i$  periodic signal with the following Fourier coefficients:

$$\langle i_{dc} \rangle_k = \sum_{n=-\infty}^{\infty} \langle u \rangle_{k-n} \langle i_{ac} \rangle_n. \quad (3)$$

By using this relation, Eq. (2) can also be written in a matrix form as follows:

$$\begin{bmatrix} \cdot \\ \cdot \\ \langle i_{dc} \rangle_{k-1} \\ \langle i_{dc} \rangle_k \\ \langle i_{dc} \rangle_{k+1} \\ \cdot \\ \cdot \end{bmatrix} = \begin{bmatrix} \cdot & \cdot & \cdot & \cdot & \cdot & \cdot & \cdot \\ \cdot & \cdot & \cdot & \cdot & \cdot & \cdot & \cdot \\ \cdot & \cdot & \langle u \rangle_0 & \langle u \rangle_{-1} & \langle u \rangle_{-2} & \cdot & \cdot \\ \cdot & \cdot & \langle u \rangle_1 & \langle u \rangle_0 & \langle u \rangle_{-1} & \cdot & \cdot \\ \cdot & \cdot & \langle u \rangle_2 & \langle u \rangle_1 & \langle u \rangle_0 & \cdot & \cdot \\ \cdot & \cdot & \cdot & \cdot & \cdot & \cdot & \cdot \\ \cdot & \cdot & \cdot & \cdot & \cdot & \cdot & \cdot \end{bmatrix} \begin{bmatrix} \cdot \\ \cdot \\ \langle i_{ac} \rangle_{k-1} \\ \langle i_{ac} \rangle_k \\ \langle i_{ac} \rangle_{k+1} \\ \cdot \\ \cdot \end{bmatrix}, \quad (4)$$

or with a shorter notation:

$$[I_{dc}] = [U][I_{ac}]. \quad (5)$$

The matrix  $[U]$  is called the ‘‘harmonic transfer matrix’’ of the considered switching elements. It only depends on the Fourier coefficients of the switching function  $u(t)$ , and follows a Toeplitz structure, which means that its elements situated on the same diagonal are equal.

## 2.2 Harmonic transfer matrix for passive elements

For passive elements, for example a capacitor, the relation between current and voltage harmonics is given by the formulae:

$$i = C \frac{dv}{dt} \Rightarrow \langle i \rangle_k = C \left\langle \frac{dv}{dt} \right\rangle_k = C \frac{d \langle v \rangle_k}{dt} + jk\omega C \langle v \rangle_k. \quad (6)$$

As the system is considered in its steady state, the harmonics do not vary with time, which implies the following simplification:

$$\langle v \rangle_k = \text{const} \Rightarrow \frac{d \langle v \rangle_k}{dt} = 0 \Rightarrow \langle i \rangle_k = jk\omega C \langle v \rangle_k, \quad (7)$$

and the relation between the voltage and current harmonics can be expressed in the following matrix form:

$$\begin{bmatrix} \cdot \\ \cdot \\ \langle i \rangle_{k-1} \\ \langle i \rangle_k \\ \langle i \rangle_{k+1} \\ \cdot \\ \cdot \end{bmatrix} = \begin{bmatrix} \cdot & 0 & 0 & 0 & 0 & 0 & 0 \\ 0 & \cdot & 0 & 0 & 0 & 0 & 0 \\ 0 & 0 & j(k-1)\omega C & 0 & 0 & 0 & 0 \\ 0 & 0 & 0 & jk\omega C & 0 & 0 & 0 \\ 0 & 0 & 0 & 0 & j(k+1)\omega C & 0 & 0 \\ 0 & 0 & 0 & 0 & 0 & \cdot & 0 \\ 0 & 0 & 0 & 0 & 0 & 0 & \cdot \end{bmatrix} \begin{bmatrix} \cdot \\ \cdot \\ \langle v \rangle_{k-1} \\ \langle v \rangle_k \\ \langle v \rangle_{k+1} \\ \cdot \\ \cdot \end{bmatrix} \quad (8)$$

Analogically, harmonic transfer matrices through an inductor and a resistor can be expressed by matrix Eq. (9) and (10) respectively.

$$\begin{bmatrix} \cdot \\ \cdot \\ \langle v \rangle_{k-1} \\ \langle v \rangle_k \\ \langle v \rangle_{k+1} \\ \cdot \\ \cdot \end{bmatrix} = \begin{bmatrix} \cdot & 0 & 0 & 0 & 0 & 0 & 0 \\ 0 & \cdot & 0 & 0 & 0 & 0 & 0 \\ 0 & 0 & j(k-1)\omega L & 0 & 0 & 0 & 0 \\ 0 & 0 & 0 & jk\omega L & 0 & 0 & 0 \\ 0 & 0 & 0 & 0 & j(k+1)\omega L & 0 & 0 \\ 0 & 0 & 0 & 0 & 0 & \cdot & 0 \\ 0 & 0 & 0 & 0 & 0 & 0 & \cdot \end{bmatrix} \begin{bmatrix} \cdot \\ \cdot \\ \langle i \rangle_{k-1} \\ \langle i \rangle_k \\ \langle i \rangle_{k+1} \\ \cdot \\ \cdot \end{bmatrix} \quad (9)$$

$$\begin{bmatrix} \cdot \\ \cdot \\ \langle v \rangle_{k-1} \\ \langle v \rangle_k \\ \langle v \rangle_{k+1} \\ \cdot \\ \cdot \end{bmatrix} = \begin{bmatrix} \cdot & 0 & 0 & 0 & 0 & 0 & 0 \\ 0 & \cdot & 0 & 0 & 0 & 0 & 0 \\ 0 & 0 & R & 0 & 0 & 0 & 0 \\ 0 & 0 & 0 & R & 0 & 0 & 0 \\ 0 & 0 & 0 & 0 & R & 0 & 0 \\ 0 & 0 & 0 & 0 & 0 & \cdot & 0 \\ 0 & 0 & 0 & 0 & 0 & 0 & \cdot \end{bmatrix} \begin{bmatrix} \cdot \\ \cdot \\ \langle i \rangle_{k-1} \\ \langle i \rangle_k \\ \langle i \rangle_{k+1} \\ \cdot \\ \cdot \end{bmatrix} \quad (10)$$

This shows that transfer matrices of passive elements have a diagonal structure.

The matrix form used here to represent the transfer function of passive components has to be used in order to describe the whole considered system because of the presence of switching components.

### 3. METHOD FOR HARMONICS EVALUATION

In this section, the method for harmonics evaluation is presented in details and applied to a simple converter structure in order to illustrate its properties.

#### 3.1 Algorithm

The method is composed of the following steps [5,6]:

- The considered converter structure is described by differential equations. The equations number depends on the number of inductances and capacitors in the system.

- The differential equations are converted in the frequency domain and represented in a matrix form. Currents and voltages are represented by vectors of harmonics, passive elements become matrices with diagonal structure, and the switching functions become matrices with Toeplitz structure.
- The matrix equations are solved in the frequency domain, and the frequency expression of the currents and voltages is obtained. Their time expression can also be deduced by Fourier series.

### 3.2 Example

In order to be better illustrated, the previous method is applied to the simple converter structure described in Fig. 2 and containing both passive and switching elements.

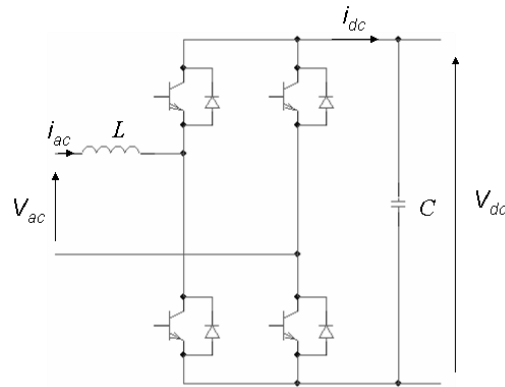

Figure 2: a simple converter structure

The matrix equations describing the considered system are:

$$\begin{cases} [I_{dc}] = [C][V_{dc}] \\ [I_{ac}] = [U][I_{dc}] \\ [L][I_{ac}] = [V_{ac}] - [U][V_{dc}] \end{cases}, \text{ where} \quad (11)$$

$[C]$  and  $[L]$  are the capacitor and the inductor diagonal matrices,

$[U]$  is the switching function matrix with a Toeplitz structure,

$[V_{dc}]$ ,  $[V_{ac}]$ ,  $[I_{dc}]$  et  $[I_{ac}]$  are vectors containing the harmonics of the corresponding state variables.

A problem which may occur in this case is the non inversibility of the matrices corresponding to the inductor and the capacitor when the dc component (harmonic of rang 0) is taken into account. Fortunately, the inversion of these matrices can be avoided by simple mathematical permutations. The solution of the matrix equations avoiding the inversion of the capacitor and inductor matrices is in this case:

$$\begin{cases} [V_{dc}] = ([L][U][C] + [U])^{-1}[V_{ac}] \\ [I_{ac}] = [U][C][V_{dc}] \\ [I_{dc}] = [C][V_{dc}] \end{cases} \quad (12)$$

It can be noted that this method directly leads to an analytical solution of the harmonics of the different electrical quantities. For this reason, this frequency domain method can be considered as more accurate and rapid than the time domain one, where time waveforms of the state variables are first obtained, and then corresponding spectra are deduced. Another advantage of this method is that the harmonics analytical expression can be used to increase the efficiency in harmonics reduction and elimination.

#### 4. APPLICATION OF THE METHOD TO AN AC/DC/AC CONVERTER

In order to completely illustrate the previous method, the model of a closed-loop AC/DC/AC PWM converter is elaborated. The considered structure is chosen because of its complexity and its wide spread use as power interface. The considered system is composed of two converters having the same structure (see Fig. 3), so that the application of the method is presented only for the AC/DC converter. The method can be analogically applied to the whole converter structure by using similar equations for the second converter.

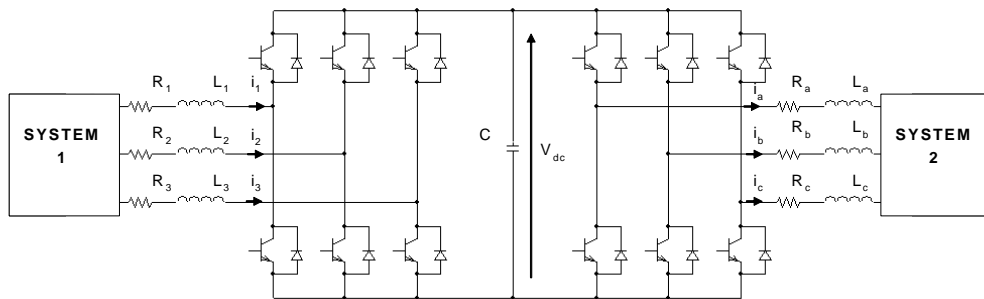

Figure 3: AC/DC/AC three phase converter used as power interface

##### 4.1 Modeling the AC/DC PWM converter

The method is first applied to the AC/DC converter described in Fig.4, where the DC/AC converter of Fig.3 has been replaced by a resistor.

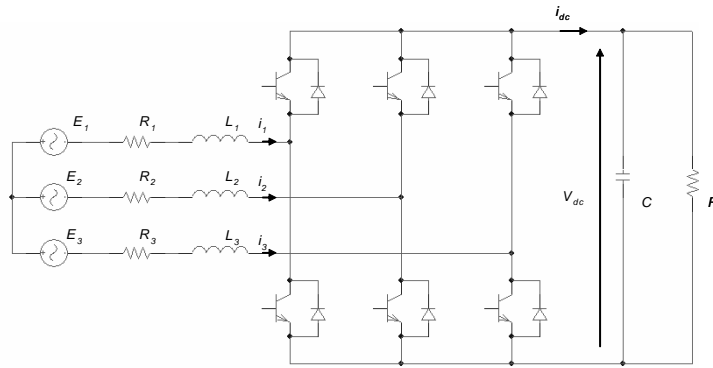

Figure 4: AC/DC converter

By supposing switching components, passive elements, and network voltage as ideal, the converter can be described by the set of following differential equations:

$$\begin{cases} L_1 \frac{di_1(t)}{dt} = V_1(t) - R_1 i_1(t) - (2u_1(t) - u_2(t) - u_3(t)) \frac{V_{dc}(t)}{6} \\ L_2 \frac{di_2(t)}{dt} = V_2(t) - R_2 i_2(t) - (2u_2(t) - u_1(t) - u_3(t)) \frac{V_{dc}(t)}{6} \\ L_3 \frac{di_3(t)}{dt} = V_3(t) - R_3 i_3(t) - (2u_3(t) - u_1(t) - u_2(t)) \frac{V_{dc}(t)}{6} \\ C \frac{dV_{dc}(t)}{dt} = \frac{1}{2} (u_1(t)i_1(t) + u_2(t)i_2(t) + u_3(t)i_3(t)) - \frac{V_{dc}(t)}{R} \end{cases}, \quad (13)$$

where  $u_i(t)$  is the switching function of the  $i^{th}$  converter leg:

$$u_i(t) = \begin{cases} 1 \\ -1 \end{cases}. \quad (14)$$

In steady state, these equations can be converted in the frequency-domain and presented in the following matrix form:

$$\begin{cases} [L_1][I_1] = [V_1] - [R_1][I_1] - \frac{1}{6} (2[U_1] - [U_2] - [U_3])[V_{dc}] \\ [L_2][I_2] = [V_2] - [R_2][I_2] - \frac{1}{6} (2[U_2] - [U_1] - [U_3])[V_{dc}] \\ [L_3][I_3] = [V_3] - [R_3][I_3] - \frac{1}{6} (2[U_3] - [U_1] - [U_2])[V_{dc}] \\ [C][V_{dc}] = \frac{1}{2} ([U_1][I_1] + [U_2][I_2] + [U_3][I_3]) - [R]^{-1}[V_{dc}] \end{cases}. \quad (15)$$

The state variables are represented by a set of vectors of harmonics, and the system parameters by matrices as described in the previous section:

$$[I_k] = [ \dots \langle I_k \rangle_{-2} \quad \langle I_k \rangle_{-1} \quad \langle I_k \rangle_0 \quad \langle I_k \rangle_1 \quad \langle I_k \rangle_2 \quad \dots ]^T \quad k = 1, 2, 3$$

$$[V_{dc}] = [ \dots \langle V_{dc} \rangle_{-2} \quad \langle V_{dc} \rangle_{-1} \quad \langle V_{dc} \rangle_0 \quad \langle V_{dc} \rangle_1 \quad \langle V_{dc} \rangle_2 \quad \dots ]^T$$

$$\begin{aligned}
[L_k] &= \text{diag} (j\omega HL_k) \quad k = 1,2,3 \\
[R_k] &= \text{diag} (j\omega HR_k) \quad k = 1,2,3, \\
[C] &= \text{diag} (j\omega HC) \\
[R] &= \text{diag} (R)
\end{aligned} \tag{16}$$

where  $[H]$  is a vector containing the ranks of the harmonics:

$$[H] = [ \dots -2 \quad -1 \quad 0 \quad 1 \quad 2 \quad \dots ]. \tag{17}$$

Matrices  $[U_1]$ ,  $[U_2]$  and  $[U_3]$  contain the Fourier coefficients of the different switching functions:

$$\begin{aligned}
[U_1] &= \text{toeplitz} [ \dots \langle u_1 \rangle_{-2} \quad \langle u_1 \rangle_{-1} \quad \langle u_1 \rangle_0 \quad \langle u_1 \rangle_1 \quad \langle u_1 \rangle_2 \quad \dots ] \\
[U_2] &= \text{toeplitz} [ \dots \langle u_2 \rangle_{-2} \quad \langle u_2 \rangle_{-1} \quad \langle u_2 \rangle_0 \quad \langle u_2 \rangle_1 \quad \langle u_2 \rangle_2 \quad \dots ] \\
[U_3] &= \text{toeplitz} [ \dots \langle u_3 \rangle_{-2} \quad \langle u_3 \rangle_{-1} \quad \langle u_3 \rangle_0 \quad \langle u_3 \rangle_1 \quad \langle u_3 \rangle_2 \quad \dots ]
\end{aligned} \tag{18}$$

These Fourier coefficients are obtained by using Fourier series decomposition in the case of periodic switching function (for example full-wave converters). In the case of PWM converters, the switching function is not exactly periodic, but it can be represented as a two-dimensional function of the career and the reference waveforms, which are periodic. Therefore, the Fourier coefficients can be obtained through a double Fourier series decomposition. For example, the switching function of a naturally sampled PWM is given by [7]:

$$u_i(t) = M \cos(\omega t + \theta + (i-1)\frac{2\pi}{3}) + \frac{4}{\pi} \sum_{m=1}^{\infty} \sum_{n=-\infty}^{\infty} \frac{1}{m} \left\{ \sin\left([m+n]\frac{\pi}{2}\right) J_n\left(m\frac{\pi}{2}M\right) \cos\left(m[\omega_c t + \theta_c] + n\left[\omega t + \theta(i-1)\frac{2\pi}{3}\right]\right) \right\}, \tag{19}$$

where

$M$  is the magnitude of the modulating signal,

$\omega_c$  and  $\theta_c$  are the carrier pulsation and phase,

$\omega$  and  $\theta$  are the fundamental pulsation and phase,

$J_n(\ )$  is the Bessel function of order  $n$ .

By supposing that the career frequency  $\omega_c$  is an integer multiple of the fundamental frequency  $\omega$ , the Fourier coefficients of  $u_i(t)$  can be easily determined from Eq. (19).

## 4.2 Control modeling

In open loop, the magnitude  $M$  and phase  $\theta$  of the modulating signal used for the calculation of the Fourier coefficients of the switching function are known and constant. In closed loop these two parameters are used to control the magnitudes of the converter state variables, usually the ac current. For that reason they are not fixed, but depend on the real and the desired (reference) values of the controlled state variables.

In this section the impact of the control system is taken into account by calculating the phase and magnitude of the modulating signal. In the proposed algorithm, the converter Eq. (13) are first solved for the fundamental frequency, and the fundamental of the switching function is found by replacing the converter state variables by their reference values. The modulating signal parameters are found using the fact that the modulating signal is the fundamental of the switching function. By knowing  $M$  and  $\theta$  the real switching function can be calculated and the method for harmonics estimation presented in Section 3 can be applied. The described algorithm is given in details in this section.

The converter state variables and switching functions are supposed symmetrical, only the fundamental component is taken into account:

$$\begin{cases} i_1 = i \\ i_2 = ie^{-j\frac{2\pi}{3}} \\ i_3 = ie^{j\frac{2\pi}{3}} \end{cases} \quad \begin{cases} V_1 = V \\ V_2 = Ve^{-j\frac{2\pi}{3}} \\ V_3 = Ve^{j\frac{2\pi}{3}} \end{cases} \quad \begin{cases} u_1 = u \\ u_2 = ue^{-j\frac{2\pi}{3}} \\ u_3 = ue^{j\frac{2\pi}{3}} \end{cases} \quad (20)$$

The passive elements in the three phase are considered as equal:

$$\begin{cases} L_1 = L_2 = L_3 = L_k \\ R_1 = R_2 = R_3 = R_k \end{cases} \quad (21)$$

By using (20) and (21), only one phase of the converter can be considered. Then, Eq. (13) become:

$$\begin{cases} L_k \frac{di}{dt} = V - u \frac{V_{dc}}{6} - R_k i \\ C \frac{dV_{dc}}{dt} = \frac{3}{2} ui - \frac{V_{dc}}{R} \end{cases} \quad (22)$$

The converter variables and switching function are transformed in the dq0 frame in order to make them appear as constant:

$$\begin{cases} i = i_d + ji_q \\ V = V_d + jV_q \\ u = u_d + ju_q \end{cases} \quad (23)$$

Equations (22) transformed in the dq0 frame become:

$$\begin{cases} L \frac{di_d}{dt} = \omega L_k i_q - R_k i_d + V - \frac{1}{2} u_d V_{dc} \\ L_k \frac{di_q}{dt} = -\omega L_k i_d - R_k i_q - \frac{1}{2} u_q V_{dc} \\ C \frac{dV_{dc}}{dt} = \frac{3}{2} (u_d i_d + u_q i_q) - \frac{V_{dc}}{R} \end{cases} \quad (24)$$

The magnitudes of the state variables are constant in the dq0 frame, so that their derivatives are equal to zero:

$$\frac{di_d}{dt} = 0 \quad \frac{di_q}{dt} = 0 \quad \frac{dV_{dc}}{dt} = 0 \quad (25)$$

By supposing the ac current equal to its reference value (the PI controllers are ideal), the  $d$  and  $q$  components of the switching functions can be found.

$$\begin{cases} V_{dc} = \sqrt{\frac{3}{2} R (i_{dref} (\omega L_k i_{qref} - R_k i_{dref} - V) + i_{qref} (-\omega L_k i_{dref} - R_k i_{qref}))} \\ u_d = \frac{2}{V_{dc}} (\omega L_k i_{qref} - R_k i_{dref} - V) \\ u_q = \frac{2}{V_{dc}} (-\omega L_k i_{dref} - R_k i_{qref}) \end{cases} \quad (26)$$

From the obtained values of  $u_d$  and  $u_q$ , the fundamental magnitude and phase of the switching function are then calculated:

$$\begin{cases} M = \sqrt{u_d^2 + u_q^2} \\ \theta_0 = -\arctan\left(\frac{u_q}{u_d}\right) \end{cases} \quad (27)$$

### 4.3 Application of the method to the whole converter structure

The resistor of Fig.4 is replaced by DC/AC converter. Similar equations are used to describe the whole system. The converter structure is connected to the grid and a resistor is used as load. The PWM frequency is 2kHz. The obtained results are compared with those obtained by measurements and simulation, and are presented in the following section.

## 5. SIMULATION AND PRACTICAL RESULTS

The results obtained from the theoretical method, the Matlab/Simulink simulation, and the experimental bench are compared in this section.

### 5.1 Theoretical method

The matrix equations describing the converter and its control system are implemented. The switching functions and the known state variables as the input voltage are decomposed in Fourier series and the corresponding harmonic transfer matrices and vectors are built. The resolution of the matrix system equations leads to the frequency expression of the converter state variables, and the corresponding

time waveforms can be eventually determined by inverse Fourier transform. The calculation time depends on the number of harmonics considered in the different signals.

### 5.2 Matlab/Simulink simulation

A model of the converter based on its differential equations is implemented under Matlab/Simulink. The obtained results are in the time domain and a Fourier transformation is used to obtain the currents and voltages spectra.

### 5.3 Experimental bench

The experimental bench is presented in Fig. 5 and its structure in Fig. 6. The network voltage is adapted through autotransformers.

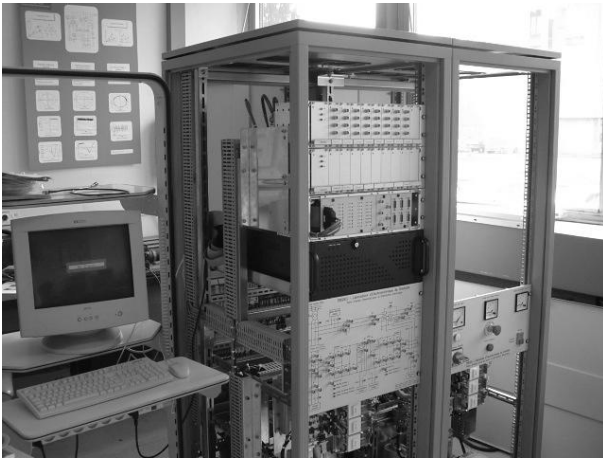

Figure 5: Experimental bench

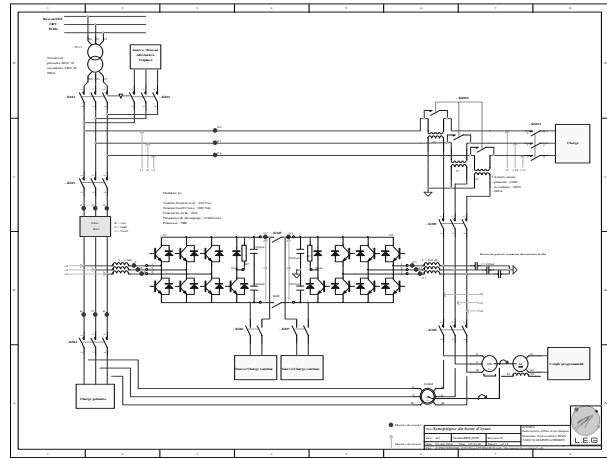

Figure 6: Experimental bench description

### 5.4 Results

Theoretical results are compared to those obtained by measurements and Matlab/Simulink simulations. In Fig. 7, the spectrum of the ac current from the network side is shown between 1500 and 6500 Hz (around PWM harmonics). In the three cases, the harmonics are situated at the same frequencies and have almost the same magnitudes. The small differences are due to the assumptions used in our method, the simulation errors, and the disturbances in the real system (non-ideal components, noises, etc.). The results obtained for the dc voltage and the ac current from the load side are quite similar.

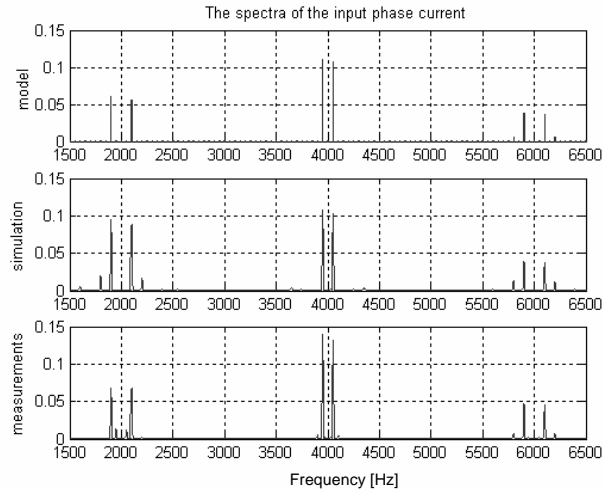

Figure 7: AC current spectrum from the network side; theoretical, simulation, and experimental results

## 6. CONCLUSION

A new analytical frequency-domain method for harmonics modeling and evaluation in power electronic systems has been presented in this paper. The considered system is described by a set of differential equations, which are converted in the frequency domain and presented in a matrix form. The resolution of these matrix equations leads to theoretical expressions of the different voltages and currents. It can be noted that this method is designed for power systems with periodically switching components, and leads to an analytical expression of the different electrical quantities, which is one of its main advantages. Indeed, this allows to determine the influence of the system parameters (control strategy, passive elements, *etc.*) on the harmonic contents of the converter state variables. It can be successfully applied for power quality assesment, harmonic filters optimisation and converter control design.

## 7. LIST OF SYMBOLS

$i_{ac}, I_{ac}$	Alternative current
$i_{dc}, I_{dc}$	Direct current
$L$	Inductance
$M$	Magnitude of the modulating signal
$R$	Resistor
$C$	Capacitor
$u, U$	Switching function of one leg
$v$	Voltage

$V_{ac}$	Alternative voltage
$V_{dc}$	Direct voltage
$\omega$	Fundamental pulsation
$\omega_c$	Carrier pulsation
$\theta$	Fundamental phase
$\theta_c$	Carrier phase

## 8. REFERENCES

- [1] Task Force on Harmonics Modeling and Simulation, IEEE PES Harmonic Working Group: “Characteristics and modeling of harmonic sources- power electronic devices”, IEEE Transactions on Power Delivery. vol.16, no.4, Oct. 2001; p.791-800
- [2] Bathurst-G, Smith-B, Watson-N, Arrillaga-J: “Modelling of HVDC transmission systems in the Harmonic Domain”, IEEE Transactions on Power Delivery, Vol.14, No.3, July 1999
- [3] Mollerstedt-E., Bernhardsson-B.: “A harmonic transfer function model for a diode converter train”, 2000-IEEE-Power-Engineering-Society-Winter-Meeting.-Conference-Proceedings-Cat.-No.00CH37077. 2000: 957-62 vol.2
- [4] Vanassche-P., Gielen-G., Sansen-W.: “Symbolic modeling of periodically time- varying systems using harmonic transfer matrices” IEEE Transactions on computer-aided design of integrated circuits and systems, Vol.21, No.9, September 2002
- [5] Ignatova-V, Bacha-S, Granjon-P, Retière-N: “Linear time periodic modeling of power electronic devices for power system harmonic analysis and simulation” SAAEI-EPF 2004
- [6] Ignatova-V, Bacha-S, Granjon-P: “An analytical method for power quality assessment applied to grid connected power electronic converters” CIRED 2005
- [7] Holmes-D., McGrath-P.: “Opportunities for harmonic cancellation with carrier-based PWM for two-level and multilevel cascaded inverters” IEEE Transactions on industry applications, Vol.37, No.2, March/Avril 2001

## 9. BIOGRAPHIES



**Vanya Ignatova** (vanya.ignatova@leg.ensieg.inpg.fr) was born in Sofia, Bulgaria in 1979. She received her master degree in Electrical Engineering from the Technical University in Sofia in 2002. Currently, she is a Ph.D. student in the Laboratory of Electrical Engineering of Grenoble, France. Her main research interests include power quality, voltage sags and power system harmonics.

**Pierre Granjon** (pierre.granjon@lis.inpg.fr) was born in France in 1971. He received the M.S. in electrical engineering from the University Center of Science and Technology, Clermont-Ferrand, France, in 1994 and the Ph.D. degree from the National Polytechnic Institute of Grenoble (INPG), France in 2000. He joined the Laboratory of Images and Signals (LIS) at INPG in 2001, where he holds a position as assistant professor. His general interests cover signal processing theory such as nonlinear signals and filters (higher order statistics, Volterra filters), non stationary signals and filters (cyclostationarity, LPTV filters) and active control. His current research is mainly focused on signal processing applications in electrical engineering such as fault diagnosis in electrical machines and power networks.

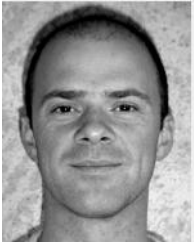

**Seddik Bacha** (seddik.bacha@leg.ensieg.inpg.fr) received his Engineer and Master from National Polytechnic Institute of Algiers respectively in 1982 and 1990. He joined the Laboratory of Electrical Engineering of Grenoble (LEG) and received his PhD and HDR respectively in 1993 and 1998. He is presently manager of Power System Group of LEG and Professor at the University Joseph Fourier of Grenoble. His main fields of interest are power electronic systems, modeling and control, power quality, renewable energy integration.

