

QUANTITATIVE LOWER BOUNDS FOR THE FULL BOLTZMANN EQUATION, PART I: PERIODIC BOUNDARY CONDITIONS

CLÉMENT MOUHOT

ABSTRACT. We prove the appearance of an explicit lower bound on the solution to the full Boltzmann equation in the torus for a broad family of collision kernels including in particular long-range interaction models, under the assumption of some uniform bounds on some hydrodynamic quantities. This lower bound is independent of time and space. When the collision kernel satisfies Grad's cutoff assumption, the lower bound is a global Maxwellian and its asymptotic behavior in velocity is optimal, whereas for non-cutoff collision kernels the lower bound we obtain decreases exponentially but faster than the Maxwellian. Our results cover solutions constructed in a spatially homogeneous setting, as well as small-time or close-to-equilibrium solutions to the full Boltzmann equation in the torus. The constants are explicit and depend on the *a priori* bounds on the solution.

CONTENTS

1. Introduction	1
2. Functional toolbox	9
3. Proof of the lower bound in the cutoff case	18
4. Proof of the lower bound in the non-cutoff case	23
5. Application to the existing Cauchy theories	31
References	35

1. INTRODUCTION

This paper is devoted to the study of qualitative properties of the solutions to the full Boltzmann equation in the torus for a broad family of collision kernels. In this work we shall quantify the positivity of the solution by proving the “immediate” appearance of a stationary lower bound, uniform in space. Before we explain our results and methods in more details let us introduce the problem in a precise way.

1.1. Motivation. The Boltzmann equation describes the behavior of a dilute gas; when we assume periodic boundary conditions in space, it reads

$$\frac{\partial f}{\partial t} + v \cdot \nabla_x f = Q(f, f), \quad x \in \mathbb{T}^N, \quad v \in \mathbb{R}^N, \quad t \in [0, T),$$

where $T \in (0, +\infty]$, \mathbb{T}^N is the N -dimensional torus, the unknown $f = f(t, x, v)$ is a time-dependent probability density on $\mathbb{T}_x^N \times \mathbb{R}_v^N$ ($N \geq 2$), and Q is the quadratic Boltzmann collision operator. It is local in t and x and we define it by the bilinear form

$$Q(g, f) = \int_{\mathbb{R}^N} dv_* \int_{\mathbb{S}^{N-1}} d\sigma B(|v - v_*|, \cos \theta) (g'_* f' - g_* f).$$

Here we have used the shorthands $f' = f(v')$, $g_* = g(v_*)$ and $g'_* = g(v'_*)$, where

$$v' = \frac{v + v_*}{2} + \frac{|v - v_*|}{2} \sigma, \quad v'_* = \frac{v + v_*}{2} - \frac{|v - v_*|}{2} \sigma$$

stand for the pre-collisional velocities of particles which after collision have velocities v and v_* . Moreover $\theta \in [0, \pi]$ is the deviation angle between $v' - v'_*$ and $v - v_*$, and B is the Boltzmann collision kernel (related to the cross-section $\Sigma(v - v_*, \sigma)$ by the formula $B = \Sigma|v - v_*|$), determined by physics. On physical grounds, it is assumed that $B \geq 0$ and that B is a function of $|v - v_*|$ and $\cos \theta = \left\langle \frac{v - v_*}{|v - v_*|}, \sigma \right\rangle$.

In this paper we shall be concerned with the case when B takes the following product form

$$(1.1) \quad B(v - v_*, \sigma) = \Phi(|v - v_*|) b(\cos \theta)$$

where Φ satisfies either the assumption

$$(1.2) \quad \forall z \in \mathbb{R}, \quad c_\Phi |z|^\gamma \leq \Phi(z) \leq C_\Phi |z|^\gamma$$

or the mollified assumption

$$(1.3) \quad \begin{cases} \forall |z| \geq 1, & c_\Phi |z|^\gamma \leq \Phi(z) \leq C_\Phi |z|^\gamma \\ \forall |z| \leq 1, & c_\Phi \leq \Phi(z) \leq C_\Phi \end{cases}$$

with $c_\Phi, C_\Phi > 0$ and $\gamma \in (-N, 1]$, and b is a continuous function on $\theta \in (0, \pi]$, strictly positive on $\theta \in (0, \pi)$, such that

$$(1.4) \quad b(\cos \theta) \sin^{N-2} \theta \sim_{\theta \rightarrow 0^+} b_0 \theta^{-1-\nu}$$

for some $b_0 > 0$ and $\nu \in (-\infty, 2)$. The assumption (1.1) that B takes a tensorial form is made for the sake of convenience, since it is a well-accepted hypothesis which covers important physical cases. Most probably it could be relaxed to non-tensorial collision kernels with the same kind of controls, up to some technical refinements. The assumption that b is strictly positive on $\theta \in (0, \pi)$ is a technical requirement for Lemma 2.3 and Lemma 2.4 in Section 2 and it could be relaxed to the requirement that b is strictly positive near $\theta \sim \pi/2$.

Following the usual taxonomy we shall denote by “hard potential” collision kernels the case when $\gamma > 0$, “Maxwellian” collision kernels the case when $\gamma = 0$, and “soft potential” collision kernels the case when $\gamma < 0$. When Φ satisfies assumption (1.3) and not (1.2) we shall speak of “mollified soft potentials” collision kernels or “mollified hard potentials” collision kernels. In the case when $\nu < 0$, the angular collision kernel is locally integrable, an assumption which is usually referred to as *Grad’s cutoff assumption* (see [20]). Thus

for $\nu < 0$ we shall speak of “cutoff” collision kernels, and for $\nu \geq 0$ we shall speak of “non-cutoff” collision kernels.

The main cases of application are “hard spheres” interaction (b constant and $\Phi(z) = |z|$ which corresponds to the case $\gamma = 1$ and $\nu = -1$), and interactions deriving from a $1/r^s$ force ($s > 2$), where r is the distance between particles, which corresponds to $\gamma = (s - 5)/(s - 1)$ and $\nu = 2/(s - 1)$ in dimension 3.

In the case when the solution $f(t, v)$ does not depend on the space variable x , we shall speak of spatially homogeneous solution.

The attempts to quantify the strict positivity of the solution to the Boltzmann equation are as old as the mathematical theory of the Boltzmann equation, since Carleman himself established such estimates in his pioneering paper [6]. He showed, for hard potentials with cutoff in dimension 3, that the spatially homogeneous solutions radially symmetric in v he had constructed in $L_6^\infty(\mathbb{R}_v^N)$ ¹ (the very first result in the Cauchy theory) satisfy a lower bound of the form

$$\forall t \geq t_0 > 0, \forall v \in \mathbb{R}^3 \quad f(t, v) \geq C_1 e^{-C_2 |v|^{2+\varepsilon}},$$

for any fixed $t_0 > 0$ and $\varepsilon > 0$. The constants $C_1, C_2 > 0$ are uniform as $t \rightarrow +\infty$ and depend on t_0, ε and some estimates on the solution. The proof was based on a “spreading property” of the collision operator and the assumption that the initial datum is uniformly bounded from below by a positive quantity on a ball centered at the origin (in fact the weaker assumption of a lower bound on an annulus is sufficient, see [6]).

This result remained unchallenged until the paper from Pulvirenti and Wennberg [30]. They proved, for hard potentials with cutoff in dimension 3, that the spatially homogeneous solutions in $L_2^1(\mathbb{R}_v^N)^2$ with bounded entropy (see [3] and [28]) satisfy a lower bound of the form

$$\forall t \geq t_0 > 0, \forall v \in \mathbb{R}^3 \quad f(t, v) \geq C_1 e^{-C_2 |v|^2},$$

for any fixed $t_0 > 0$. Again $C_1, C_2 > 0$ are uniform as $t \rightarrow +\infty$ and depend on t_0 and some estimates on the solution. Their proof was also based on the spreading property of the collision operator but the optimal decay of the lower bound was obtained by some improvements of the computations. Moreover they made a clever use of the iterated gain part of the collision kernel in order to establish the immediate appearance of a positive minoration of the solution on a ball, thus getting rid of the assumption of Carleman on the initial datum. This paper is the starting point of our study.

Two other methods should be mentioned.

On one hand, Fournier [15, 17] established by delicate probabilistic techniques that the spatially homogeneous solutions to the Kac equation without cutoff satisfy $f(t, v) \in C^\infty((0, +\infty) \times \mathbb{R}^N)$ and

$$\forall t > 0, \forall v \in \mathbb{R}^N, \quad f(t, v) > 0.$$

He proved the same kind of result in [16] for the spatially homogeneous Boltzmann equation without cutoff in dimension 2 under technical restrictions.

¹see Subsection 1.4 for the notations

²id.

On the other hand there is a work in progress by Villani in order to establish lower bounds on the solution to the Boltzmann equation using suitable maximum principles. The most important feature of this new method is that it applies to the non-cutoff case. For more explanations we refer to [36, Chapter 2, Section 6]. This method has been able to recover more simply the results by Fournier, and a quantitative lower bound is in progress. We also refer to the work [18] which proves with the same tools the propagation of upper Maxwellian bounds for the spatially homogeneous solutions to the Boltzmann equation for hard spheres.

Finally we note that in the case of the spatially homogeneous Landau equation with Maxwellian or hard potentials interactions, one can prove a theorem similar to that of Pulvirenti and Wennberg by means of the standard maximum principle for parabolic equations, see [9]. Actually the result stated in this paper is not uniform as $t \rightarrow +\infty$, but it can be made uniform by the same argument as in the proof of Theorem 1.1 in Section 3 below.

The study of lower bounds is of interest in itself, in order to understand the qualitative behaviour of solutions to the Boltzmann equation. Moreover recently this interest has been renewed by the emergence of a new quantitative method in the study of convergence to equilibrium, the so-called “entropy-entropy production” method (see [31, 32, 10, 37]). This method requires indeed a control from below on the solution by a function decreasing at most exponentially, and uniform in time. It has been applied lately to some inhomogeneous kinetic equations: see [11] for the Fokker-Planck equation and [12] for the full Boltzmann equation. For instance the main result in [12] asserts that any solution of the Boltzmann equation satisfying uniform estimates of smoothness and fast decay at large velocities, combined with a lower bound like

$$(1.5) \quad \forall t \geq t_0 > 0, \forall x \in \mathbb{T}^N, \forall v \in \mathbb{R}^N, \quad f(t, x, v) \geq C_1 e^{-C_2 |v|^K}$$

for some $C_1, C_2, K > 0$, does converge to equilibrium at rate “almost exponential”, i.e. faster than any inverse power of t . This paper works in some *a priori* setting on the solution, since there is no general Cauchy theory whose solutions satisfies suitable estimates to apply the “entropy-entropy production” method. Nevertheless a natural question is whether the set of solution satisfying the *a priori* assumptions of [12] is not trivial, i.e. reduced to the spatially homogeneous case or to cases for which exponential convergence results are already known. Our study answers to this question, since the solutions in [21] satisfy all the estimates of regularity and decay needed in [12], and a consequence of Theorem 1.1 below is that they also satisfy (1.5) (with $K = 2$).

1.2. Statement of the results. Now let us introduce the functional spaces and the macroscopic quantities on the solution. We define bounds uniform in space on the observables of the solutions. We shall study precisely in Section 5 in which case there is a Cauchy theory which fits these assumptions. One can say briefly that they are satisfied at least for hard spheres and inverse power laws interactions, either in the spatially homogeneous setting, or in the spatially inhomogeneous setting for solutions “in the small” (i.e. for small time or near the equilibrium).

Let us consider a function $f(t, x, v) \geq 0$ on $[0, T) \times \mathbb{T}^N \times \mathbb{R}^N$. We define its *local density*

$$\rho_f(t, x) := \int_{\mathbb{R}^N} f(t, x, v) dv,$$

its *local energy*

$$e_f(t, x) := \int_{\mathbb{R}^N} f(t, x, v) |v|^2 dv,$$

a weighted local energy

$$e'_f(t, x) := \int_{\mathbb{R}^N} f(t, x, v) |v|^{\tilde{\gamma}} dv$$

(where $\tilde{\gamma}$ is the positive part of $(2 + \gamma)$), its *local entropy*

$$h_f(t, x) := - \int_{\mathbb{R}^N} f(t, x, v) \log f(t, x, v) dv,$$

its local L^p norm ($p \in [1, +\infty)$)

$$l_f^p(t, x) := \|f(t, x, \cdot)\|_{L^p(\mathbb{R}^N)},$$

and its local $W^{2, \infty}$ norm ³

$$w_f(t, x) := \|f(t, x, \cdot)\|_{W^{2, \infty}(\mathbb{R}^N)}.$$

Note that in the sequel we shall systematically speak of hydrodynamical quantities on the solution in a generalized sense, since we include in this term the quantities e'_f , h_f , l_f^p and w_f .

Then we define the following uniform bounds

$$\begin{aligned} \varrho_f &:= \inf_{(t, x) \in [0, T) \times \mathbb{T}^N} \rho_f(t, x), & E_f &:= \sup_{(t, x) \in [0, T) \times \mathbb{T}^N} (e_f(t, x) + \rho_f(t, x)), \\ E'_f &:= \sup_{(t, x) \in [0, T) \times \mathbb{T}^N} e'_f(t, x), & H_f &:= \sup_{(t, x) \in [0, T) \times \mathbb{T}^N} |h_f(t, x)|, \\ L_f^p &:= \sup_{(t, x) \in [0, T) \times \mathbb{T}^N} l_f^p(t, x), & W_f &:= \sup_{(t, x) \in [0, T) \times \mathbb{T}^N} w_f(t, x). \end{aligned}$$

Remark: In the spatially homogeneous setting all these quantities are independent of the space variable x and the uniformity in time is in most cases, well-known or obvious (see Section 5).

Our assumptions on the solution are as follows:

- When $\gamma \geq 0$ and $\nu < 0$ (hard or Maxwellian potentials with cutoff) we shall assume that

$$(1.6) \quad \varrho_f > 0, \quad E_f < +\infty, \quad H_f < +\infty.$$

³see Subsection 1.4 for the notations

- When $\gamma \in (-N, 0)$ (singularity of the kinetic collision kernel) we shall make the additional assumption that

$$(1.7) \quad L_f^{p_\gamma} < +\infty$$

with $p_\gamma > \frac{N}{N+\gamma}$ (notice that this uniform bound on $L_f^{p_\gamma}$ implies the one on the local entropy).

- When $\nu \in [0, 2)$ (singularity of the angular collision kernel) we shall make the additional assumption that

$$(1.8) \quad W_f < +\infty, \quad E'_f < +\infty$$

(remark that when $\gamma \leq 0$, we have $E'_f \leq E_f$ and the second part of this assumption is not necessary).

Remark: Although the regularity part of the last assumption (1.8) seems quite stronger compared to the other ones, the regularizing property of the non-cutoff collision operator often ensures that it holds, at least in some cases (see Section 5), and thus makes it rather natural.

We now state our main theorems. The first one deals with cutoff collision kernels. In this theorem a mild solution to the Boltzmann equation with initial datum f_0 is a function f which satisfies (3.1) pointwise (see Definition 3.1 below).

Theorem 1.1. *Let $B = \Phi b$ be a collision kernel which satisfies (1.1), with Φ satisfying (1.2) or (1.3), and b satisfying (1.4) with $\nu < 0$. Let $f(t, x, v)$ be a mild solution of the full Boltzmann equation in the torus on some time interval $[0, T)$, $T \in (0, +\infty]$ such that*

- (i) *if Φ satisfies (1.2) with $\gamma \geq 0$ or if Φ satisfies (1.3), then f satisfies (1.6);*
- (ii) *if Φ satisfies (1.2) with $\gamma < 0$, then f satisfies (1.6) and (1.7).*

Then for all $\tau \in (0, T)$ there exists some $\rho > 0$ and $\theta > 0$ depending on τ , ϱ_f , E_f , H_f (and $L_f^{p_\gamma}$ if Φ satisfies (1.2) with $\gamma < 0$), such that for all $t \in [\tau, T)$ the solution is bounded from below by the uniform Maxwellian distribution with density ρ and temperature θ , i.e.

$$(1.9) \quad \forall t \in [\tau, T), \quad \forall x \in \mathbb{T}^N, \quad \forall v \in \mathbb{R}^N, \quad f(t, x, v) \geq \rho \frac{e^{-\frac{|v|^2}{2\theta}}}{(2\pi\theta)^{N/2}}.$$

Remarks: Let us comment on the assumptions and conclusions of this theorem:

1. The main case of application of this theorem one should think of is $B = |v - v_*|^\gamma b(\cos \theta)$ with b bounded from above and below. It includes the hard spheres model (when $\gamma = 1$ and $b = 1$), and the so-called “variable hard spheres” model.

2. As the lower bound in (1.9) does not depend on the space variable x , Theorem 1.1 applies to spatially homogeneous solutions as well: take f_0 depending only on v and $f(t, v)$ the corresponding solution of the homogeneous Boltzmann equation, then $f(t, v)$ is also a solution of the inhomogeneous Boltzmann equation in the torus and Theorem 1.1 gives the appearance of a Maxwellian lower bound on the v variable. This theorem thus includes and

extends the previous result of Pulvirenti and Wennberg in [30], valid for hard potentials. It gives new results for spatially homogeneous solutions in the case of soft potentials with cutoff (see Section 5).

3. In the inhomogeneous case, Theorem 1.1 applies to the solutions of Ukai [33] near the equilibrium for hard spheres, or to the solutions of Guo [21] near the equilibrium for soft potentials with cutoff (see Section 5).

4. More generally this theorem can be seen as an *a priori* result on the renormalized solutions (see [14] and [8, Chapter 5]), the only theory of solutions in the large at now. For instance for a gas of hard spheres in a torus, its converse says that if the solution f vanishes, then either the local density ρ_f has to vanish somewhere in the torus, or the local density ρ_f , energy e_f or entropy h_f have to blow-up somewhere in the torus.

Now let us state the result we get for long-range interaction models, i.e. collision kernels with an angular singularity. In this theorem a mild solution to the Boltzmann equation with initial datum f_0 is a function f which satisfies (4.3) pointwise (see Definition 4.1 below).

Theorem 1.2. *Let $B = \Phi b$ be a collision kernel which satisfies (1.1), with Φ satisfying (1.2) or (1.3), and b satisfying (1.4) with $\nu \in [0, 2)$. Let $f(t, x, v)$ be a mild solution of the full Boltzmann equation in the torus on some time interval $[0, T)$, $T \in (0, +\infty]$ such that*

- (i) *if Φ satisfies (1.2) with $\gamma \geq 0$ or if Φ satisfies (1.3), then f satisfies (1.6) and (1.8);*
- (ii) *if Φ satisfies (1.2) with $\gamma < 0$, then f satisfies (1.6), (1.7) and (1.8).*

Then for all $\tau \in (0, T)$ and for any exponent K such that

$$K > 2 \frac{\log \left(2 + \frac{2\nu}{2-\nu} \right)}{\log 2},$$

there exist $C_1 > 0$ and $C_2 > 0$ depending on τ , K , ϱ_f , E_f , E'_f , H_f , W_f (and $L_f^{p_\gamma}$ if Φ satisfies (1.2) with $\gamma < 0$), such that

$$\forall t \in [\tau, T), \forall x \in \mathbb{T}^N, \forall v \in \mathbb{R}^N, \quad f(t, x, v) \geq C_1 e^{-C_2 |v|^K}.$$

Moreover in the case when $\nu = 0$, one can take $K = 2$ (Maxwellian lower bound).

Remarks: Let us comment on the assumptions and conclusions of this theorem:

1. One can check that this theorem is consistent with Theorem 1.1 when $\nu \rightarrow 0$. Notice that the situation when $\nu = 0$ is particular: the collision operator is non-cutoff and corresponds to some “logarithmic derivative”.

2. This theorem is, to the knowledge of the author, the first quantitative lower bound result for non-cutoff collision kernels. It applies for instance to the spatially homogeneous solutions recently obtained in [13] (see Section 5).

3. We mention that an extension of Theorem 1.1 and Theorem 1.2 to the case of a bounded open set Ω with specular reflection or bounce-back boundary condition on $\partial\Omega$ is in progress, and will be treated in a second part of this work.

1.3. Methods of proof. In the spatially homogeneous case the proof of [30] proceeds in two steps: first the construction of an “upheaval point” for the solution after a small time, i.e. a uniform minoration on a ball; second a “spreading process” of this bound from below after a small time by the collision process, iterated infinitely many times. Both these steps are based on a mixing property of the gain part of the collision operator, which is reminiscent of the regularization property of this gain part, discovered by Lions (see [24, 25] or [36, Chapter 2, Section 3.4] for a review). The second step was already present in [6] and systematically used in [30]. The main contributions of our paper are:

- (1) a strategy to deal with space dependent solutions (Section 3), based on an implementation of the “upheaval” and “spreading” steps along each characteristic, keeping track carefully of the constants in order to get uniform estimates according to the choice of the characteristic;
- (2) a strategy to deal with non cutoff collision kernels (Section 4), based on the use of a suitable splitting of the collision operator between a cutoff part which still enjoys the spreading property, and a small non-cutoff part, for which we give L^∞ estimates of smallness thanks to the regularity assumptions on the solution. A precise balance between these two parts then allows to obtain the lower bound in the non cutoff case, although slightly weaker;
- (3) the implementation of the general method for soft potentials as well (i.e for collision kernels with a singular kinetic part), and in any dimension (Sections 3 and 4);
- (4) a detailed discussion of the connection between these results and the existing Cauchy theories (Section 5).

Here we adopt the point of view of an *a priori* setting which allows to treat separately the issue of the lower bound and the one of establishing *a priori* estimates on the solution. Therefore we do not address the question of obtaining such *a priori* estimates in the general case, which is open at now. This point of view should be understood as a unified approach for all existing Cauchy theories, as well as a way to obtain *a priori* results when no Cauchy theory exists, or when the solutions are too weak.

The paper runs as follows. Section 2 remains purely functional, Section 3 and 4 work on arbitrary solutions in *a priori* setting, and only Section 5 deals with solutions which have effectively been constructed by previous authors. Section 3 is devoted to the proof of Theorem 1.1, Section 4 to the proof of Theorem 1.2 and Section 5 applies these two theorems to the existing Cauchy theories.

1.4. Notation. In the sequel we shall denote $\langle \cdot \rangle = \sqrt{1 + |\cdot|^2}$. We define the weighted Lebesgue space $L_q^p(\mathbb{R}^N)$ ($p \in [1, +\infty]$, $q \in \mathbb{R}$) by the norm

$$\|f\|_{L_q^p(\mathbb{R}^N)} = \left[\int_{\mathbb{R}^N} |f(v)|^p \langle v \rangle^{pq} dv \right]^{1/p}$$

if $p < +\infty$ and

$$\|f\|_{L_q^\infty(\mathbb{R}^N)} = \sup_{v \in \mathbb{R}^N} |f(v)| \langle v \rangle^q$$

when $p = +\infty$. The Sobolev space $W^{k,p}(\mathbb{R}^N)$ ($p \in [1, +\infty]$ and $k \in \mathbb{N}$) is defined by

$$\|f\|_{W^{k,p}(\mathbb{R}^N)} = \left[\sum_{|s| \leq k} \|\partial^s f(v)\|_{L^p}^p \right]^{1/p},$$

with the usual notation $H^k = W^{k,2}$. Concerning the collision kernel we define the L^1 norm of b on the unit sphere when $\nu < 0$ (integrable angular collision kernel) by

$$n_b = \int_{\mathbb{S}^{N-1}} b(\cos \theta) d\sigma = |\mathbb{S}^{N-2}| \int_0^\pi b(\cos \theta) \sin^{N-2} \theta d\theta,$$

and in the case $\nu \in [0, 2)$ we define

$$m_b = \int_{\mathbb{S}^{N-1}} b(\cos \theta) (1 - \cos \theta) d\sigma = |\mathbb{S}^{N-2}| \int_0^\pi b(\cos \theta) (1 - \cos \theta) \sin^{N-2} \theta d\theta,$$

which is always finite (since $\nu < 2$), and is related to the cross-section for momentum transfer (see [36, Chapter 1, Section 3.4]). Finally we define

$$\ell_b = \inf_{\pi/4 \leq \theta \leq 3\pi/4} b(\theta)$$

which is strictly positive by assumption.

In the following we shall keep track explicitly of the dependency of the constants according to the bounds on the collision kernel and the estimates on the solution. As a convention, “cst” shall systematically denote any constant depending only on the dimension N , γ , ν and b_0 . For a real x , we shall denote x^+ the positive part of x and we recall the shorthand $\tilde{\gamma} = (2 + \gamma)^+$.

2. FUNCTIONAL TOOLBOX

In this section we shall gather functional tools useful for the sequel. On one hand, Lemma 2.1, Lemma 2.5 are precised versions of well-known results adapted to our study: we need L^∞ estimates whereas the usual framework of such estimates are integral spaces. On the other hand, Lemma 2.3 and Lemma 2.4 are essentially generalizations of results in [30]. We extend these results for any cutoff potentials (in the sense of (1.2) and (1.4) with $\nu < 0$), in any dimension. Moreover we intend to use these results in the context of spatially inhomogeneous solutions, using the fact that the collision operator is local in t and x , which allows to see these variables as parameters in the functional estimates. Thus we shall track precisely the dependence of these estimates on the hydrodynamical quantities: $\rho_f, e_f, e'_f, h_f, l_f^p, w_f$.

2.1. The cutoff case. We introduce Grad's splitting

$$\begin{aligned} Q(g, f) &= Q^+(g, f) - Q^-(g, f) \\ Q^+(g, f) &:= \int_{\mathbb{R}^N} dv_* \int_{\mathbb{S}^{N-1}} d\sigma B(|v - v_*|, \cos \theta) g'_* f' \\ Q^-(g, f) &:= \int_{\mathbb{R}^N} dv_* \int_{\mathbb{S}^{N-1}} d\sigma B(|v - v_*|, \cos \theta) g_* f \end{aligned}$$

where Q^+ is called the gain term and Q^- is called the loss term. We write the loss term as

$$Q^-(g, f) = L[g] f$$

with

$$(2.1) \quad L[g(t, x, \cdot)](v) = n_b \int_{\mathbb{R}^N} \Phi(v - v_*) g(t, x, v_*) dv_*$$

First let us give an L^∞ bound on the action of the loss term along the characteristics.

Lemma 2.1. *Let g be a measurable function on \mathbb{R}^N . Then*

(i) *If Φ satisfy (1.2) with $\gamma \geq 0$ or if Φ satisfies (1.3), then*

$$\forall v \in \mathbb{R}^N, \quad |g * \Phi(v)| \leq \text{cst } C_\Phi \|g\|_{L^1_\frac{1}{2}} \langle v \rangle^{\gamma^+}.$$

(ii) *If Φ satisfy (1.2) with $\gamma < 0$, then*

$$\forall v \in \mathbb{R}^N, \quad |g * \Phi(v)| \leq \text{cst } C_\Phi \left[\|g\|_{L^1_\frac{1}{2}} + \|g\|_{L^p} \right] \langle v \rangle^{\gamma^+}.$$

with $p > N/(N + \gamma)$.

Corollary 2.2. *As a straightforward consequence we obtain the following estimates on the operators L and S defined respectively in (2.1) and (2.6)*

$$(2.2) \quad \forall v \in \mathbb{R}^N, \quad |L[g](v)| \leq C_L \langle v \rangle^{\gamma^+} \quad \text{and} \quad |S[g](v)| \leq C_S \langle v \rangle^{\gamma^+}$$

where the constants C_L and C_S are defined by:

(i) *If Φ satisfy (1.2) with $\gamma \geq 0$ or if Φ satisfies (1.3), then*

$$C_L = \text{cst } n_b C_\Phi e_g, \quad C_S = \text{cst } m_b C_\Phi e_g.$$

(ii) *If Φ satisfy (1.2) with $\gamma < 0$, then*

$$C_L = \text{cst } n_b C_\Phi [e_g + l_g^p], \quad C_S = \text{cst } m_b C_\Phi [e_g + l_g^p].$$

Proof of Lemma 2.1. In the case Φ satisfies (1.2) with $\gamma \geq 0$ or (1.3), the proof is obvious and amounts to a triangular inequality.

In the case Φ satisfies (1.2) with $\gamma \in (-N, 0)$, one can split $g * \Phi(v)$ into

$$\begin{aligned} g * \Phi(v) &= \int_{\{v_* ; |v-v_*| \leq 1\}} \Phi(v - v_*) g(v_*) dv_* \\ &\quad + \int_{\{v_* ; |v-v_*| \geq 1\}} \Phi(v - v_*) g(v_*) dv_* =: I_1 + I_2. \end{aligned}$$

On one hand,

$$\forall v \in \mathbb{R}^N, \quad |I_2(v)| \leq C_\Phi \|g\|_{L^1} \leq C_\Phi \|g\|_{L^2_2}$$

and on the other hand, by Cauchy-Schwarz inequality

$$\forall v \in \mathbb{R}^N, \quad |I_1(v)| \leq C_\Phi \left[\int_{\{v_*; |v-v_*| \leq 1\}} |v-v_*|^{\gamma p'} dv_* \right]^{1/p'} \|g\|_{L^p}$$

which gives the result since

$$\text{cst} = \int_{\{v_*; |v-v_*| \leq 1\}} |v-v_*|^{\gamma p'} dv_* = \int_{\{u; |u| \leq 1\}} |u|^{\gamma p'} du < +\infty$$

as soon as $\gamma p' > -N$, i.e $p > \frac{N}{N+\gamma}$. □

The next lemma uses the mixing property of Q^+ in order to obtain a minoration of $Q^+(Q^+(\cdot, \cdot), \cdot)$ on a ball. This will be the starting point for the construction of an ‘‘upheaval point’’ by the iterated Duhamel formula.

Lemma 2.3. *Let $B = \Phi b$ be a collision kernel which satisfies (1.1), with Φ satisfying (1.2) or (1.3), and b satisfying (1.4) with $\nu \leq 0$. Let $g(v)$ be a nonnegative function on \mathbb{R}^N with bounded energy e_g and entropy h_g and a mass ρ_g such that $0 < \rho_g < +\infty$. Then there exist $R_0 > 0$, $\delta_0 > 0$, $\eta_0 > 0$ and $\bar{v} \in B(0, R_0)$ such that*

$$Q^+(Q^+(g \mathbf{1}_{B(0, R_0)}, g \mathbf{1}_{B(0, R_0)}), g \mathbf{1}_{B(0, R_0)}) \geq \eta_0 \mathbf{1}_{B(\bar{v}, \delta_0)}$$

and R_0, δ_0, η_0 only depend on B , on a lower bound on ρ_g , and upper bounds on e_g and h_g .

Remark: Another strategy to obtain this ‘‘upheaval point’’ for hard potentials could have been to iterate the regularity property of Q^+ in the form proved in [29] in Sobolev spaces enough times to get some continuous function. We did not follow this method which is less direct, and leads to harder computations to track the exact dependence of the constant. Nevertheless the remark emphasizes the fact that the mixing property used here on Q^+ is a *linear* one, which is consistent with the regularity theory for this operator (see the regularity theory of Q^+ in the cutoff case in [29]).

Proof of Lemma 2.3. This lemma is a slight variant of [30, Lemma 3.1], whose proof can be straightforwardly adapted here. Note that this proof was made assuming that b is bounded below by a positive quantity on the whole interval $[0, \pi]$ but as pointed out in [30, Proof of Lemma 3.1] the proof still works the same under the sole assumption on b that it is bounded below by a positive quantity near $\theta \sim \pi/2$, which is satisfied under our assumptions on b .

Therefore we only generalize the formula in the proof to any dimension and to any power γ of the collision kernel, and we precise the dependence of R_0, δ_0 and η_0 according to the quantities ρ_g, e_g and h_g .

First let us suppose that Φ satisfies (1.2) with $\gamma \geq 0$, in order to satisfy the assumptions of [30, Lemma 3.1]. As for R_0 , in the proof of [30, Lemma 3.1] R_0 is chosen such that

$$\int_{|v| \leq R_0} g(v) dv \geq \frac{\rho_g}{2}.$$

The estimate

$$\int_{|v| \geq R_0} g(v) dv \leq \frac{e_g}{R_0^2}$$

yields the possible choice

$$R_0 = \sqrt{\frac{2e_g}{\rho_g}}.$$

Then it is straightforward to see that δ_0 depends only on upper bounds on e_g and h_g , and

$$\eta_0 = \text{cst } \ell_b c_\Phi R_0^{\gamma - (3N-1)} \delta_0^{2N}.$$

The case of a mollified kinetic collision kernel Φ (assumption (1.3)) with $\gamma \geq 0$ reduces to the case of a kinetic collision kernel satisfying (1.2) with $\gamma \geq 0$. Indeed when $\gamma \geq 0$, we have the bound from below $\Phi(z) \geq c_\Phi |z|^\gamma$ for all $z \in \mathbb{R}^N$ and the proof is unchanged.

When Φ satisfies (1.2) or (1.3) with $\gamma < 0$, we first choose R_0 as above, with $R_0 \geq 1$ (it is possible up to take a bigger R_0). Then we use that on $B(0, R_0)$, we have that $\Phi(z) \geq c_\Phi R_0^\gamma$, which means we can apply the formula above for the case $\gamma = 0$, and the final formula for η_0 is unchanged. \square

The next lemma gives a precise estimate of the ‘‘spreading property’’ of Q^+ (according to the velocity variable), which is pictured in Figure 1: for any $R' < \sqrt{r^2 + R^2}$, for any v in the ball with radius R' , it is possible to find collisions with post-collision velocity v, v_* and taking the pre-collision velocity v'_* inside the ball with radius R and the pre-collision velocity v' inside the ball with radius r .

Lemma 2.4. *Let $B = \Phi b$ be a collision kernel which satisfies (1.1), with Φ satisfying (1.2) or (1.3), and b satisfying (1.4) with $\nu \leq 0$. Then for any $\bar{v} \in \mathbb{R}^N$, $0 < r \leq R$, $\xi \in (0, 1)$, we have*

$$(2.3) \quad Q^+(\mathbf{1}_{B(\bar{v}, R)}, \mathbf{1}_{B(\bar{v}, r)}) \geq \text{cst } \ell_b c_\Phi r^{N-3} R^{3+\gamma} \xi^{N/2-1} \mathbf{1}_{B(\bar{v}, \sqrt{r^2 + R^2}(1-\xi))}.$$

As a consequence in the particular quadratic case $\delta = r = R$, we obtain

$$(2.4) \quad Q^+(\mathbf{1}_{B(\bar{v}, \delta)}, \mathbf{1}_{B(\bar{v}, \delta)}) \geq \text{cst } \ell_b c_\Phi \delta^{N+\gamma} \xi^{N/2-1} \mathbf{1}_{B(\bar{v}, \delta\sqrt{2}(1-\xi))}$$

for any $\bar{v} \in \mathbb{R}^N$ and $\xi \in (0, 1)$.

Remark: In the sequel we shall use the quadratic version of Lemma 2.4 (i.e when $r = R$) which seems compulsory when one wants to obtain the optimal Maxwellian decrease at infinity for the lower bound. Nevertheless we give a bilinear version since it highlights again the fact that the ‘‘spreading effect’’ of Q^+ is a linear one.

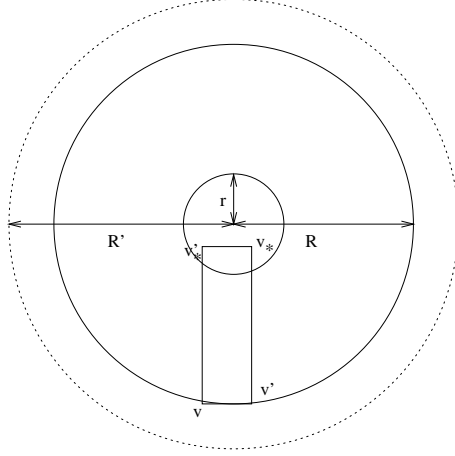
 FIGURE 1. Spreading property of Q^+

Proof of Lemma 2.4. This result is a bilinear version of [30, Lemma 3.2], written here in any dimension and for any power γ . Thus we only recall the main steps of the proof, especially those where the bilinearity, the dimension N , or γ play some role.

First we deal with collision kernel such that Φ satisfies (1.2) with $\gamma \geq 0$. As a general property Q^+ satisfies the homogeneity relation

$$Q^+(g, f)(\lambda v) = \lambda^{N+\gamma} Q^+(g(\lambda \cdot), f(\lambda \cdot))(v)$$

and the invariance by translation allows to reduce the proof of (2.3) to the proof of

$$Q^+(\mathbf{1}_{B(0,1)}, \mathbf{1}_{B(0,p)}) \geq \text{cst } \ell_b c_\Phi p^{N-3} \xi^{N/2-1} \mathbf{1}_{B(0, \sqrt{1+p^2}(1-\xi))}$$

with $p \leq 1$ stands for r/R . Now by isotropic invariance we can assume $v = z \mathbf{e}_N$ with $z < \sqrt{1+p^2}$ and $(\mathbf{e}_1, \dots, \mathbf{e}_N)$ an orthonormal basis. By Carleman representation [7], we have

$$Q^+(\mathbf{1}_{B(0,1)}, \mathbf{1}_{B(0,p)})(v = z \mathbf{e}_N) \geq c_\Phi \int_{v' \in \mathbb{R}^N} \frac{\mathbf{1}_{B(0,p)}(v')}{|v - v'|^{N-1-\gamma}} \left[\int_{v'_* \in E_{vv'}} \mathbf{1}_{B(0,1)}(v'_*) \tilde{b}(\theta) dv'_* \right] dv'$$

where $E_{vv'}$ is the hyperplan orthogonal to $v' - v$ and containing v . We write the integral along v' in spherical coordinates centered in v and we use the bound from below $\tilde{b}(\theta) = b(\theta) (\sin \theta/2)^{-\gamma} \geq \text{cst } \ell_b$ for $\theta \in [\pi/4, 3\pi/4]$ given by the assumptions on b

$$Q^+(\mathbf{1}_{B(0,1)}, \mathbf{1}_{B(0,p)})(v = z \mathbf{e}_N) \geq \text{cst } \ell_b c_\Phi \int_0^{+\infty} \int_{\mathbb{S}^{N-1}} \mathbf{1}_{B(0,r)}(v + \rho \sigma) \rho^\gamma \text{Vol}(E_{vv'} \cap B(0,1) \cap C_{v,\rho}) d\rho d\sigma,$$

where

$$\mathcal{C}_{v,\rho} = \left\{ u \in \mathbb{R}^N, \quad \tan \frac{\pi}{8} \rho \leq |u - v| \leq \tan \frac{3\pi}{8} \rho \right\}.$$

Finally it is easy to see that the integrand is invariant under rotation around the axis $(0, \mathbf{e}_N)$, which allows to simplify the part of integration over the unit sphere \mathbb{S}^{N-2} of the hyperplan orthogonal to $(0, \mathbf{e}_N)$:

$$\begin{aligned} Q^+(\mathbf{1}_{B(0,1)}, \mathbf{1}_{B(0,p)})(v = z \mathbf{e}_N) &\geq \\ \text{cst } \ell_b c_\Phi &\int_0^{+\infty} \int_0^\pi (\sin \alpha)^{N-2} \mathbf{1}_{B(0,r)}(v + \rho \sigma) \rho^\gamma \text{Vol}(E_{vv'} \cap B(0,1) \cap \mathcal{C}_{v,\rho}) d\rho d\alpha. \end{aligned}$$

where σ in the integrand stands for any $-(\cos \alpha) \mathbf{e}_N + (\sin \alpha) \mathbf{u}$ with \mathbf{u} is any vector of the set of unit vectors orthogonal to \mathbf{e}_N . Some elementary geometrical computation lead to

$$\text{Vol}(E_{vv'} \cap B(0,1)) = \text{cst} (1 - z^2 \cos^2 \alpha)^{\frac{N-1}{2}} \mathbf{1}_{\{\cos^2 \alpha \leq 1/z^2\}}$$

and shows that

$$E_{vv'} \cap B(0,1) \subset \mathcal{C}_{v,\rho}$$

when

$$a \left(z \sin \alpha + \sqrt{1 - z^2 \cos^2 \alpha} \right) \leq \rho \leq b \left(z \sin \alpha - \sqrt{1 - z^2 \cos^2 \alpha} \right)$$

with

$$a := \tan^{-1} \frac{3\pi}{8} < 1, \quad b := \tan^{-1} \frac{\pi}{8} > 1.$$

This inequality is possible as soon as

$$1 - z^2 \cos^2 \alpha \leq \lambda^2 z^2 \sin^2 \alpha$$

with $\lambda = (b - a)/(b + a) < 1$. If one sets $y = z \cos \alpha$ as a new variable, this inequality means

$$y \geq \sqrt{\frac{1 - \lambda^2 z}{1 - \lambda^2}}$$

and one gets

$$\begin{aligned} Q^+(\mathbf{1}_{B(0,1)}, \mathbf{1}_{B(0,p)})(v = z \mathbf{e}_N) &\geq \\ \text{cst } \ell_b c_\Phi &\int_{\max\left\{\sqrt{z^2-1}, \sqrt{\frac{1-\lambda^2 z^2}{1-\lambda^2}}\right\}}^1 \int_{\max\left\{y-\sqrt{1-z^2+y^2}, a(\sqrt{z^2-y^2}+\sqrt{1-y^2})\right\}}^{\min\left\{y+\sqrt{1-z^2+y^2}, b(\sqrt{z^2-y^2}-\sqrt{1-y^2})\right\}} \\ &\rho^\gamma \left(1 - \frac{y^2}{z^2}\right)^{\frac{N-3}{2}} (1 - y^2)^{\frac{N-1}{2}} dy d\rho. \end{aligned}$$

Now setting $z = \sqrt{1 + p^2}(1 - \xi)$ and computing an expansion of this expression according to ξ in the same way as in the end of the proof of [30, Lemma 3.2], one gets the following estimates:

$$(1 - y^2)^{\frac{N-1}{2}} = (2(1 + p^2)\xi)^{\frac{N-1}{2}} + O(\xi^{\frac{N+1}{2}})$$

$$(z^2 - y^2)^{\frac{N-3}{2}} = p^{N-3} + O(\xi)$$

$$\int_{\max\{y - \sqrt{1-z^2+y^2}, a(\sqrt{z^2-y^2} + \sqrt{1-y^2})\}}^{\min\{y + \sqrt{1-z^2+y^2}, b(\sqrt{z^2-y^2} - \sqrt{1-y^2})\}} \rho^\gamma d\rho = \sqrt{2(1+p^2)\xi - 2(1-y)} + O(\xi^{3/2}).$$

Then similar computations as in the proof of [30, Lemma 3.2] conclude the proof (for the integration on y , the condition $y \geq \sqrt{(1 - \lambda^2 z^2)/(1 - \lambda^2)}$ plays no role at the limit since $\sqrt{(1 - \lambda^2 z^2)/(1 - \lambda^2)} \rightarrow_{\xi \rightarrow 0} \text{cst} < 1$).

As for the previous lemma the case of a mollified kinetic collision kernel Φ (assumption (1.3)) with $\gamma \geq 0$ reduces the case of a kinetic collision kernel satisfying (1.2) with $\gamma \geq 0$ since we have the bound from below $\Phi(z) \geq c_\Phi |z|^\gamma$ for all $z \in \mathbb{R}^N$ and the proof is unchanged.

When Φ satisfies (1.2) or (1.3) with $\gamma < 0$, we use that on $B(0, R)$, we have that $\Phi(z) \geq c_\Phi R^\gamma$ (assuming $R \geq 1$ without restriction for the sequel) which means we can apply the formula above for the case $\gamma = 0$, and the final formula (2.3) is unchanged. \square

2.2. The non-cutoff case. The two lemmas below will be useful in the treatment of non-cutoff collisions kernels. They express the fact that non-grazing collisions constitute the dominant term of the collision operator as long as “spreading effect” is concerned. They are essentially based on the by now well-known idea of using symmetry-induced cancellations effects in order to deal with the angular singularity (see [35, 1, 2]).

In the case of non cutoff collision kernels, the usual Grad’s splitting $Q = Q^+ - Q^-$ does not make sense anymore. However, the following splitting still makes sense:

$$(2.5) \quad \begin{aligned} Q(g, f) &= \int_{\mathbb{R}^N} dv_* \int_{\mathbb{S}^{N-1}} d\sigma B g'_* (f' - f) + \left(\int_{\mathbb{R}^N} dv_* \int_{\mathbb{S}^{N-1}} d\sigma B (g'_* - g_*) \right) f \\ &=: Q^1 + Q^2 \end{aligned}$$

Thanks to the cancellation Lemma [1, Lemma 1], the operator Q^2 can be written

$$Q^2(g, f) = S[g] f$$

with

$$(2.6) \quad S[g](v) := |\mathbb{S}^{N-2}| \left(\int_0^{\pi/2} \sin^{N-2} \theta \left[\frac{1}{\cos^{N+\gamma}(\theta/2)} - 1 \right] b(\theta) d\theta \right) \Phi * g(v).$$

Corollary 2.2 gives L^∞ estimates (2.2) on S . Now let us turn to the L^∞ estimates for Q^1 .

Lemma 2.5. *Let $B = \Phi b$ be a collision kernel which satisfies (1.1), with Φ satisfying (1.2) or (1.3), and b satisfying (1.4) with $\nu \in [0, 2)$. Let f, g be measurable functions on \mathbb{R}^N . Then*

(i) *If Φ satisfy (1.2) with $2 + \gamma \geq 0$ or if Φ satisfies (1.3), then*

$$\forall v \in \mathbb{R}^N, \quad |Q^1(g, f)(v)| \leq \text{cst } m_b C_\Phi \|g\|_{L^1_{\tilde{\gamma}}} \|f\|_{W^{2,\infty}} \langle v \rangle^{\tilde{\gamma}}.$$

(ii) If Φ satisfy (1.2) with $2 + \gamma < 0$, then

$$\forall v \in \mathbb{R}^N, \quad |Q^1(g, f)(v)| \leq \text{cst } m_b C_\Phi \left[\|g\|_{L^{\frac{1}{\gamma}}} + \|g\|_{L^p} \right] \|f\|_{W^{2,\infty}} \langle v \rangle^{\tilde{\gamma}}.$$

with $p > N/(N + \gamma + 2)$.

Remarks: 1. In the treatment of Q^2 , the “derivative-like” difference $(f' - f)$ can be transferred to the angular part of the collision kernel by a process of change of variable which plays the same role as integration by part for classical differential operators. One can not do the same in Lemma 2.5 because there is no “decoupling” of the two arguments f and g .

2. The proof of Lemma 2.5 is based on a similar idea as cancellation lemmas in [35, 1, 2]. We make a Taylor expansion of $(f' - f)$ for small deviation angles in order to compensate for the grazing collision singularity of the collision kernel. However for smooth functions the quantity $(f' - f)$ compensate only for a singularity of order 1. Thus one has to use the symmetry of the collision sphere in order to compensate for strong singularities: to compensate for a singularity of order 2, one has to kill the first order term of the Taylor expansion of $(f' - f)$ by integrating on the $(N - 2)$ -dimensional sphere included in the collision sphere which is orthogonal to the vector $v - v_*$ and contains v' .

3. Note that Lemma 2.5 is reminiscent of [2, Proposition 4] which implies that the complete non cutoff operator Q satisfies the following inequality

$$\|Q(g, f)\|_{W^{-2,1}} \leq C \|g\|_{L^{\frac{1}{\gamma}}} \|f\|_{L^{\frac{1}{\gamma}}}$$

Essentially the difference is that Lemma 2.5 is intended to provide an L^∞ control. This is why it requires an L^p bound on the solution for soft potentials. The proof of [2, Proposition 4] uses a duality argument and the pre-post collisional change of variable to pass the “derivative-like” difference on the dual test function. The $(N - 2)$ -dimensional sphere on which cancellations occur does not appear explicitly in the representation formula as in our proof, but is rather implicit in a projection argument. Here we proceed directly, using Carleman representation.

Proof of Lemma 2.5. In order to isolate the exact sphere on which we want to use symmetry properties, we use the Carleman representation (exchanging the roles of v' and v'_*)

$$Q^1(g, f)(v) = \int_{\mathbb{R}^N} dv'_* \frac{g'_*}{|v - v'_*|^{N-1}} \int_{E_{v,v'_*}} dv' b(\cos \theta) \Phi(v - v_*) (f' - f)$$

where E_{v,v'_*} denotes the hyperplan orthogonal to the vector $v - v'_*$ and containing v . Now let us write the integration of the v' variable in spherical coordinate of center v , i.e $v' = v + \rho\sigma$ where $\rho \in \mathbb{R}_+$ and σ describes the $(N - 2)$ -dimensional unit sphere of E_{v,v'_*} , denoted by $\mathbb{S}_{v-v'_*}^{N-2}$.

$$Q^1(g, f)(v) = \int_{\mathbb{R}^N} dv'_* \frac{g'_*}{|v - v'_*|^{N-1}} \int_0^\infty d\rho b(\cos \theta) \Phi(v - v_*) \rho^{N-2} \left(\int_{\mathbb{S}_{v-v'_*}^{N-2}} d\sigma (f(v + \rho\sigma) - f(v)) \right).$$

Now let us study more precisely the quantity

$$I = \int_{\mathbb{S}_{v-v'_*}^{N-2}} d\sigma (f(v + \rho\sigma) - f(v)).$$

If ∇f denotes the gradient of f and $\nabla^2 f$ its Hessian matrix, one has the following Taylor expansion:

$$f(v + \rho\sigma) = f(v) + \rho(\nabla f(v) \cdot \sigma) + \frac{\rho^2}{2} \langle \nabla^2 f(v + \rho'\sigma) \cdot \sigma, \sigma \rangle$$

where $0 \leq \rho' \leq \rho$. By bounding the last term and taking the integral over σ , we get the estimate

$$\left| I - \rho \left(\int_{\mathbb{S}_{v-v'_*}^{N-2}} d\sigma (\nabla f(v) \cdot \sigma) \right) \right| \leq \frac{\rho^2}{2} |\mathbb{S}^{N-2}| \|f\|_{W^{2,\infty}}.$$

As the term involving ∇f vanishes by symmetry, we obtain

$$|I| \leq \frac{\rho^2}{2} |\mathbb{S}^{N-2}| \|f\|_{W^{2,\infty}}.$$

Thus we get for some function ϕ in $L_{\tilde{\gamma}}^1$

$$\begin{aligned} & \left| \int_{\mathbb{R}^N} Q^1(g, f)(v) \phi(v) dv \right| \\ & \leq \|f\|_{W^{2,\infty}} |\mathbb{S}^{N-2}| \int_{\mathbb{R}^N} dv \int_{\mathbb{R}^N} dv'_* \frac{g'_*}{|v - v'_*|^{N-1}} \int_0^\infty d\rho b(\cos \theta) \Phi(v - v_*) \frac{\rho^N}{2} |\phi(v)| \\ & \leq \|f\|_{W^{2,\infty}} \int_{\mathbb{R}^N} dv \int_{\mathbb{R}^N} dv'_* \frac{g'_*}{|v - v'_*|^{N-1}} \int_0^\infty d\rho \rho^{N-2} \int_{\mathbb{S}_{v-v'_*}^{N-2}} d\sigma b(\cos \theta) \Phi(v - v_*) \frac{\rho^2}{2} |\phi(v)| \\ & \leq C_\Phi \|f\|_{W^{2,\infty}} \int_{\mathbb{R}^{2N} \times \mathbb{S}^{N-1}} dv dv_* d\sigma b(\cos \theta) (\sin(\theta/2))^2 |v - v_*|^{2+\gamma} |g'_*| |\phi|. \end{aligned}$$

Finally we cut the integral in two parts, for $\theta \in [0, \pi/2]$ and for $\theta \in [\pi/2, \pi]$. For the first part we use the pre-postcollisional change of variable and the change of variable $(v, v_*, \sigma) \rightarrow (v', v_*, \sigma)$ used in the cancellation lemma [1, Lemma 1] whose jacobian is $\cos^{-(N+\gamma)}(\theta/2)$ and is thus smaller than $2^{\frac{N+\gamma}{2}}$ for $\theta \in [0, \pi/2]$. For the second part we use the change of variable $(v, v_*, \sigma) \rightarrow (v, v'_*, \sigma)$ whose jacobian is $\sin^{-(N+\gamma)}(\theta/2)$, which is smaller than $2^{\frac{N+\gamma}{2}}$ for $\theta \in [\pi/2, \pi]$. Thus we get

$$\begin{aligned} & \left| \int_{\mathbb{R}^N} Q^1(g, f)(v) \phi(v) dv \right| \leq \\ & C_\Phi 2^{\frac{N+\gamma}{2}} \|f\|_{W^{2,\infty}} \int_{\mathbb{R}^{2N} \times \mathbb{S}^{N-1}} dv dv_* d\sigma b(\cos \theta) (\sin(\theta/2))^2 |v - v_*|^{2+\gamma} |g_*| |\phi| \end{aligned}$$

and so, if Φ satisfy (1.2) with $2 + \gamma \geq 0$ or if Φ satisfies (1.3), we get

$$\left| \int_{\mathbb{R}^N} Q^1(g, f)(v) \phi(v) dv \right| \leq C_\Phi \frac{\|f\|_{W^{2,\infty}}}{2^{\frac{N+\gamma}{2}+1}} \left(\int_{\mathbb{S}^{N-1}} d\sigma b(\cos \theta) (1 - \cos \theta) \right) \|g\|_{L^{\frac{1}{\gamma}}} \|\phi\|_{L^{\frac{1}{\gamma}}},$$

and if Φ satisfy (1.2) with $2 + \gamma < 0$, then

$$\left| \int_{\mathbb{R}^N} Q^1(g, f)(v) \phi(v) dv \right| \leq C_\Phi \frac{\|f\|_{W^{2,\infty}}}{2^{\frac{N+\gamma}{2}+1}} \left(\int_{\mathbb{S}^{N-1}} d\sigma b(\cos \theta) (1 - \cos \theta) \right) \left[\|g\|_{L^{\frac{1}{\gamma}}} + \|g\|_{L^p} \right] \|\phi\|_{L^{\frac{1}{\gamma}}}.$$

Since this holds for all $\phi \in L^{\frac{1}{\gamma}}$, this yields the result by duality, with $\text{cst} = C_\Phi / (2^{\frac{N+\gamma}{2}+1})$. \square

3. PROOF OF THE LOWER BOUND IN THE CUTOFF CASE

In this section we shall prove Theorem 1.1. Since the collision operator is local in t and x , the idea of the proof is to apply first Lemma 2.3 and then Lemma 2.4 iterated on *each characteristic* of the free transport operator, in order first to obtain an upheaval point, and then to “spread” the minoration. It yields for each characteristic of the transport flow a Maxwellian lower bound with macroscopic velocity \bar{v} , temperature θ and density ρ depending on the characteristic. Then a uniform control on \bar{v} , θ and ρ yields the global Maxwellian lower bound. This control is based on the uniform bounds on the hydrodynamic quantities. The lower bound is also made uniform as $t \rightarrow +\infty$ thanks to these uniform bounds.

The main tool is the Duhamel representation formula, written along the characteristics (which reduce to lines in the case of periodic boundary conditions):

$$(3.1) \quad \begin{aligned} \forall t \in [0, T), \forall x \in \mathbb{T}^N, \forall v \in \mathbb{R}^N, \\ f(t, x + vt, v) = f_0(x, v) \exp \left(- \int_0^t L[f(s, x + vs, \cdot)](v) ds \right) \\ + \int_0^t \exp \left(- \int_s^t L[f(s', x + vs', \cdot)](v) ds' \right) Q^+[f(s, x + vs, \cdot), f(s, x + vs, \cdot)](v) ds \end{aligned}$$

where L was defined in (2.1). We define the concept of solution we shall use in the cutoff case, i.e. the concept of mild solutions (see [8, Section 5.3] for an analogous definition).

Definition 3.1. *Let f_0 be a measurable function non-negative almost everywhere on $\mathbb{T}^N \times \mathbb{R}^N$. A measurable function $f = f(t, x, v)$ on $[0, T) \times \mathbb{T}^N \times \mathbb{R}^N$ is a mild solution of the Boltzmann equation to the initial datum $f_0(x, v)$ if for almost every (x, v) in $\mathbb{T}^N \times \mathbb{R}^N$:*

$$t \mapsto L[f(t, x + vt, \cdot)](v), \quad t \mapsto Q^+[f(t, x + vt, \cdot), f(t, x + vt, \cdot)](v)$$

are in $L^1_{\text{loc}}([0; T))$, and for each $t \in [0, T)$, the equation (3.1) is satisfied and $f(t, x, v)$ is non-negative for almost every (x, v) .

Proposition 3.2. *Let $B = \Phi b$ be a collision kernel which satisfies (1.1), with Φ satisfying (1.2) or (1.3), and b satisfying (1.4) with $\nu < 0$. Let $f(t, x, v)$ be a mild solution of the full Boltzmann equation in the torus on some time interval $[0, T)$ ($T \in (0, +\infty]$), which satisfies*

- (i) *assumption (1.6) if Φ satisfies (1.2) with $\gamma \geq 0$ or if Φ satisfies (1.3),*
- (ii) *assumptions (1.6) and (1.7) if Φ satisfies (1.2) with $\gamma \in (-N, 0)$.*

Then for any fixed $\tau \in (0, T)$ and $x \in \mathbb{T}^N$, there exists some $R_0 > 0$ and some $\bar{v} \in B(0, R_0)$ such that

$$(3.2) \quad \forall n \geq 0, \forall t \in \left[\tau - \frac{\tau}{2^{n+1}}, \tau \right], \forall v \in \mathbb{R}^N, \quad f(t, x + vt, v) \geq a_n \mathbf{1}_{B(\bar{v}, \delta_n)}$$

with the induction formulae

$$a_{n+1} = \text{cst } C_e \frac{a_n^2 \delta_n^{\gamma+N} \xi_n^{N/2+1}}{2^{n+1}}$$

$$\delta_{n+1} = \sqrt{2} \delta_n (1 - \xi_n)$$

where $(\xi_n)_{n \geq 0}$ is any sequence in $(0, 1)$, $R_0 > 0$, $a_0 > 0$, $\delta_0 > 0$, C_e depend only on τ , B , ϱ_f , E_f and H_f (plus $L_f^{p_\gamma}$ if Φ satisfies (1.2) with $\gamma \in (-N, 0)$), and $\bar{v} \in B(0, R_0)$ depend on the same quantities plus x .

Proof of Proposition 3.2. Step 1: Initialization

We apply Lemma 2.3 to the right-hand side member of the Duhamel representation iterated twice. More precisely, the equation (3.1) yields on one hand

$$f(t, x + vt, v) \geq f_0(x, v) e^{-C_L t \langle v \rangle^{\gamma^+}}$$

and on the other hand

$$f(t, x + vt, v) \geq \int_0^t e^{-C_L (t-s) \langle v \rangle^{\gamma^+}} Q^+ [f(s, x + vs, \cdot), f(s, x + vs, \cdot)](v) ds.$$

If we iterate the latter, we get

$$f(t, x + vt, v) \geq \int_0^t e^{-C_L (t-s) \langle v \rangle^{\gamma^+}} Q^+ \left[\left(\int_0^s e^{-C_L (s-s') \langle v \rangle^{\gamma^+}} Q^+ [f(s', x + vs', \cdot), f(s', x + vs', \cdot)](\cdot) ds' \right), f(s, x + vs, \cdot) \right](v) ds.$$

Whenever φ is some function on \mathbb{R}^N , we denote by φ^{R_0} the truncation $\varphi \mathbf{1}_{|v| \leq R_0}$. We can bound from below by

$$\forall v \in \mathbb{R}^N, |v| \leq R_0, \quad f(t, x + vt, v) \geq Q^+ \left[Q^+ [f_0^{R_0}(x, \cdot), f_0^{R_0}(x, \cdot)], f_0^{R_0}(x, \cdot) \right](v) \\ \int_0^t e^{-C_L (t-s) R_0^{\gamma^+}} e^{-C_L s R_0^{\gamma^+}} \left(\int_0^s e^{-C_L (s-s') R_0^{\gamma^+}} e^{-2C_L s' R_0^{\gamma^+}} ds' \right) ds$$

and thus after some computation

$$\forall v \in \mathbb{R}^N, |v| \leq R_0, \quad f(t, x + vt, v) \geq e^{-C_L t R_0^{\gamma^+}} \frac{(1 - e^{-C_L t R_0^{\gamma^+}})^2}{2(C_L R_0^{\gamma^+})^2} Q^+ \left[Q^+ [f_0^{R_0}(x, \cdot), f_0^{R_0}(x, \cdot)], f_0^{R_0}(x, \cdot) \right] (v).$$

Then the use of Lemma 2.3 concludes the initialization $n = 0$ of the proof with

$$a_0 = e^{-C_L \tau R_0^{\gamma^+}} \frac{(1 - e^{-C_L (\tau/2) R_0^{\gamma^+}})^2}{2(C_L R_0^{\gamma^+})^2} \eta_0$$

where δ_0, R_0, η_0 depend on ϱ_f, E_f, H_f (as in the statement of Lemma 2.3) and \bar{v} depend on the same quantities plus x (via the function $f_0^{R_0}(x, \cdot)$).

Step 2: Proof of the induction

Now let us suppose that the induction property holds for n :

$$\forall t \in \left[\tau - \frac{\tau}{2^{n+1}}, \tau \right], \quad \forall v \in \mathbb{R}^N, \quad f(t, x + vt, v) \geq a_n \mathbf{1}_{B(\bar{v}, \delta_n)}.$$

The Duhamel representation yields the following lower bound

$$\forall t \in \left[\tau - \frac{\tau}{2^{n+2}}, \tau \right], \quad \forall v \in \mathbb{R}^N, \quad f(t, x + vt, v) \geq \int_{\tau - \frac{\tau}{2^{n+1}}}^{\tau - \frac{\tau}{2^{n+2}}} e^{-C_L (t-s) \langle v \rangle^{\gamma^+}} Q^+ (a_n \mathbf{1}_{B(\bar{v}, \delta_n)}, a_n \mathbf{1}_{B(\bar{v}, \delta_n)}) ds,$$

which easily leads to

$$\forall t \in \left[\tau - \frac{\tau}{2^{n+2}}, \tau \right], \quad \forall v \in \mathbb{R}^N, \quad f(t, x + vt, v) \geq e^{-C_L \frac{\tau}{2^{n+1}} \langle v \rangle^{\gamma^+}} \left(\frac{\tau}{2^{n+2}} \right) a_n^2 Q^+ (\mathbf{1}_{B(\bar{v}, \delta_n)}, \mathbf{1}_{B(\bar{v}, \delta_n)}).$$

Now the application of Lemma 2.4 gives

$$\forall t \in \left[\tau - \frac{\tau}{2^{n+2}}, \tau \right], \quad \forall v \in \mathbb{R}^N, \quad f(t, x + vt, v) \geq \text{cst } e^{-C_L \frac{\tau}{2^{n+1}} \langle v \rangle^{\gamma^+}} \left(\frac{\tau}{2^{n+2}} \right) a_n^2 \delta_n^{N+\gamma} \xi_n^{N/2-1} \mathbf{1}_{B(\bar{v}, \delta_n \sqrt{2}(1-\xi_n))}$$

and thus if $\delta_{n+1} = \delta_n \sqrt{2}(1-\xi_n)$, we get

$$\forall t \in \left[\tau - \frac{\tau}{2^{n+2}}, \tau \right], \quad \forall v \in \mathbb{R}^N, \quad f(t, x + vt, v) \geq \text{cst } e^{-C_L \langle R_0 \rangle^{\gamma^+}} \frac{\tau}{2^{n+1}} \delta_{n+1}^{\gamma^+} \left(\frac{\tau}{2^{n+2}} \right) a_n^2 \delta_n^{N+\gamma} \xi_n^{N/2-1} \mathbf{1}_{B(\bar{v}, \delta_{n+1})}.$$

As an easy induction shows, we have $\delta_n \leq \delta_0 2^{n/2}$ and so

$$C_L \langle R_0 \rangle^{\gamma^+} \frac{\tau}{2^{n+1}} \delta_{n+1}^{\gamma^+} \leq C_L \langle R_0 \rangle^{\gamma^+} \frac{\tau}{2^{n+1}} (\delta_0 2^{n/2})^{\gamma^+}$$

which is uniformly bounded from above since $\gamma \leq 1$. Thus the exponential term

$$e^{-C_L \langle R_0 \rangle^{\gamma^+} \frac{\tau}{2^{n+1}} \delta_{n+1}^{\gamma^+}}$$

is bounded from below uniformly by some constant $C_e > 0$. We deduce that

$$\forall t \in \left[\tau - \frac{\tau}{2^{n+2}}, \tau \right], \forall v \in \mathbb{R}^N, f(t, x + vt, v) \geq \text{cst } C_e \left(\frac{a_n^2}{2^{n+1}} \right) a_n^2 \delta_n^{N+\gamma} \xi_n^{N/2-1} \mathbf{1}_{B(\bar{v}, \delta_{n+1})}.$$

This concludes the proof. \square

Now we can apply Proposition 3.2 along the characteristics in order to prove Theorem 1.1.

Proof of Theorem 1.1. We shall divide the proof into three steps for the sake of clarity. Each step is embodied in a lemma. For these three lemmas we make the same assumptions on B and f as in Theorem 1.1.

Step 1: Choice of $(\xi_n)_{n \geq 0}$ and asymptotic behavior of $(a_n)_{n \geq 0}$

Lemma 3.3. *For any $x \in \mathbb{T}^N$ and $\tau \in (0, T)$, there exists $\bar{v}(x) \in B(0, R_0)$ and $\rho, \theta > 0$ such that*

$$(3.3) \quad \forall v \in \mathbb{R}^N, f(\tau, x + \tau v, v) \geq \rho \frac{e^{-\frac{|v-\bar{v}|^2}{2\theta}}}{(2\pi\theta)^{N/2}}.$$

The constants R_0, ρ, θ depend on τ, ϱ_f, E_f and H_f (and $L_f^{p_\gamma}$ if Φ satisfies (1.2) with $\gamma < 0$).

Proof of Lemma 3.3. Let us now chose the sequence $(\xi_n)_{n \geq 0}$. The most natural choice is a geometrical sequence $\xi_n = \xi^{n+1}$ for some $\xi \in (0, 1)$. With this choice we can estimate the asymptotic behaviour of the sequence $(\delta_n)_{n \geq 0}$. Explicitly

$$\delta_n = \delta_0 2^{n/2} (1 - \xi) (1 - \xi^2) \cdots (1 - \xi^n) = \delta_0 2^{n/2} \prod_{k=0}^n (1 - \xi^k)$$

and thus as $\xi \in (0, 1)$ one easily gets

$$\delta_n \geq c_\delta 2^{n/2}$$

where the constant c_δ depends on δ_0 and ξ . It follows that

$$\forall n \geq 0, \forall t \in \left[\tau - \frac{\tau}{2^{n+1}}, \tau \right], \forall v \in B(\bar{v}, c_\delta 2^{n/2}), f(t, x + vt, v) \geq a_n.$$

By plugging this into the expression of the Maxwellian distribution

$$\rho \frac{e^{-\frac{|v-\bar{v}|^2}{2\theta}}}{(2\pi\theta)^{N/2}}$$

we deduce that a sufficient condition to obtain (3.3) is the following lower bound on the coefficients a_n appearing in the minoration (3.2): $a_n \geq \alpha^{2^n}$ for some $\alpha \in (0, 1)$. Indeed the parameter θ can then be fixed such that

$$e^{-\frac{c_\delta^2}{2\theta}} \leq \alpha.$$

Afterwards one can fix the parameter ρ in order that

$$a_0 \geq \frac{\rho}{(2\pi\theta)^{N/2}}$$

for $|v - \bar{v}| \leq \delta_0$, which leads to (3.3).

Let us prove this bound from below on the sequence $(a_n)_{n \geq 0}$. If one denotes

$$\lambda_n = \frac{\delta_n^{\gamma+N} \xi_n^{N/2+1}}{2^{n+1}}$$

one gets explicitly

$$a_n = (\text{cst } C_e)^{2^n-1} \left[\lambda_{n-1} \lambda_{n-2}^2 \cdots \lambda_0^{2^{n-1}} \right] a_0^{2^n}.$$

As for the sequence $(\lambda_n)_{n \geq 0}$, we have $\lambda_n \geq \text{cst } \lambda^n$ with

$$\lambda = \frac{2^{(\gamma+N)/2} \xi^{N/2+1}}{2}$$

and so

$$a_n \geq (\text{cst } C_e)^{2^n-1} \lambda^{[(n-1)2^0 + (n-2)2^1 + \cdots + 02^{n-1}]} a_0^{2^n}.$$

If $\lambda > 1$ the proof is clearly finished. If $\lambda \in (0, 1)$ it remains to study the quantity

$$A_n = [(n-1)2^0 + (n-2)2^1 + \cdots + 02^{n-1}]$$

An easy computation shows that $A_n = 2^n - (n+1)$ and so $A_n \leq 2^n$. It yields $a_n \geq \alpha^{2^n}$ with $\alpha := \text{cst } C_e \lambda a_0$. \square

Step 2: Uniformization of the spatial dependence

Lemma 3.4. *For any $\tau \in (0, T)$, there exists $\rho', \theta' > 0$ such that*

$$(3.4) \quad \forall x \in \mathbb{T}^N, \forall v \in \mathbb{R}^N, \quad f(\tau, x, v) \geq \rho' \frac{e^{-\frac{|v|^2}{2\theta'}}}{(2\pi\theta')^{N/2}}.$$

The constants ρ', θ' depend on τ, ϱ_f, E_f and H_f (and $L_f^{p_\gamma}$ if Φ satisfies (1.2) with $\gamma \in (-N, 0)$).

Proof of Lemma 3.4. This step is straightforward: the right-member term in the estimate (3.3) depends on the space variable x only through $\bar{v}(x)$. However, as a consequence of Lemma 2.3, \bar{v} is always included in the ball $B(0, R_0)$ for some radius R_0 depending only on the *a priori* bounds on the solution. Thus

$$e^{-\frac{|v-\bar{v}|^2}{2\theta}} \geq e^{-\frac{|v|^2}{\theta}} e^{-\frac{R_0^2}{\theta}}$$

and the proof is complete up to the choice of some new parameters ρ', θ' : one can take $\theta' = \theta/2$ and

$$\rho' = \rho \frac{e^{-\frac{R_0^2}{\theta}}}{2^{N/2}}.$$

□

Step 3: Uniformization of the time dependence

Lemma 3.5. *For any $\tau > 0$, there exists $\rho', \theta' > 0$ such that*

$$\forall t \in [\tau, T), \forall x \in \mathbb{T}^N, \forall v \in \mathbb{R}^N, \quad f(t, x, v) \geq \rho' \frac{e^{-\frac{|v|^2}{2\theta'}}}{(2\pi\theta')^{N/2}}.$$

The constants ρ', θ' depend on the a priori bounds on the solution.

Proof of Lemma 3.5. Again this step is straightforward: one can check that the lower bound (3.4) does not depend on the precise form of the solution $f(t, x, v)$ for $t \in [0, \tau]$, $x \in \mathbb{T}^N$, $v \in \mathbb{R}^N$, but only on the uniform bounds. It means that the same argument could be started not from $t = 0$ anymore, but at any time (as long as the bounds used are uniform in time). As the lower bound appears after some time $\tau > 0$ (arbitrary small), we get the lower bound for any time $t \geq \tau$ by making the proof start at $t - \tau$. □

This concludes the proof of Theorem 1.1. □

4. PROOF OF THE LOWER BOUND IN THE NON-CUTOFF CASE

In this section we shall prove Theorem 1.2. Again we use the spreading property along each characteristic but we use the spreading property on the gain part of a truncated collision operator. The remaining part will be treated thanks to the L^∞ estimates proved in Section 2.

We assume that $\nu \in [0, 2)$ and we make the following splitting for any $\varepsilon \in (0, \pi/4)$:

$$Q = Q_\varepsilon^+ - Q_\varepsilon^- + Q_\varepsilon^1 + Q_\varepsilon^2$$

where Q_ε^+ and Q_ε^- are the usual Grad splitting for the collision operator with collision kernel

$$B_\varepsilon^S := \Phi [b \mathbf{1}_{|\theta| \geq \varepsilon}] =: \Phi b_\varepsilon^S,$$

and Q_ε^1 and Q_ε^2 are the splitting introduced in (2.5) applied to the non-cutoff collision operator with collision kernel

$$B_\varepsilon^R := \Phi [b \mathbf{1}_{|\theta| \leq \varepsilon}] =: \Phi b_\varepsilon^R.$$

For the sake of clarity the index ε shall be recalled on each quantity that depends on this splitting.

It is straightforward to check that $b_\varepsilon^S \geq \ell_b$ on $[\pi/4, 3\pi/4]$, since $b_\varepsilon^S = b$ for $\theta \in [\pi/4, 3\pi/4]$ and thus the constants given by the application of Lemma 2.3 and Lemma 2.4 on Q_ε^+ are uniform according to ε . Moreover we have

$$(4.1) \quad n_{b_\varepsilon^S} \sim_{\varepsilon \rightarrow 0} \frac{b_0}{\nu} \varepsilon^{-\nu}, \quad m_{b_\varepsilon^R} \sim_{\varepsilon \rightarrow 0} \frac{b_0}{2-\nu} \varepsilon^{2-\nu}$$

for $\nu \in (0, 2)$ and

$$(4.2) \quad n_{b_\varepsilon^S} \sim_{\varepsilon \rightarrow 0} b_0 |\log \varepsilon|, \quad m_{b_\varepsilon^R} \sim_{\varepsilon \rightarrow 0} \frac{b_0}{2-\nu} \varepsilon^2$$

when $\nu = 0$.

The basic tool is the Duhamel formula written in the following way

$$(4.3) \quad \begin{aligned} \forall t \in [0, T], \forall x \in \mathbb{T}^N, \forall v \in \mathbb{R}^N, \\ f(t, x + vt, v) = f_0(x, v) \exp \left(- \int_0^t (S_\varepsilon + L_\varepsilon)[f(s, x + vs, \cdot)](v) ds \right) \\ + \int_0^t \exp \left(- \int_s^t (S_\varepsilon + L_\varepsilon)[f(s', x + vs', \cdot)](v) ds' \right) \\ (Q_\varepsilon^+ + Q_\varepsilon^1)[f(s, x + vs, \cdot), f(s, x + vs, \cdot)](v) ds \end{aligned}$$

where L_ε and S_ε are the operators introduced in Section 2 corresponding respectively to Q_ε^- and Q_ε^2 . We shall systematically use the L^∞ estimates given by (2.2) and Lemma 2.5, written in the following form

$$L_\varepsilon[f] \leq C_f n_{b_\varepsilon^S} \langle v \rangle^{\gamma^+}, \quad S_\varepsilon[f] \leq C_f m_{b_\varepsilon^R} \langle v \rangle^{\gamma^+}, \quad Q_\varepsilon^1(f, f) \leq C_f m_{b_\varepsilon^R} \langle v \rangle^{(2+\gamma)^+}$$

for a constant C_f depending on the uniform bounds on f .

Let us define the concept of mild solution we shall use in the non-cutoff case.

Definition 4.1. *Let f_0 be a measurable function non-negative almost everywhere on $\mathbb{T}^N \times \mathbb{R}^N$. A measurable function $f = f(t, x, v)$ on $[0, T) \times \mathbb{T}^N \times \mathbb{R}^N$ is a mild solution of the Boltzmann equation to the initial datum $f_0(x, v)$ if there exists $\varepsilon_0 > 0$ such that for all $0 < \varepsilon < \varepsilon_0$, for almost every (x, v) in $\mathbb{T}^N \times \mathbb{R}^N$:*

$$\begin{aligned} t \mapsto Q_\varepsilon^+[f(t, x + vt, \cdot), f(t, x + vt, \cdot)](v), \quad t \mapsto Q_\varepsilon^1[f(t, x + vt, \cdot), f(t, x + vt, \cdot)](v), \\ t \mapsto L_\varepsilon[f(t, x + vt, \cdot)](v), \quad t \mapsto S_\varepsilon[f(t, x + vt, \cdot)](v) \end{aligned}$$

are in $L_{\text{loc}}^1([0; T))$, and for each $t \in [0, T)$, the equation (4.3) is satisfied and $f(t, x, v)$ is non-negative for almost every (x, v) .

Let us prove the equivalent of Proposition 3.2 in the non cutoff case. Here we shall write the induction formula for a general sequence of time intervals Δ_n .

Indeed, on one hand at each step n of the induction the spreading effect of the gain part Q_ε^+ is now balanced by the perturbation Q_ε^1 , which imposes a careful choice of the splitting parameter ε for each n to get a lower bound on

$$Q_\varepsilon^+(f, f) + Q_\varepsilon^1(f, f) \geq Q_\varepsilon^+(f, f) - |Q_\varepsilon^1(f, f)|.$$

This yields a sequence $(\varepsilon_n)_{n \geq 0}$ going to 0 as n goes to infinity.

On the other hand at each step n of the induction we have the following action of $-Q_\varepsilon^- + Q_\varepsilon^2$ along the characteristic in the estimate from below on the solution:

$$e^{-C_f (m_{b_{\varepsilon_n}^R} + n_{b_{\varepsilon_n}^S}) (\sum_{k \geq n+1} \Delta_k) \langle v \rangle^{\gamma^+}}.$$

It makes the lower bound decrease and this exponential term goes to 0 when the splitting parameter ε goes to 0 (since $n_{b_{\varepsilon_n}^S}$ goes to infinity as ε goes to 0). That is why we shall choose time intervals Δ_n whose size decreases very fast to 0 as n goes to infinity, in order to limit the action of this part during a time interval.

Proposition 4.2. *Let $B = \Phi b$ be a collision kernel which satisfies (1.1), with Φ satisfying (1.2) or (1.3), and b satisfying (1.4) with $\nu \in [0, 2)$. Let $f(t, x, v)$ be a mild solution of the full Boltzmann equation in the torus on some time interval $[0, T)$ ($T \in (0, +\infty)$), which satisfies*

- (i) *assumptions (1.6) and (1.8) if Φ satisfies (1.2) with $\gamma \geq 0$ or if Φ satisfies (1.3);*
- (ii) *assumptions (1.6), (1.7) and (1.8) if Φ satisfies (1.2) with $\gamma \in (-N, 0)$.*

Then for any fixed $\tau \in (0, T)$ (small enough) and $x \in \mathbb{T}^N$, any sequence $(\Delta_n)_{n \geq 0}$ of positive numbers such that $\sum_{n \geq 0} \Delta_n = 1$, there exists some $R_0 > 0$ and $\bar{v} \in B(0, R_0)$ such that

$$\forall n \geq 0, \forall t \in \left[\left(\sum_{k=0}^n \Delta_k \right) \tau, \tau \right], \forall v \in \mathbb{R}^N, \quad f(t, x + vt, v) \geq a_n \mathbf{1}_{B(\bar{v}, \delta_n)}.$$

The sequence a_n satisfies the induction formula

$$(4.4) \quad a_{n+1} = \text{cst } \Delta_{n+1} \exp \left[- [C_f a_n^2 \delta_n^{N+\gamma-\tilde{\gamma}} \xi_n^{(N/2-1)}]^{-\frac{\nu}{2-\nu}} \left(\sum_{k \geq n+1} \Delta_k \right) \delta_{n+1}^{\gamma^+} \right] a_n^2 \delta_n^{\gamma+N} \xi_n^{(N/2+1)}$$

if $\nu \in (0, 2)$ and

$$(4.5) \quad a_{n+1} = \text{cst } \Delta_{n+1} \exp \left[- \text{cst } \log [C_f a_n^2 \delta_n^{N+\gamma-\tilde{\gamma}} \xi_n^{(N/2-1)}] \left(\sum_{k \geq n+1} \Delta_k \right) \delta_{n+1}^{\gamma^+} \right] a_n^2 \delta_n^{\gamma+N} \xi_n^{(N/2+1)}$$

if $\nu = 0$. The sequence δ_n satisfies the induction formula

$$\delta_{n+1} = \sqrt{2} \delta_n (1 - \xi_n).$$

Here $(\xi_n)_{n \geq 0}$ is any sequence in $(0, 1)$, the constants $R_0 > 0$, $a_0 > 0$, $\delta_0 > 0$ and C_f depend only on τ , ρ_f , E_f , E'_f , H_f , W_f (plus $L_f^{p_\gamma}$ if Φ satisfies (1.2) with $\gamma \in (-N, 0)$), and $\bar{v} \in B(0, R_0)$ depends on the same quantities plus x .

Proof of Proposition 4.2. In this proof we shall use estimates of Section 2 as well as several equations established in the proofs of Section 3.

Step 1: Initialization

The initialization here is simpler than for the cutoff case since we assume some regularity on the solution, and thus we do not need the regularizing property of the iterated gain term. First we give a straightforward lemma:

Lemma 4.3. *Let g a non-negative function on \mathbb{R}^N such that e_g and w_g are bounded, and ρ_g satisfies $0 < \rho_g < +\infty$. Then there are $R_0, \delta_0, \eta > 0$ and $\bar{v} \in B(0, R_0)$ such that*

$$g(v) \geq \eta \mathbf{1}_{B(\bar{v}, \delta_0)},$$

where $R_0, \delta_0, \eta > 0$ are explicit constants depending on the upper bounds on ρ_g, e_g, w_g and the lower bound on ρ_g .

Proof of Lemma 4.3. Using the bound on the energy of g , the choice

$$R_0 = \sqrt{\frac{2e_g}{\rho_g}}$$

implies that

$$\int_{|v| \leq R_0} g(v) dv \geq \frac{\rho_g}{2}.$$

So there is $\bar{v} \in B(0, R_0)$ such that

$$g(\bar{v}) \geq \frac{\rho_g}{2 \text{Vol}(B(0, R_0))}.$$

As w_g controls the Lipschitz norm, we have

$$\forall v_1, v_2 \in \mathbb{R}^N, \quad |g(v_1) - g(v_2)| \leq w_g |v_1 - v_2|$$

and thus if we take

$$\delta_0 = \frac{\rho_g}{4 \text{Vol}(B(0, R_0)) w_g}, \quad \eta = \frac{\rho_g}{4 \text{Vol}(B(0, R_0))},$$

we get $g(v) \geq \eta \mathbf{1}_{B(\bar{v}, \delta_0)}$. □

Now we fix $x \in \mathbb{T}^N$ and we deduce from the representation (4.3) that

$$\begin{aligned} \forall t \in [0, \tau], \forall v \in \mathbb{R}^N, \quad f(t, x + vt, v) &\geq f_0(x, v) e^{-\int_0^t (S_\varepsilon + L_\varepsilon)[f(s, x + vs, \cdot)](v) ds} \\ &+ \int_0^t e^{-\int_s^t (S_\varepsilon + L_\varepsilon)[f(s', x + vs', \cdot)](v) ds'} Q_\varepsilon^1[f(s, x + vs, \cdot), f(s, x + vs, \cdot)](v) ds. \end{aligned}$$

We apply Lemma 4.3 to the function $f_0(x, \cdot)$ to obtain

$$\begin{aligned} \forall t \in [0, \tau], \forall v \in \mathbb{R}^N, \quad f(t, x + vt, v) &\geq \eta \mathbf{1}_{B(\bar{v}, \delta_0)} e^{-\int_0^t (S_\varepsilon + L_\varepsilon)[f(s, x + vs, \cdot)](v) ds} \\ &+ \int_0^t e^{-\int_s^t (S_\varepsilon + L_\varepsilon)[f(s', x + vs', \cdot)](v) ds'} Q_\varepsilon^1[f(s, x + vs, \cdot), f(s, x + vs, \cdot)](v) ds. \end{aligned}$$

for some $\bar{v} \in B(0, R_0)$. Then we restrict the inequality on the ball $B(\bar{v}, \delta_0) \subset B(0, R_0 + \delta_0)$ and we use the estimates on S_ε , L_ε and Q_ε^1 to get

$$\forall t \in [0, \tau], \forall v \in B(\bar{v}, \delta_0), \quad f(t, x + vt, v) \geq \eta \mathbf{1}_{B(\bar{v}, \delta_0)} e^{-C_f (m_{b_\varepsilon^R} + n_{b_\varepsilon^S}) \langle v \rangle^{\gamma^+} \tau} - \tau C_f m_{b_\varepsilon^R} \langle v \rangle^{\tilde{\gamma}}.$$

Using the bounds on the velocity in the ball we get (up to modifying the constant C_f)

$$\forall t \in [0, \tau], \forall v \in B(\bar{v}, \delta_0), \quad f(t, x + vt, v) \geq \eta \mathbf{1}_{B(\bar{v}, \delta_0)} e^{-C_f (m_{b_\varepsilon^R} + n_{b_\varepsilon^S}) \tau} - \tau C_f m_{b_\varepsilon^R}.$$

Then we assume (up to reducing τ) that $\tau \leq 1$, and we choose first ε_0 small enough such that

$$C_f m_{b_{\varepsilon_0}^R} \leq \frac{\eta}{4}$$

and then τ small enough such that

$$e^{-C_f (m_{b_{\varepsilon_0}^R} + n_{b_{\varepsilon_0}^S}) \tau} \geq \frac{1}{2}.$$

This shows that

$$\forall t \in [0, \tau], \forall v \in B(\bar{v}, \delta_0), \quad f(t, x + vt, v) \geq \frac{\eta}{4} \mathbf{1}_{B(\bar{v}, \delta_0)},$$

which concludes the initialization with \bar{v} , δ_0 and $\eta_0 = \eta/4$.

Step 2: Proof of the induction

As for the proof of the induction, we proceed quite similarly as in the proof of Proposition 3.2. We suppose that the n th step is satisfied:

$$\forall t \in \left[\left(\sum_{k=0}^n \Delta_k \right) \tau, \tau \right], \forall v \in \mathbb{R}^N, \quad f(t, x + vt, v) \geq a_n \mathbf{1}_{B(\bar{v}, \delta_n)}.$$

We use the following lower bound given by the Duhamel representation (4.3) and the estimate on Q_ε^1 :

$$\forall t \in \left[\left(\sum_{k=0}^{n+1} \Delta_k \right) \tau, \tau \right], \forall v \in \mathbb{R}^N, \quad f(t, x + vt, v) \geq \int_{(\sum_{k=0}^n \Delta_k) \tau}^t e^{-C_f (m_{b_\varepsilon^R} + n_{b_\varepsilon^S}) (t-s) \langle v \rangle^{\gamma^+}} \left[Q_\varepsilon^+(a_n \mathbf{1}_{B(\bar{v}, \delta_n)}, a_n \mathbf{1}_{B(\bar{v}, \delta_n)}) - \tau C_f m_{b_\varepsilon^R} \langle v \rangle^{\tilde{\gamma}} \right] ds.$$

Thus by applying Lemma 2.4 on Q_ε^+ , we obtain

$$\forall t \in \left[\left(\sum_{k=0}^{n+1} \Delta_n \right) \tau, \tau \right], \forall v \in \mathbb{R}^N,$$

$$f(t, x + vt, v) \geq \int_{(\sum_{k=0}^n \Delta_n) \tau}^t e^{-C_f (m_{b_\varepsilon^R} + n_{b_\varepsilon^S}) (t-s) \langle v \rangle^{\gamma^+}} \left[\text{cst } a_n^2 \delta_n^{N+\gamma} \xi_n^{(N/2-1)} \mathbf{1}_{B(\bar{v}, \delta_{n+1})} - \tau C_f m_{b_\varepsilon^R} \langle v \rangle^{\tilde{\gamma}} \right].$$

Then we restrict the inequality to the ball $B(\bar{v}, \delta_{n+1})$ to obtain, using the bounds on the velocity and up to modifying the constant C_f :

$$\forall t \in \left[\left(\sum_{k=0}^{n+1} \Delta_n \right) \tau, \tau \right], \forall v \in B(\bar{v}, \delta_{n+1}),$$

$$f(t, x + vt, v) \geq \int_{(\sum_{k=0}^n \Delta_n) \tau}^t e^{-C_f (m_{b_\varepsilon^R} + n_{b_\varepsilon^S}) (t-s) \delta_{n+1}^{\gamma^+}} \left[\text{cst } a_n^2 \delta_n^{N+\gamma} \xi_n^{(N/2-1)} \mathbf{1}_{B(\bar{v}, \delta_{n+1})} - \tau C_f m_{b_\varepsilon^R} \delta_{n+1}^{\tilde{\gamma}} \right].$$

Then (assuming $\tau \leq 1$) we choose $\varepsilon = \varepsilon_n$ such that

$$\tau C_f m_{b_\varepsilon^R} \delta_{n+1}^{\tilde{\gamma}} \leq \frac{1}{2} \text{cst } a_n^2 \delta_n^{N+\gamma} \xi_n^{(N/2-1)}$$

which is possible since $m_{b_\varepsilon^R} \rightarrow_{\varepsilon \rightarrow 0} 0$. More precisely by using the equivalent of $m_{b_\varepsilon^R}$ for $\varepsilon \sim 0$, simple computations show that we can take

$$\varepsilon_n = \text{cst} \left[C_f a_n^2 \delta_n^{N+\gamma-\tilde{\gamma}} \xi_n^{(N/2-1)} \right]^{\frac{1}{2-\nu}}$$

where the constant C_f is independent of n and depends only on the uniform bounds on f .

Then we restrict the time integration to the interval $[(\sum_{k=0}^{n+1} \Delta_n) \tau, (\sum_{k=0}^{n+1} \Delta_n) \tau]$ (since the integrand is non-negative) which yields

$$\forall t \in \left[\left(\sum_{k=0}^{n+1} \Delta_n \right) \tau, \tau \right], \forall v \in B(\bar{v}, \delta_{n+1}),$$

$$f(t, x + vt, v) \geq \text{cst} \int_{(\sum_{k=0}^n \Delta_n) \tau}^{(\sum_{k=0}^{n+1} \Delta_n) \tau} e^{-C_f (m_{b_{\varepsilon_n}^R} + n_{b_{\varepsilon_n}^S}) (t-s) \delta_{n+1}^{\gamma^+}} a_n^2 \delta_n^{N+\gamma} \xi_n^{(N/2-1)} \mathbf{1}_{B(\bar{v}, \delta_{n+1})}$$

$$\geq \text{cst} e^{-C_f (m_{b_{\varepsilon_n}^R} + n_{b_{\varepsilon_n}^S}) (\sum_{k \geq n+1} \Delta_k) \delta_{n+1}^{\gamma^+}} \Delta_{n+1} a_n^2 \delta_n^{N+\gamma} \xi_n^{(N/2-1)} \mathbf{1}_{B(\bar{v}, \delta_{n+1})}.$$

Finally the argument in the exponential is seen to be equivalent to

$$\left[C_f a_n^2 \delta_n^{N+\gamma-\tilde{\gamma}} \xi_n^{(N/2-1)} \right]^{-\frac{\nu}{2-\nu}} \left(\sum_{k \geq n+1} \Delta_k \right) \delta_{n+1}^{\gamma^+}$$

when $\nu \in (0, 2)$ and

$$-\text{cst} \log \left[C_f a_n^2 \delta_n^{N+\gamma-\tilde{\gamma}} \xi_n^{(N/2-1)} \right] \left(\sum_{k \geq n+1} \Delta_k \right) \delta_{n+1}^{\gamma^+}$$

when $\nu = 0$ (for some new constant C_f depending on the uniform bounds on f), which concludes the proof. \square

We are now able to conclude the proof of Theorem 1.2.

Proof of Theorem 1.2. We only study the asymptotic behavior of the coefficients a_n . The two other steps of the proof (uniformization of the spatial and time dependences) are exactly similar as those in the proof of Theorem 1.1.

We fix $\xi \in (0, 1)$ and define $\xi_n = \xi^n$. We saw above that with this choice $\delta_n \sim \text{cst} 2^{n/2}$. First we deal with the case $\nu > 0$. Let us choose any $\kappa > 2 + 2\nu/(2 - \nu)$, and take for the time intervals

$$\Delta_{n+1} = \frac{\alpha^{\beta \kappa^n}}{\sum_{k \geq 0} \alpha^{\beta \kappa^{k-1}}}$$

where $\alpha \in (0, 1)$ and $2\nu/(2 - \nu) < \beta < \kappa - 2$. We shall establish by induction the lower bound

$$(4.6) \quad a_n \geq \alpha^{\kappa^n}.$$

One easily sees that this estimate (4.6) implies that

$$\forall v \in \mathbb{R}^N, \quad f(\tau, x + \tau v, v) \geq C_1 e^{-C_2 |v|^K}$$

for a suitable choice of $C_1, C_2 > 0$ and

$$K = \frac{\log \kappa}{\log \sqrt{2}},$$

and thus concludes the proof.

The initialization of the induction is made by choosing α such that $\alpha \leq a_0$. Then we suppose the lower bound satisfied for a_n and we show first that the argument of the exponential in (4.4) is uniformly bounded. A simple computation establishes that

$$\sum_{k \geq n+1} \Delta_k \leq \text{cst} \Delta_{n+1} = \text{cst} \alpha^{\beta \kappa^n}$$

where the constant is independent of n . Thus

$$\begin{aligned} \left[a_n^2 \delta_n^{N+\gamma-\tilde{\gamma}} \xi_n^{(N/2-1)} \right]^{-\frac{\nu}{2-\nu}} \left(\sum_{k \geq n+1} \Delta_k \right) \delta_{n+1}^{\gamma^+} \\ \leq \left[\frac{2^{\gamma^+/2}}{(C_f 2^{(N+\gamma-\tilde{\gamma})/2} \xi^{(N/2-1)})^{\nu/(2-\nu)}} \right]^n \alpha^{(\beta - \frac{2\nu}{2-\nu}) \kappa^n} \end{aligned}$$

and the right-hand side member of this inequality goes to 0 as n goes to infinity. So the exponential term is uniformly bounded from below by some constant $C_e > 0$ depending on the uniform bounds on the solution f .

So the induction formula (4.4) defining a_n yields

$$a_{n+1} \geq \text{cst } C_e \Delta_{n+1} a_n^2 \delta_n^{\gamma+N} \xi_n^{(N/2-1)}$$

and thus

$$a_{n+1} \geq \text{cst } C_e \alpha^{(2+\beta)\kappa^n} \left[2^{(N+\gamma)/2} \xi^{(N/2-1)} \right]^n \geq \text{cst } \alpha^{\kappa^{n+1}}$$

if α is small enough (using $\kappa > 2 + \beta$) and the induction is proved.

Now for the case $\nu = 0$, we choose the following time intervals

$$\Delta_{n+1} = \frac{\beta^n}{\sum_{k \geq 0} \beta^{k-1}}$$

where $\beta \in (0, 1)$. We shall establish by induction the lower bound

$$a_n \geq \alpha^{2^n}$$

which implies (as in the proof of Theorem 1.1) that

$$\forall v \in \mathbb{R}^N, \quad f(\tau, x + \tau v, v) \geq C_1 e^{-C_2 |v|^2}$$

for a suitable choice of $C_1, C_2 > 0$ and thus concludes the proof.

We suppose the lower bound satisfied for a_n and we show first that the argument of the exponential in (4.5) is uniformly bounded. We have

$$\sum_{k \geq n+1} \Delta_k \leq \text{cst } \Delta_{n+1} = \text{cst } \beta^n$$

where the constant is independent of n , and so

$$\begin{aligned} \left| \log \left[C_f a_n^2 \delta_n^{N+\gamma-\tilde{\gamma}} \xi_n^{(N/2-1)} \right] \left(\sum_{k \geq n+1} \Delta_k \right) \delta_{n+1}^{\gamma^+} \right| \\ \leq |\log C_f| + \text{cst } 2^{n(\gamma^+/2+1)} \beta^n + \text{cst } n 2^{n\gamma^+/2} \beta^n \end{aligned}$$

which goes to 0 if β is taken small enough. So the exponential term is uniformly bounded from below by some constant $C_e > 0$ depending on the uniform bounds on the solution f .

The induction formula (4.5) defining a_n yields

$$a_{n+1} \geq \text{cst } C_e \Delta_{n+1} a_n^2 \delta_n^{\gamma+N} \xi_n^{(N/2-1)}$$

and thus

$$a_{n+1} \geq \text{cst } C_e a_n^2 \left[2^{(N+\gamma)/2} \xi^{(N/2-1)} \beta \right]^n.$$

Then if we denote

$$\lambda = 2^{(N+\gamma)/2} \xi^{(N/2-1)} \beta$$

a similar computation as in the proof of Proposition 3.2 gives

$$a_n \geq (\text{cst } C_e)^{2^n - 1} \lambda^{[(n-1)2^0 + (n-2)2^1 + \dots + 02^{n-1}]} a_0^{2^n} \geq (\text{cst } C_e \lambda a_0)^{2^n}$$

and thus $a_n \geq \alpha^{2^n}$ if one takes $\alpha \leq \text{cst } C_e \lambda a_0$ and the induction is proved. This concludes the proof. \square

5. APPLICATION TO THE EXISTING CAUCHY THEORIES

In this section we shall use Theorem 1.1 and Theorem 1.2 to study solutions which have been constructed by previous authors, by connecting these theorems to some existing results in the Cauchy theory of the Boltzmann equation.

First we give a theorem which summarizes the situation in the spatially homogeneous setting for cutoff potentials in cases where the collision kernel does not present a singularity for vanishing relative velocity (a case which is not so well understood and for which L^p estimates have not yet been derived).

Theorem 5.1. *Let $B = \Phi b$ be a collision kernel satisfying assumptions (1.1), with Φ satisfying assumption (1.2) with $\gamma \geq 0$ or (1.3), and b satisfying (1.4) with $\nu < 0$. Let f_0 be a nonnegative initial condition on \mathbb{R}_v^N with finite mass, energy. Then*

- (i) *there exists a unique solution $f(t, v)$ with constant mass and energy to the spatially homogeneous Boltzmann equation, defined for all times;*
- (ii) *if f_0 has finite entropy, then the entropy of the solution remains uniformly bounded and the solution satisfies*

$$\forall t > 0, \forall v \in \mathbb{R}^N, \quad f(t, v) \geq \rho(t) \frac{e^{-\frac{|v|^2}{2\theta(t)}}}{(2\pi\theta(t))^{N/2}}.$$

The constants $\rho(t)$, $\theta(t) > 0$ are explicit and depend on the mass, energy and entropy of f_0 ; they are uniform for $t \rightarrow +\infty$ but not necessarily for $t \rightarrow 0$.

Remark: Let us sketch briefly how it is possible to relax the assumption of the boundedness of the entropy of the initial datum in point (ii) in the case $\gamma > 0$ in dimension 3. Indeed Mischler and Wennberg [28, Lemma 2.1] proved in this case that

$$g = Q^+(Q^+(f, f), f)$$

is uniformly integrable, with constants depending on the L_2^1 norm of f . The bound on the entropy is only used in the obtaining of the upheaval point in Lemma 2.3, whose proof requires the uniform integrability of the function. But in the initialization step of

Proposition 3.2, it is possible, up some tricky computations, to obtain by iterating twice more the Duhamel representation

$$\forall v \in \mathbb{R}^N, |v| \leq R_0, \quad f(t, x+vt, v) \geq C_{T, R_0, B} Q^+ \left[Q^+ \left[g_0^{R_0}(x, \cdot), g_0^{R_0}(x, \cdot) \right], g_0^{R_0}(x, \cdot) \right](v)$$

where $g_0 = Q^+(Q^+(f_0, f_0), f_0)$. As g_0 is uniformly integrable (with explicit bounds) by the result of Mischler and Wennberg above, one can apply Lemma 2.3 to

$$Q^+ \left[Q^+ \left[g_0^{R_0}(x, \cdot), g_0^{R_0}(x, \cdot) \right], g_0^{R_0}(x, \cdot) \right](v)$$

to get the upheaval point and the rest of the proof is unchanged.

Proof of Theorem 5.1. Let us prove (i): In the case Φ satisfies assumption (1.2) with $\gamma > 0$, the existence and uniqueness in L^1_2 (for solutions with non-increasing energy) are proved in [28]. In the case $\gamma = 0$ or Φ satisfies assumption (1.3) with $\gamma \in (-N, 0)$, existence and uniqueness in L^1_2 can be deduced from Arkeryd [3]: in this case the collision operator is a bounded bilinear operator in L^1 , which implies the uniqueness, and the global existence is proved by the monotonicity argument from [3]. For (ii): In all these cases the mass and energy are conserved. By the H theorem, if the entropy of the initial datum is bounded, then it remains bounded uniformly for all times. Thus the solution satisfies (1.6) and one can apply Theorem 1.1 and concludes the proof. \square

Now we give a theorem for non-cutoff mollified hard potentials collision kernels, using a recent result of Desvillettes and Wennberg [13]. Here $\mathcal{S}(\mathbb{R}_v^N)$ denotes the Schwartz space of the functions with all derivatives bounded and decreasing faster at infinity than any inverse of polynomial.

Theorem 5.2. *Let $B = \Phi b$ be a collision kernel satisfying assumptions (1.1), with Φ satisfying assumption (1.3) with $\gamma > 0$ and C^∞ , and b satisfying (1.4) with $\nu \in (0, 2)$. Let f_0 be a nonnegative initial condition on \mathbb{R}_v^N with finite mass, energy and entropy. Then*

- (i) *there exists a solution f to the spatially homogeneous Boltzmann equation with constant mass and energy and uniformly bounded entropy, defined for all times and belonging to $L^\infty([t_0, +\infty), \mathcal{S}(\mathbb{R}_v^N))$ for any $t_0 > 0$;*
- (ii) *this solution satisfies*

$$\forall t > 0, \forall v \in \mathbb{R}^N, \quad f(t, v) \geq C_1(t) e^{-C_2(t)|v|^K}$$

for any exponent K such that

$$K > 2 \frac{\log \left(2 + \frac{2\nu}{2-\nu} \right)}{\log 2}.$$

The constants $C_1(t), C_2(t) > 0$ are explicit and depend on the mass, energy, entropy of f_0 and K ; they are uniform for $t \rightarrow +\infty$ but not necessarily for $t \rightarrow 0$.

Proof of Theorem 5.2. First let us prove (i): Our assumptions on B imply the assumptions [13, Assumption 2] on the collision kernel B , namely $B = \Phi b$ with Φ a smooth and strictly positive function such that $\Phi(z) \sim_{|z| \rightarrow +\infty} |z|^\gamma$ with $\gamma \in (0, 1]$, and b such that $b(\cos \theta) \sim_{\theta \rightarrow 0} \text{cst } \theta^{-(N-1)-\nu}$ with $\nu > 0$. Concerning the initial datum our assumptions are exactly those of [13, Assumption 1]. So we can apply [13, Theorem 1] to prove the existence of a solution, lying in $L^\infty([t_0, +\infty), \mathcal{S}(\mathbb{R}_v^N))$ for any $t_0 > 0$. For (ii): The explicit bound $L^\infty([t_0, +\infty), \mathcal{S}(\mathbb{R}_v^N))$ for any $t_0 > 0$ immediately implies the uniform bounds (1.6) and (1.8). Thus one can apply Theorem 1.2 to obtain the lower bound for $t \geq t_0 + \tau$. As t_0 and τ are arbitrarily small this concludes the proof. \square

For spatially inhomogeneous solutions we can apply our results to the solutions near the equilibrium in a torus constructed by Ukai (see [33, 34] and [8, Section 7.6]) for hard spheres and Guo [21] for soft potentials. For the sake of clarity, we do not explicit in full details the functional settings in which these solutions are constructed and refer to the above-mentioned references for more precise definitions.

Theorem 5.3. *Let $B = \Phi b$ be a collision kernel satisfying assumptions (1.1), with*

- a- Φ satisfying assumption (1.2) with $\gamma = 1$ and $b = 1$ (solutions of Ukai) or
- b- Φ satisfying assumption (1.2) with $\gamma < 0$ and b satisfying (1.4) with $\nu < 0$ (solutions of Guo).

Let $f_0 = M + M^{1/2}h_0$ (M is the global Maxwellian equilibrium) be a nonnegative initial condition on $\mathbb{T}_x^N \times \mathbb{R}_v^N$ such that

$$\|h_0\|_{H^{s,q}}^2 := \sum_{|i|+|j|\leq s} \|h_0 \langle v \rangle^q\|_{L^2(\mathbb{T}^N \times \mathbb{R}^N)}^2 \leq \epsilon_0$$

with $s, q, \epsilon_0 > 0$. Then

- (i) for any $s', q' > 0$, if s, q are large enough and ϵ_0 is small enough, there exists a unique solution f to the full Boltzmann equation in $H^{s',q'}$, defined for all times, with uniform bound in $H^{s',q'}$ depending on ϵ_0 ;
- (ii) this solution satisfies

$$\forall t > 0, \forall x \in \mathbb{T}^N, \forall v \in \mathbb{R}^N, \quad f(t, x, v) \geq \rho(t) \frac{e^{-\frac{|v|^2}{2\theta(t)}}}{(2\pi\theta(t))^{N/2}}.$$

The constants $\rho(t), \theta(t) > 0$ depend on ϵ_0 ; they are uniform for $t \rightarrow +\infty$ but not necessarily for $t \rightarrow 0$.

Remarks: 1. Most probably the solutions of Ukai could extend to any cutoff hard potentials, even if they were constructed for hard spheres. Anyhow the method of Guo would probably recover the result for any cutoff hard potentials as well.

2. The proof of Ukai uses the spectral gap of the linearized collision operator for hard spheres, which was known to exist since Grad [20]. This spectral gap was obtained by non-constructive method (essentially the Weyl's Theorem about compact perturbation of

the essential spectrum). However explicit estimates on this spectral gap were recently obtained in [5], which is a step forward into a constructive theory. Nevertheless at now the proofs of Ukai (and Guo for soft potentials) still do not provide constructive bounds.

3. One can apply the result of convergence to equilibrium of Desvillettes and Villani [12] to the solutions of Theorem 5.3, which do satisfy every assumption of [12, Theorem 2]. Thus they converges almost exponentially to equilibrium, i.e

$$\|f_t - M\|_{L^1_{x,v}} \leq C_\alpha t^{-1/\alpha}$$

where α can be taken as big as wanted when s and q are large enough, and the constant C_α is explicit according to the uniform regularity bounds on f and the constants in the lower bound. For the solutions of Ukai in the hard spheres case, this result is weaker than the exponential convergence to equilibrium already proved by Ukai, but the convergence to equilibrium was unknown for the solutions of Guo in the case of soft potentials.

4. Let us explain how to skip the “upheaval step” of the proof for solutions near the equilibrium. Indeed in the case of perturbative solutions, which are L^∞ close to a global Maxwellian distribution, Lemma 2.3 can be bypassed by a more direct argument: up to reduce the neighborhood of the Maxwellian distribution for the existence theory (i.e. reducing ϵ_0), the uniform L^∞ control of smallness on h yields

$$\forall t \in \mathbb{R}_+, \forall x \in \mathbb{T}^N, \forall v \in \mathbb{R}^N, \quad f(t, x, v) \geq \eta_0 \mathbf{1}_{B(0, \delta_0)}$$

for some $\eta_0 > 0$ and $\delta_0 > 0$.

Proof of Theorem 5.3. One can check easily that for s and q large enough and ϵ_0 small enough in the assumptions on the initial data, f_0 satisfies the assumptions of [8, Theorem 7.6.2] in the case of Ukai’s solutions, and the assumptions of [21, Theorem 1] for Guo’s solutions. Then for s large enough, the uniform smoothness estimates on the solution imply in both cases a bound on $\|h_t\|_{L^\infty_{x,v}}$, uniform for all times, and going to 0 as $\epsilon_0 \rightarrow 0$. Thus if one take ϵ_0 small enough such that

$$\left(\sup_{t \geq 0} \|h_t\|_{L^\infty_{x,v}} \right) \int_{\mathbb{R}_v^N} \sqrt{M(v)} dv \leq \frac{1}{2} \int_{\mathbb{R}_v^N} M(v) dv$$

one immediately get

$$\varrho_f \geq \frac{1}{2} \int_{\mathbb{R}_v^N} M(v) dv > 0$$

for all times. The uniform upper bounds on the local energy and local entropy (and local L^p bound) follow from the uniform regularity bounds on the solution. Thus the solution satisfies (1.6) and (1.7) and one can apply Theorem 1.1 and conclude the proof. \square

Finally, let us say a few words about other Cauchy theories.

In the spatially inhomogeneous setting, one could apply Theorem 1.1 to solutions for small time constructed in [23] (in the cutoff case). We did not detail this application since we were more interested with global solutions.

One could also apply Theorem 1.1 to the global weakly inhomogeneous solutions (for cutoff hard potentials) constructed by Arkeryd, Esposito and Pulvirenti in [4], which would give a Maxwellian lower bound on these solutions (uniform as $t \rightarrow +\infty$). Note that the uniform bounds on the solution obtained in [4] do not seem to be constructive. As a consequence the Maxwellian lower bound given by Theorem 1.1 would not have constructive constants.

Concerning the global solutions in the whole space \mathbb{R}^N near the vacuum constructed by Kaniel, Illner and Shinbrot (cf. [22, 27, 19] or [8, Section 5.2]), a lower bound on the solution $f(t, x, v)$ cannot be uniform in space since $f(t, \cdot, \cdot)$ is integrable on $\mathbb{R}_x^N \times \mathbb{R}_v^N$, and it cannot be uniform as t goes to infinity since the solution goes to 0 as t goes to infinity for every (x, v) such that $v \neq 0$ (see [8, Theorem 5.2.2]). Our method could not apply, and is more adapted to evolution problems in bounded domains. We note that for these solutions in the whole space, in some cases a bound from below on the solutions by a “travelling Maxwellian”

$$\forall t \geq 0, \forall x \in \mathbb{R}^N, \forall v \in \mathbb{R}^N, \quad f(t, x, v) \geq C(t) e^{-\beta|x-tv|^2} e^{-\alpha|v|^2}$$

(where $\alpha > 0$ and $\beta > 0$ are absolute constants, and $C(t) > 0$ is a constant depending on time) can replace our method to provide a lower bound (see for instance [19], and also, in the same spirit [26]).

Acknowledgment: Support by the European network HYKE, funded by the EC as contract HPRN-CT-2002-00282, is acknowledged.

REFERENCES

- [1] ALEXANDRE, R. AND DESVILLETES, L. AND VILLANI, C. AND WENNBORG, B., On the rate of entropy production for the Boltzmann equation. *Arch. Ration. Mech. Anal.* 152, 4 (2000), 327–355.
- [2] ALEXANDRE, R. AND VILLANI, C., On the Boltzmann equation for long-range interactions. *Comm. Pure Appl. Math.* 55, 1 (2002), 30–70.
- [3] ARKERYD, L., On the Boltzmann Equation. *Arch. Ration. Mech. Anal.* 45 (1972), 1–34.
- [4] ARKERYD, L. AND ESPOSITO, R. AND PULVIRENTI, M., The Boltzmann equation for weakly inhomogeneous data. *Comm. Math. Phys.* 111, 3 (1987), 393–407.
- [5] BARANGER, C. AND MOUHOT, C., Explicit spectral gap estimates for the linearized Boltzmann and Landau operators with hard potentials. To appear in *Rev. Mat. Iberoamericana*.
- [6] CARLEMAN, T., Sur la théorie de l'équation intégrodifférentielle de Boltzmann. *Acta Math.* 60 (1932).
- [7] CARLEMAN, T., *Problèmes mathématiques dans la théorie cinétique des gaz*. Publ. Sci. Inst. Mittag-Leffler. 2. Almqvist & Wiksells Boktryckeri Ab, Uppsala (1957).
- [8] CERCIGNANI, CARLO AND ILLNER, REINHARD AND PULVIRENTI, MARIO, *The mathematical theory of dilute gases*, vol. 106 of *Applied Mathematical Sciences*. Springer-Verlag, New York, 1994.
- [9] DESVILLETES, L. AND VILLANI, C., On the spatially homogeneous Landau equation for hard potentials. I. Existence, uniqueness and smoothness. *Comm. Partial Differential Equations* 25, 1–2 (2000), 179–259.
- [10] DESVILLETES, L. AND VILLANI, C., On the spatially homogeneous Landau equation for hard potentials. II. H -theorem and applications. *Comm. Partial Differential Equations* 25, 1–2 (2000), 261–298.
- [11] DESVILLETES, L. AND VILLANI, C., On the trend to global equilibrium in spatially inhomogeneous entropy-dissipating systems: the linear Fokker-Planck equation. *Comm. Pure Appl. Math.* 54, 1 (2001), 1–42.

- [12] DESVILLETES, L. AND VILLANI, C., On the trend to global equilibrium in spatially inhomogeneous entropy-dissipating systems: the Boltzmann equation. *Invent. Math.* 105, (2004).
- [13] DESVILLETES, L. AND WENBERG, B., Smoothness of the solution of the spatially homogeneous Boltzmann equation without cutoff. *Comm. Partial Differential Equations* 29, 1–2 (2004), 133–155.
- [14] DIPERNA, R. J. AND LIONS, P.-L., On the Cauchy problem for Boltzmann equations: global existence and weak stability. *Ann. of Math. (2)* 130, 2 (1989), 321–366.
- [15] FOURNIER, N., Strict positivity of a solution to a one-dimensional Kac equation without cutoff. *J. Statist. Phys.* 99, 3–4 (2000), 725–749.
- [16] FOURNIER, N., Strict positivity of the solution to a 2-dimensional spatially homogeneous Boltzmann equation without cutoff. *Ann. Inst. H. Poincaré Probab. Statist.* 37, 4 (2001), 481–502.
- [17] FOURNIER, N., Strict positivity of the density for simple jump processes using the tools of support theorems. Application to the Kac equation without cutoff. *Ann. Probab.* 30, 1 (2002), 135–170.
- [18] GAMBA, I. AND PANFEROV, V. AND VILLANI, C., Upper Maxwellian bounds for the spatially homogeneous Boltzmann equation. Work in progress.
- [19] GOUDON, T., Generalized invariant sets for the Boltzmann equation. *Math. Models Methods Appl. Sci.* 7, 4 (1997), 457–476.
- [20] GRAD, H., Principles of the Kinetic Theory of Gases. In *Flügge's Handbuch des Physik*, vol. XII. Springer-Verlag, 1958, pp. 205–294.
- [21] GUO, Y., Classical solutions to the Boltzmann equation for molecules with an angular cutoff. *Arch. Ration. Mech. Anal.* 169, 4 (2003), 305–353.
- [22] ILLNER, R. AND SHINBROT, M., The Boltzmann equation: global existence for a rare gas in an infinite vacuum. *Comm. Math. Phys.* 95, 2 (1984), 217–226.
- [23] KANIEL, S. AND SHINBROT, M., The Boltzmann equation. I. Uniqueness and local existence. *Comm. Math. Phys.* 58, 1 (1978), 65–84.
- [24] LIONS, P.-L., Compactness in Boltzmann's equation via Fourier integral operators and applications. I, II. *J. Math. Kyoto Univ.* 34, 2 (1994), 391–427, 429–461.
- [25] LIONS, P.-L., Compactness in Boltzmann's equation via Fourier integral operators and applications. III. *J. Math. Kyoto Univ.* 34, 3 (1994), 539–584.
- [26] LU, X., Spatial decay solutions of the Boltzmann equation: converse properties of long time limiting behavior. *SIAM J. Math. Anal.* 30, 5 (1999), 1151–1174.
- [27] MISCHLER, S. AND PERTHAME, B., Boltzmann equation with infinite energy: renormalized solutions and distributional solutions for small initial data and initial data close to a Maxwellian. *SIAM J. Math. Anal.* 28, 5 (1997), 1015–1027.
- [28] MISCHLER, S. AND WENBERG, B., On the spatially homogeneous Boltzmann equation. *Ann. Inst. H. Poincaré Anal. Non Linéaire* 16, 4 (1999), 467–501.
- [29] MOUHOT, C. AND VILLANI, C., Regularity theory for the spatially homogeneous Boltzmann equation with cut-off. *Arch. Rational Mech. Anal.* 173, 2 (2004), 169–212.
- [30] PULVIRENTI, A. AND WENBERG, B., A Maxwellian lower bound for solutions to the Boltzmann equation. *Comm. Math. Phys.* 183, 1 (1997), 145–160.
- [31] TOSCANI, G. AND VILLANI, C., Sharp entropy dissipation bounds and explicit rate of trend to equilibrium for the spatially homogeneous Boltzmann equation. *Comm. Math. Phys.* 203, 3 (1999), 667–706.
- [32] TOSCANI, G. AND VILLANI, C., On the trend to equilibrium for some dissipative systems with slowly increasing a priori bounds. *J. Statist. Phys.* 98, 5–6 (2000), 1279–1309.
- [33] UKAI, S., On the existence of global solutions of mixed problem for non-linear Boltzmann equation. *Proc. Japan Acad.* 50 (1974), 179–184.
- [34] UKAI, S., Les solutions globales de l'équation de Boltzmann dans l'espace tout entier et dans le demi-espace. *C. R. Acad. Sci. Paris Sér. A-B* 282, 6 (1976), Ai, A317–A320.
- [35] VILLANI, C., On a new class of weak solutions to the spatially homogeneous Boltzmann and Landau equations. *Arch. Rational Mech. Anal.* 143, 3 (1998), 273–307.

- [36] VILLANI, C., A review of mathematical topics in kinetic theory. *Handbook of mathematical fluid dynamics*, vol. I, 71–305. North-Holland, Amsterdam, 2002.
- [37] VILLANI, C., Cercignani’s conjecture is sometimes true and always almost true. *Comm. Math. Phys.* 234, 3 (2003), 455–490.

C. MOUHOT

UMPA, ÉNS LYON
46 ALLÉE D’ITALIE
69364 LYON CEDEX 07
FRANCE

E-MAIL: cmouhot@umpa.ens-lyon.fr