

# THEORETICAL STUDY AND EXPERIMENTAL RESULT OF THE RF COUPLER PROTOTYPES OF SPIRAL2

Y. Gómez Martínez, D. Bondoux, JM. Carretta, JM. De Conto, M. Fruneau, A. Garrigue, D. Marchand, R. Micoud, E. Vernay, F. Vezzu, LPSC (CNRS/IN2P3-UJF-INPG), Grenoble, France  
M. Di Giacomo, GANIL, Caen, France  
P. Balleyguier, CEA/DAM, Bruyères-le-Châtel, France

## Abstract

Spiral2 is a 40 MeV-5mA deuterons and a 14.5 MeV/u-1mA heavy ions superconducting linac under construction at GANIL. The RF couplers have to provide 12 kW CW power to the cavities at 88 MHz for an accelerating field of 6.5 MV/m. Two solutions corresponding to two different technologies have been designed and two prototypes have been built. We present the technical proposals and issues as well as the results (manufacturing, test at low and high power, multipacting...) leading to the final choice.

## INTRODUCTION

The LINAC section of the Spiral2 accelerator will use two different types of  $\lambda/4$  superconducting cavities (for  $\beta = 0.07$  and  $\beta = 0.12$  [1]). Each cavity will be fed via one coaxial RF coupler.

The coupling will be electrical, with an antenna located in the bottom of the cavity. A magnetic coupling loop has not been chosen due to technical difficulties to place such a device on top of the cavity. The couplers will not be adjustable so the RF system will have to manage some reflected power.

The coupler has only one ceramic window. Two types of windows have been studied: a disc-shape window (6mm thickness) and a cylindrical one (34mm length) and two prototypes have been built.

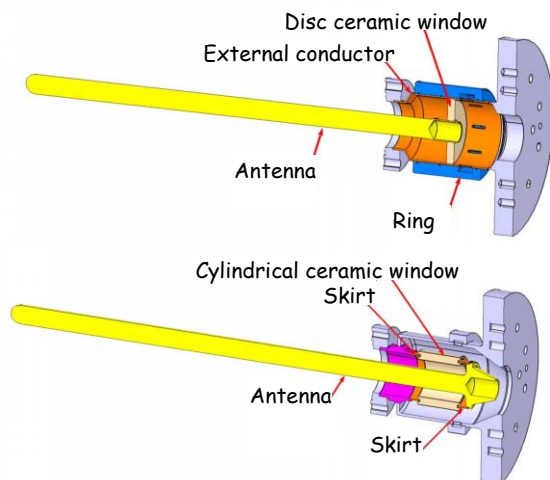

Figure 1: The two kinds of couplers with the disc-shape (up) and the cylindrical (down) ceramics.

The transition from ambient temperature to the Helium temperature (4.2 K) is considered in terms of static and

dynamic heat transfer. Hence, multiple iterations between RF design (HFSS) and thermal calculations have been performed.

## MECHANICAL DESIGN

The coupler is mounted standing upright at the bottom of the cavity.

One internal bellows is used for the coupler itself to compensate for misalignments and differential thermal expansions. A second external bellows, connected to the vacuum, is used to compensate for atmospheric pressure and thus prevent strains on the cavity.

The connection to the outside is made from the internal 1"5/8 EIA line to a 1"5/8 EIA - 3"1/8EIA transition. The external feeder to the amplifier is a 3"1/8EIA coaxial line.

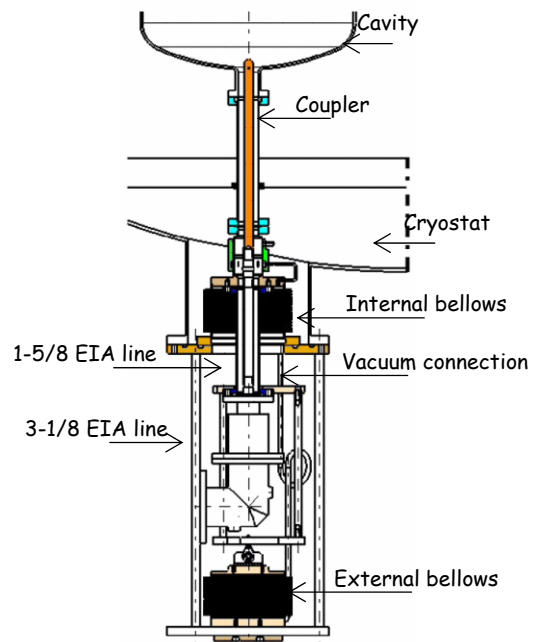

Figure 2: Coupling to  $\beta=0.12$  cavity developed at IPN Orsay (CNRS/IN2P3).

All the coupler components are brazed. The internal antenna is made of massive copper. The external part is made of copper plated ( $20 \mu\text{m} \pm 20\%$ ) stainless steel. An air cooling of the window is made to keep the ceramic window at ambient temperature and to prevent condensation.



Figure 3: Prototype with disc window (left) and cylindrical window (right).

## SIMULATIONS

### RF Simulations

The 3-D HFSS code has been used. The antenna part is a 1"5/8 line. The coupler diameter is optimized in the window region to minimize the reflected power. For the cylindrical window we get  $S_{11} = -32$  dB, and  $S_{11} = -50$  dB for the disc.

For 20 kW RF power, the maximum value of electric field in the window is about  $2.10^5$  V/m for the disc window and  $5.10^4$  V/m for the cylindrical one. So, for both technologies, moderate electric fields and a good RF transmission can be achieved at 88 MHz.

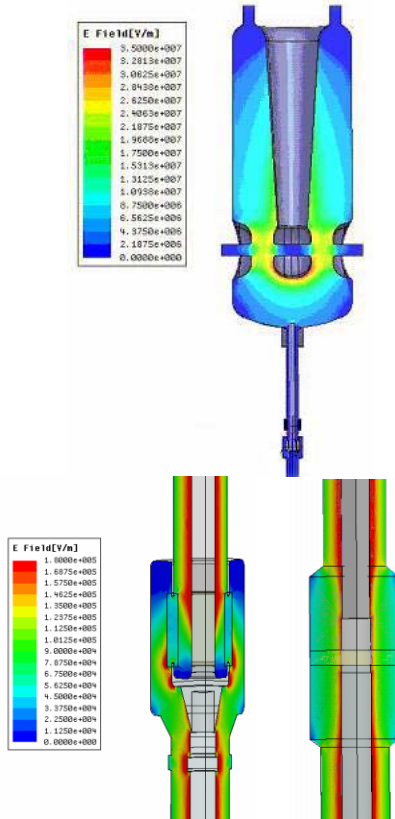

Figure 4: Electric field in the cavity coupling with the coupler (up), near the cylindrical window (down left) and near the disc window (down right) obtained from HFSS (antenna tip penetration: 13 mm, RF power: 20 kW).

The external quality factor ( $Q_{ext}$ ) at nominal current (5 mA deuterons) varies from  $1.3 \cdot 10^6$  and  $2.4 \cdot 10^5$  depending on the cavity location. As said before, the antenna penetration is not adjustable and 10 mm has been chosen in order to minimize the RF mismatch in nominal conditions. The external part of the RF system will be designed to handle the reflected power.

### Mechanical Stress Simulations

A random vibration study has been made to evaluate mechanical stresses induced by the transport, although the first vibration frequency of the coupler (65 Hz) is above the range of maximal acceleration of transport (from 0 to 40 Hz).

### Thermal Simulations

The finite element SAMCEF code is used for thermal calculations. The dissipated power used in thermal simulation is obtained from the three dimensional RF simulations.

During the simulation, the thermal conductivity and electrical resistivity of materials (copper and steel) vary according to the temperature.

The study is made for different residual resistance ratios (RRR) of copper: 10, 30 and 100.

For both technologies, numerical simulations provide similar results. The maximum temperatures at the tip of the antenna and the thermal loads at « cold » links are acceptable.

Table 1: Temperatures (K) of disc window. Copper RRR30.

RF power	Antenna tip temperature	Maximal ceramics temperature
At 0 kW	288 K	288 K
At 20 kW	335.3 K	314.5 K

Table 2: Thermal loads (watts) of disc window. Copper RRR30.

RF power	Thermal load at 4.2K link	Thermal load at the cavity (estimation)
At 0 kW	1 W	0.1 W
At 20 kW	1.1 W	0.2 W

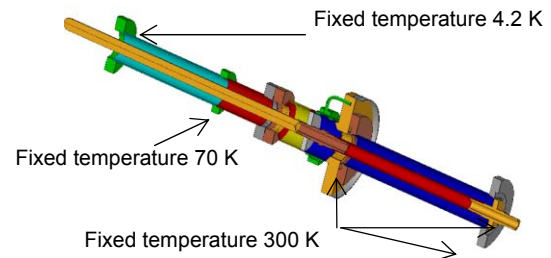

Figure 5: Thermal boundaries conditions for the disc window coupler model.

## LOW POWER TEST

The reflection coefficient  $S_{11}$  has been measured for both couplers. The theoretical value (-50 dB, disc window) is anyway very optimistic. For both couplers, a value between -32 and -35 dB is obtained, which is acceptable.

Table 3: Comparison of theoretical and measured  $S_{11}$

Type of window	$S_{11}$ measured	$S_{11}$ HFSS
Disc window	-32 dB	-50 dB
Cylindrical window	-35 dB	-32 dB

## HIGH POWER TEST

### Amplifier

A 40 kW tube amplifier is used. The final stage uses a EIMAC triode while the driver is a solid state 3 kW amplifier. A proper adjustment of the transmission line length between the load and the amplifier is needed to be able to handle 100% reflected power at 10 kW.

### Test Bench

In classical test benches, a coupler is connected to a waveguide resonator with an output coupler connected to a 50 Ohm load. At 88 MHz, the size of the cavity is prohibitive and a different solution has been chosen. In a first configuration, a coupler is tested in a stand-alone configuration with an open or shorten termination, in a full stationary wave mode. In a second configuration, two couplers are mounted in a push-pull configuration and tested simultaneously in a traveling wave mode. The same bench is used for the two configurations.

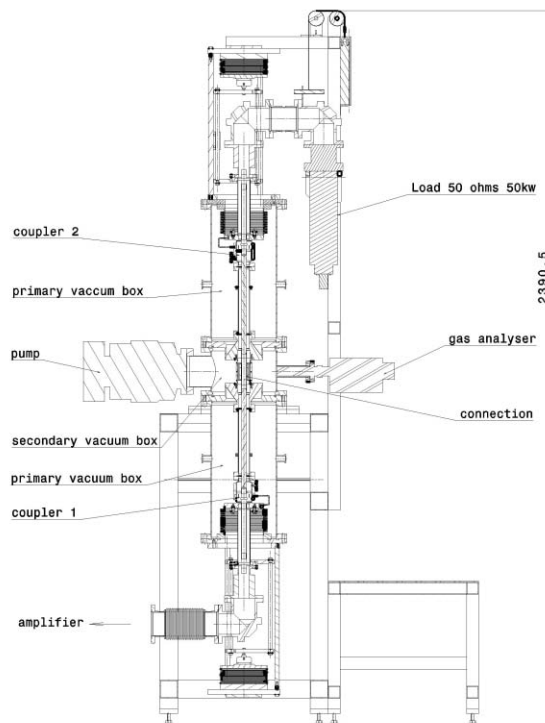

Figure 6: Traveling wave test bench.

A directional coupler is used to measure the incident and reflected power.

The vacuum system provides a  $3.4 \cdot 10^{-8}$  mbar pressure comparable to the pressure foreseen in the accelerator.

Multipactor is carefully controlled by a continuous pressure monitoring and by an electron pick-up. An interlock system on the vacuum system guarantees any damage on the coupler.

### Tests

The Spiral 2 maximum power ( for an accelerating field of 6.5 MV/m) transmitted to the beam is 12 kW CW. Tests in standing wave (with an open circuit and a short circuit) are made up to 10 kW CW and the test in traveling wave is made close to 40kW.

The conditioning time, with a slow power increase, was 196 hours for the disc window (164h in standing wave mode and 32h in traveling wave) and 117 hours for the cylindrical window (85h in standing wave mode and 32h in traveling wave).

In order to reduce these times, a baking is foreseen for the next couplers.

### Multipacting

Analytical studies have shown that multipactor may occur mainly at low power, below 100 W. Some pressure increase has been observed in the 0-300W range and not for a higher power. This phenomenon is then not an issue, but a TiN deposition will be made anyway on the ceramics.

### Clean Room

The use of the coupler in superconducting cavities requires very clean surfaces. A clean room has been constructed with a system of high purity water (18 M $\Omega$ ).

## CONCLUSIONS

The test results are very good for the two designs. The technologies appear to be comparables, but the disc shape solution is easiest in term of vacuum control and electron pick up set up. This solution has been chosen. The goal is to start now the production of 40 couplers in 2007 and the completion of the production foreseen in 2009.

## ACKNOWLEDGEMENTS

Many thanks to T.Junquera, S.Bousson, H.Saugnac (IPNO, IN2P3), T.Garvey, P.Leperqc (LAL, IN2P3), P.Bosland (CEA Saclay) for their very kind help and advices.

## REFERENCES

- [1] G. Olry et al., "Status of the Beta 0.12 superconducting cryomodule development for the Spiral II project", this conference.