

# ITERATIVE CHANNEL ESTIMATION FOR ORTHOGONAL STBC MC-CDMA SYSTEMS OVER REALISTIC HIGH-MOBILITY MIMO CHANNELS

Fabrice Portier<sup>1</sup>, Stephan Sand<sup>2</sup>, and Jean-François Hélar<sup>1</sup>

<sup>1</sup> Institute of Electronics and Telecommunications in Rennes

INSA, 20 Ave. des Buttes de Coësmes, 35043 Rennes Cedex, France – fabrice.portier@insa-rennes.fr

<sup>2</sup> German Aerospace Center, Institute of Communications and Navigation  
Oberpfaffenhofen, 82234 Wessling, Germany – stephan.sand@dlr.de

## ABSTRACT

This paper considers a downlink multiple-input multiple-output (MIMO) multi-carrier code division multiple access (MC-CDMA) system with pilot aided channel estimation (PACE) and iterative channel estimation (ICE) in the receiver. Exploiting orthogonal space-time block coding (STBC), we investigate ICE schemes as a simple extension of PACE using estimated data chips as additional pilots. Due to the superposition of different users' spread data signals, zero-valued chips can occur after spreading, which can cause noise enhancement when using data estimates as reference signals in ICE. Hence, we propose MIMO channel estimation methods to overcome the above problem. Simulations with a realistic outdoor MIMO channel model, over a wide range of data rates and speeds, show that ICE can outperform PACE at the cost of increased complexity.

## I. INTRODUCTION

Orthogonal frequency division multiplexing (OFDM) [1] is a suitable technique for broadband transmission over multipath fading radio channels achieving high data rates. In addition to the coherent OFDM modulation, spreading in frequency direction is introduced for multi-carrier code division multiple access (MC-CDMA). MC-CDMA is a promising candidate for the downlink of future mobile communication systems and has been implemented in experimental systems by NTT DoCoMo and the European IST projects MATRICE [2] and 4MORE [3]. High data rate MC-CDMA systems can additionally employ multiple-input and multiple-output (MIMO) techniques, e.g., the Alamouti space-time block code (STBC) [4].

Coherent STBC OFDM systems require channel state information (CSI) at the receiver. Thus, pilot symbols are often periodically inserted into the transmitted signal to support channel estimation (CE). First, CE is performed using the least-squares (LS) algorithm on pilots only; then we interpolate these localized estimates (LEs) on the time-frequency grid, exploiting correlations of the time- and frequency-selective radio channel. In case of pilot aided channel estimation (PACE), the interpolation is achieved by cascading two one-dimensional (1D) finite-impulse response (FIR) filters whose coefficients are based on the minimum mean square error (MMSE) criterion [1].

To further improve PACE, [5, 6, 7] use previously decided data symbols as reference in iterative channel estimation (ICE). In [6], the authors propose an ICE algorithm for OFDM that

feeds back information from the output of the channel decoder to the estimation stage to reduce decision feedback errors. Since the CE gets additional information from the estimated data symbols, ICE achieves a further reduction of the bit error rate (BER).

Previously, we proposed several MIMO MC-CDMA systems and studied the effect of CE errors on these 4<sup>th</sup> Generation (4G) schemes [8]. In [7], we described SISO ICE methods. In this paper, we extend the idea of ICE to a MIMO MC-CDMA system with Walsh-Hadamard (WH) spreading codes, and propose modified LS (MLS) methods to solve the problem of zero-valued chips after spreading. At the transmitter, we employ orthogonal STBCs, such as the Alamouti scheme. We compare the performance of PACE and ICE for a downlink MIMO MC-CDMA system with two transmit and two receive antennas. Simulation results are obtained for a realistic outdoor MIMO channel based on the 3GPP/SCM MIMO channel model [9, 10].

In this paper, the superscripts  $T$  and  $H$  denote the transpose and Hermitian of a matrix respectively.

## II. SYSTEM MODEL

Figure 1 represents the block diagram of the downlink MIMO MC-CDMA system with ICE. At the transmitter, a binary signal of a single user out of  $K$  active users is encoded by a channel coder and interleaved by a random bit interleaver. The bits  $b_k$  (Figure 1(b)) are modulated and serial-to-parallel converted to  $M$  data symbols per user in an OFDM symbol. After spreading with a WH sequence of length  $L$  ( $L \geq K$ ), the spread signals are combined and serial-to-parallel converted to form the data symbol vector  $\underline{s}_l = [S_{1,l}, \dots, S_{N_c,l}]^T$  ( $\{l\} \in \mathcal{D}$ ). Here,  $N_c = M \cdot L$  denotes the number of subcarriers per OFDM symbol,  $l$  the OFDM symbol number, and  $\mathcal{D}$  the set of data symbol positions in a frame. Next,  $\underline{s}_l$  (Figure 1(a)) is space-time coded and each  $\underline{s}_l^m$  ( $\{l\} \in \mathcal{D}^m$ ,  $m = 1, \dots, N_{TX}$ ) is multiplexed together with pilot symbols  $\underline{s}_{l'}^m$  ( $\{l'\} \in \mathcal{P}$ ,  $m = 1, \dots, N_{TX}$ ).  $\mathcal{P}$  denotes the set of all pilot symbol positions in a frame.  $N_{TX}$  subsequent full OFDM pilot symbols are inserted at the beginning, in the middle and at the end of each frame (Figure 1(c)). For each transmit antenna, a unique WH spreading code is applied to the pilot symbols in time direction. If the time variation of the channel is small enough over the consecutively spread pilots, the pilot symbols for each transmit antenna can be despread at the receiver to obtain LEs of the CSI. Here, we assume that the pilot and data sets are disjoint, i.e.,  $\mathcal{P} \cap \mathcal{D} = \emptyset$ . The resulting  $N_{TX}$  frames with

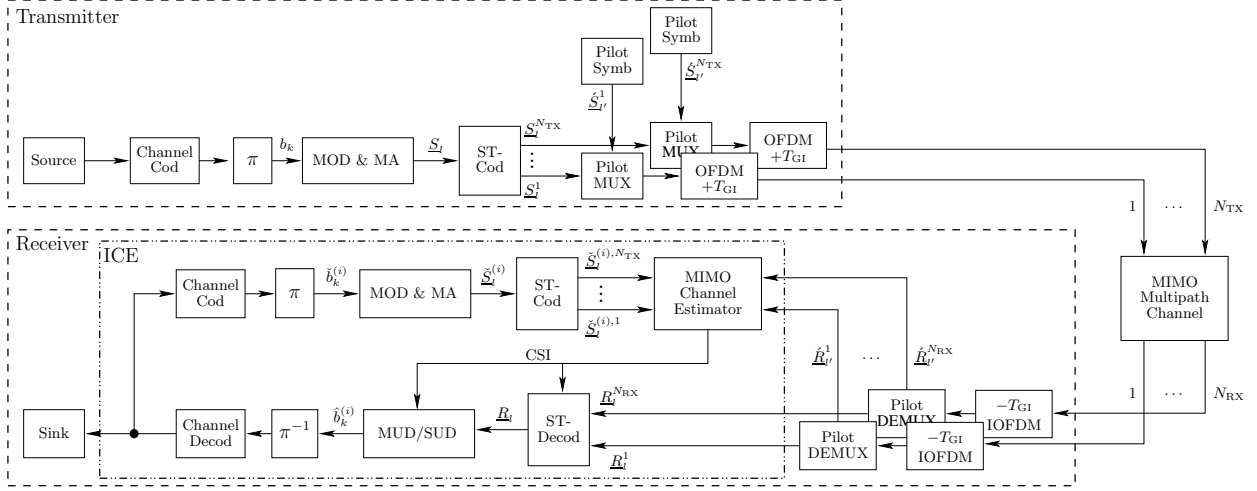

(a) MIMO MC-CDMA: transmitter and receiver with ICE

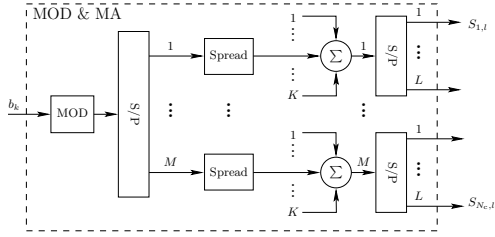

(b) Modulation and multiple access: MOD & MA



S = synchronization, G = guard, P = pilot, and D = data OFDM symbol

(c) Downlink frame

Figure 1: Downlink MIMO MC-CDMA system with ICE

$N_c$  subcarriers and  $N_s$  OFDM symbols are OFDM modulated and cyclically extended by the guard interval (GI) before they are transmitted over a time-variant MIMO multipath channel, which adds white Gaussian noise.

The received symbols are shortened by the GI and OFDM demodulated for each of the  $N_{RX}$  receive antennas. Then, the received pilot symbols  $\hat{R}_{l'}^p$  ( $\{l'\} \in \mathcal{P}$ ,  $p = 1, \dots, N_{RX}$ ) are separated from the received data symbols  $\hat{R}_l^p$  ( $\{l\} \in \mathcal{D}$ ), and fed into the CE. In the initial iteration ( $i = 0$ ), the CE only uses pilot symbols to estimate the CSI. After demultiplexing and space-time decoding the received data symbols  $\hat{R}_l^p$  ( $\{l\} \in \mathcal{D}$ ), either one multi-user detector (MUD) or  $K$  single-user detector (SUD) blocks return soft-coded bits  $\hat{b}_k^{(i)}$  of all users [7]. Subsequently, the bits are used to reconstruct the transmit signal  $\hat{\tilde{S}}_l^{(i),m}$  ( $m = 1, \dots, N_{TX}$ ), in ICE (Figure 1(a)).

In the  $i^{th}$  iteration of ICE ( $i > 0$ ), the CE exploits the received pilot symbols  $\hat{R}_{l'}^p$  ( $\{l'\} \in \mathcal{P}$ ), the received data symbols  $\hat{R}_l^p$  ( $\{l\} \in \mathcal{D}$ ), and the reconstructed transmit signal  $\hat{\tilde{S}}_l^{(i),m}$  ( $\{l\} \in \mathcal{D}$ ,  $m = 1, \dots, N_{TX}$ ) to improve the accuracy of the estimates. The newly obtained CSI estimates are fed back to the space-time decoder and the MUD/SUD block to improve the estimates of the transmitted bits. The next section describes PACE and ICE and investigates how ICE needs to be adapted for a downlink MIMO MC-CDMA system using orthogonal STBCs.

### III. CHANNEL ESTIMATION

#### A. Pilot Aided Channel Estimation (PACE)

Since the pilot symbols for different antennas are transmitted on the same positions, we first need to compute LEs of the CSI for each pair of transmit and receive antenna. For notational convenience, we drop the subcarrier and symbol index.  $N_{TX}$  consecutive pilot symbols in time direction at each transmit antenna are then given by

$$\begin{bmatrix} \hat{S}_1^m \\ \vdots \\ \hat{S}_{N_{TX}}^m \end{bmatrix} = \underline{w}_m \cdot \hat{S}, \quad (1)$$

where  $\underline{w}_m$  is column  $m$  of the  $N_{TX} \times N_{TX}$  WH spreading matrix [1] and  $\hat{S}$  is a pilot symbol. Note that  $w_m^T w_p$  is one only for  $m = p$  and otherwise zero. The averaged LE  $\check{H}^{m,p}$  of the channel transfer function between transmit antenna  $m$  and receive antenna  $p$  of the pilot symbol block is obtained by the LS estimation in (2), i.e., we despreading the  $N_{TX}$  consecutively received pilot symbol  $\hat{R}_1^p, \dots, \hat{R}_{N_{TX}}^p$  with the WH spreading vector  $\underline{w}_m$ . Assuming that the channel is approximately constant for the length of  $\underline{w}_m$ , we verify (3) where  $Z^p$  denotes an equivalent additive white Gaussian noise component at receive antenna  $p$ .

$$\check{H}^{m,p} = \frac{1}{\hat{S}} \underline{w}_m^T \begin{bmatrix} \hat{R}_1^p \\ \vdots \\ \hat{R}_{N_{TX}}^p \end{bmatrix}. \quad (2)$$

$$\check{H}^{m,p} = H^{m,p} + \frac{1}{\check{S}} \omega_m^T Z^p. \quad (3)$$

The final estimates of the channel transfer function are obtained from the LEs  $\check{H}_{n',l'}^{m,p}$  by two-dimensional (2D) filtering:

$$\hat{H}_{n,l}^{m,p} = \sum_{\{n',l'\} \in \mathcal{T}_{n,l}} \omega_{n',l'} \check{H}_{n',l'}^{m,p}, \quad \forall \{n,l\} \in \mathcal{D}, \quad (4)$$

where  $\omega_{n',l'}$  is the 2D FIR filter. The subset  $\mathcal{T}_{n,l} \subseteq \mathcal{P}$  is the set of LEs  $\check{H}_{n',l'}^{m,p}$  used to obtain  $\hat{H}_{n,l}^{m,p}$ .

The optimum solution of (4) in the MSE sense is the 2D Wiener filter [1]. Assuming the delay and Doppler power spectral densities (PSDs) to be statistically independent, the 2D filter can be replaced by two cascaded 1D filters, one for filtering in frequency and one for filtering in time direction. Since in practice the channel statistics are not perfectly known at the receiver, the CE filters are designed robust using for example a uniform Doppler PSD ranging from  $-f_{\text{DFIR}}$  to  $f_{\text{DFIR}}$ . Note, the maximum Doppler frequency  $f_{D_{\text{max}}}$  of the channel can be different from  $f_{\text{DFIR}}$ . As the considered STBC detection only requires one channel estimate for 2 OFDM symbols, we only compute one final estimate in the middle of 2 symbols to reduce filtering complexity.

### B. Iterative Channel Estimation (ICE): LEs

We investigate ICE in detail for a MIMO MC-CDMA system. After reconstructing the transmitted signal from the estimated information bits, the estimated data symbols and the transmitted pilot symbols form the set  $\mathcal{P}_{\text{ICE}} = \mathcal{P} \cup \mathcal{D}$  of reference symbols known at the receiver. The set  $\mathcal{P}_{\text{ICE}}$  defines the complete frame of pilot and data symbols. When employing orthogonal STBC, we can exploit the orthogonality to compute  $\check{H}^{(i),m,p}$  at  $\mathcal{D}$ . In the case of the Alamouti scheme [4], (2) becomes for the data LEs

$$\begin{aligned} \begin{bmatrix} \check{H}^{(i),1,p} \\ \check{H}^{(i),2,p} \end{bmatrix} &= \frac{\sqrt{2}}{\mathcal{S}^{(i)2}} \begin{bmatrix} \check{S}_1^{(i)} & \check{S}_2^{(i)} \\ -(\check{S}_2^{(i)})^* & (\check{S}_1^{(i)})^* \end{bmatrix}^H \cdot \begin{bmatrix} R_1^p \\ R_2^p \end{bmatrix}, \quad (5) \\ \mathcal{S}^{(i)2} &= |\check{S}_1^{(i)}|^2 + |\check{S}_2^{(i)}|^2 + 1/\gamma, \end{aligned}$$

with  $1/\gamma = 0$  to obtain LS LEs. MMSE LEs generalizes the estimation considering  $\gamma \neq 0$  as a confidence value close to the signal-to-noise ratio (SNR), but leads to biased LEs.

Note that, due to the superposition of WH spread data signals,  $\check{S}_1^{(i)}$  and  $\check{S}_2^{(i)}$  can be both zero. For instance, a zero-valued chip occurs with 2% probability for a 4QAM symbol alphabet and a WH spreading code of length 32. Consequently, if we do not want small amplitude chips to cause noise enhancement in ICE, we need to take special care when computing the LS LEs at the data symbol positions. A general MMSE process with an optimal adaptive Wiener filtering, taking into account the prospective LEs bias and the reliability of each decoded chip, would be an untractable solution for high data rate receivers. Therefore, we propose three solutions to compute channel estimates  $\hat{H}^{(i),m,p}$  with a compromise between performance and extra complexity.

• **MLS1)** Our first simple solution will avoid noise enhancement in each iteration of ICE:

$$\begin{bmatrix} \check{H}_{\text{MLS1}}^{(i),1,p} \\ \check{H}_{\text{MLS1}}^{(i),2,p} \end{bmatrix} = \begin{cases} \frac{\sqrt{2}}{\mathcal{S}^{(i)2}} \begin{bmatrix} \check{S}_1^{(i)} & \check{S}_2^{(i)} \\ -(\check{S}_2^{(i)})^* & (\check{S}_1^{(i)})^* \end{bmatrix}^H \cdot \begin{bmatrix} R_1^p \\ R_2^p \end{bmatrix}, & \text{if } \mathcal{S}^{(i)2} > \rho_{\text{th}}, \\ \begin{bmatrix} 0 \\ 0 \end{bmatrix}, & \text{if } \mathcal{S}^{(i)2} \leq \rho_{\text{th}}. \end{cases} \quad (6)$$

However, the estimation error can be important when signal is low. To avoid the bias initiated by MLS1 or MMSE LEs, we should preserve LS in (5), and remove unreliable LEs from  $\mathcal{P}_{\text{ICE}}$ . We prefer to introduce a weighting factor between the computation of LEs and the following filtering, acting as a reliability used as described in the next section.

• **MLS2)** Our second solution, based on LS LE, respects

$$\text{reliability of } \check{H}^{(i),m,p} = \begin{cases} A, & \text{if } \mathcal{S}^{(i)2} > \rho_{\text{th}}, \\ B, & \text{if } \mathcal{S}^{(i)2} \leq \rho_{\text{th}}. \end{cases} \quad (7)$$

We will use  $A = 1$ , and  $B = 10^{-2}$  instead of 0, to avoid the appearance of all-null coefficients in the filtering when low power data sequences occur.

• **MLS3)** Our third solution, based on LS LE, respects

$$\text{reliability of } \check{H}^{(i),m,p} = \mathcal{S}^{(i)2}. \quad (8)$$

### C. Iterative Channel Estimation: complete algorithm

For ICE with one or more iterations ( $i > 0$ ), the following steps have to be executed in each iteration:

1. Reconstruct the transmit signal  $\check{S}_l^{(i),m}$ ,  $\forall \{l\} \in \mathcal{D}$ , from the estimated information bits. Note that we used hard decision decoding in simulations.
2. Calculate the LEs  $\check{H}_l^{(i),m,p}$ ,  $\forall \{l\} \in \mathcal{D}$ , according to (5) or (6).
3. Obtain the final estimate of the channel transfer function between transmit antenna  $m$  and receive antenna  $p$  through filtering the LEs over the set  $\mathcal{P}_{\text{ICE}}$  of all reference symbols, i.e.,

$$\begin{aligned} \hat{H}_{n,l}^{(i),m,p} &= \sum_{\{n',l'\} \in \mathcal{T}_{n,l}} \omega_{n',l'}^{(i)} \check{H}_{n',l'}^{(i),m,p}, \\ \mathcal{T}_{n,l} &\subseteq \mathcal{P}_{\text{ICE}}, \quad \forall \{n,l\} \in \mathcal{D}, \quad (9) \end{aligned}$$

where  $\omega_{n',l'}^{(i)}$  is the Wiener filter coefficient obtained for iteration  $i$ . To simplify the process, we will first use a 1D filter in frequency direction over 3 or 5 adjacent subcarriers. The coefficients are pre-computed from a robust Wiener filter, and weighted by the reliability introduced in (7) or (8) if we choose one of these solutions. Next, another 1D robust Wiener filter is applied in time direction over 3 or 5 adjacent blocks of OFDM symbols.

4. Use the newly estimated CSI  $\hat{H}_l^{(i),m,p}$  from (9) in the subsequent space-time decoder and MUD/SUD block to obtain new estimates of the information bits.

#### IV. SIMULATIONS

This section presents simulation results for a downlink MIMO MC-CDMA system applying WH spreading and Alamouti STBC, with two transmit and two receive antennas, considering perfect CE (PCE), PACE, or ICE.

##### A. Simulation Parameters

At a carrier frequency  $f_c = 5.2$  GHz, the MC-CDMA system transmits 32 OFDM symbols per frame (Figure 1(c)) divided into 768 useful data subcarriers over a bandwidth of 46.2 MHz resulting in a subcarrier spacing of  $\Delta f = 60$  kHz. The size of the fast Fourier transform for OFDM modulation is 1024. Thus, the sampling duration is  $T_{\text{sp1}} = 1/61.44$  MHz = 16.276 ns. The guard interval  $T_{\text{GI}}$  is set to  $256 T_{\text{sp1}}$ . The system uses a  $R_c = 1/2$  convolutional mother code with generator polynomials  $(561, 753)_8$ , QAM symbols with Gray mapping, and WH spreading codes of length  $L = 32$ . In the case of 64QAM modulation, the mother code is punctured to a rate  $R_c = 3/4$ . Except for the single-user bound (SUB) that uses maximum-ratio combining (MRC) for 1 user,  $K = 32$  users transmit in parallel  $M = 24$  data symbols per OFDM symbol that are not frequency interleaved [11]. Six pilot OFDM symbols are inserted into the frame as in Figure 1(c), clustering two consecutive pilots and spacing the clusters 12 data symbols apart. So, out of the total 32 OFDM symbols in a frame, 24 are dedicated to data transmission. The resulting data rate varies between 27.65 and 124.4 Mbit/s for 4QAM,  $R_c = 1/2$  and 64QAM,  $R_c = 3/4$ , respectively.

In the simulations the channel is based on 3GPP/SCM definition [9, 2] for a MIMO channel exploiting multipath angular characteristics. This model provides realistic PSDs and correlations based on the sum of rays approach. The model parameters are adapted to  $f_c = 5.2$  GHz and use the BRAN E average power delay profile [10], which refers to a typical outdoor urban multi-path propagation. A velocity of 180 km/h corresponds to a maximum Doppler frequency  $f_{D_{\text{max}}} = 867$  Hz. The two antennas are spaced  $10\lambda$  apart at the base station and  $0.5\lambda$  apart at the mobile terminal. Resultant correlations in frequency-time-space are detailed in [11] with their effect on MIMO MC-CDMA detection.

##### B. Simulation Results

To provide a realistic solution, we focus on a low-complexity detection, i.e., Alamouti MMSE SUD [11], and show the results in the worst case of fully-loaded system with 32 users. The average power of data and pilots is the same, and we use a limited set of coefficients for filters, assuming the same values whatever the modulation, noise, and iteration  $i$ , to verify the robustness of our solutions with parameter mismatches. We set  $\rho_{\text{th}} = 10^{-2}$ . Since the system proposal uses full pilot OFDM symbols, frequency filtering mainly mitigates noisy LEs; thus, we generally use 5 coefficients at low SNR scenarios, and only 3 coefficients at high SNR. Note that using pre-computed coefficients gives almost the same results as performing a simple averaging. For PACE, a robust Wiener filter is then applied in time direction with 3 coefficients to compute

the final estimates in (4) from the 3 LEs in (2). The Doppler PSDs are assumed uniformly distributed with a maximum frequency  $f_{D_{\text{max}}}$ . To maintain a low filtering complexity in ICE, we mainly apply (9) with 3 or 5 coefficients in time direction, on consecutive pilot and data LEs.

In the results,  $E_{\text{bt}}/N_0$  denotes the total energy per bit over the average noise spectral density at each receive antenna [8]. The legend  $f \times T Y$  denotes the filtering size in frequency and time, and  $\#i$  the number of iterations  $i$ .

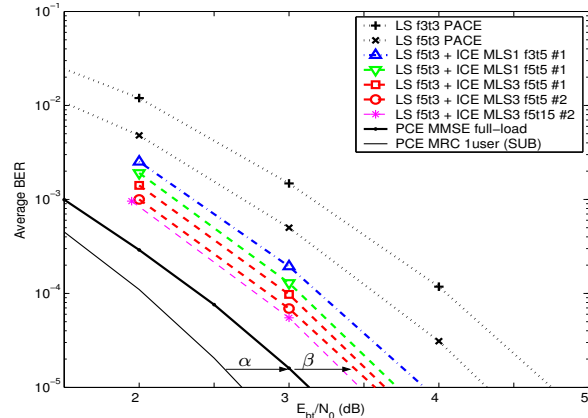

Figure 2: Performance of 4QAM,  $R_c = 1/2$ , 180 km/h.

Figure 2 compares the performance of PCE, PACE and ICE for a fully-loaded system with a global rate 1 (QPSK,  $R_c = 1/2$ ) at high speed (180 km/h). Dashed lines represent the BER results of ICE schemes, and show that our MLS3 solution with a filtering over 5 subcarriers and 5 time coefficients provides the best performance. This simple solution with 2 iterations presents a degradation  $\beta$  inferior to 0.5 dB compared to PCE, that is only  $\alpha = 0.4$  dB from the SUB. The small shift  $\alpha$  with load is due to the fact that spread chips are placed on adjacent subcarriers, where channel coefficients are strongly correlated and cause only little multiple access interference. As the CE degradation  $\beta$  is mainly due to noisy LEs for low data rate scenarios, performance can be improved increasing the filtering length, especially in frequency. More filtering in time, as shown by the “best-setup” curve f5t15 that uses a time filter over the full frame, only brings a low gain. With MLS1, performance is degraded compared to MLS3, whatever the optimization of  $\rho_{\text{th}}$ . MLS2 and MMSE solutions act between MLS1 and MLS3 and are not depicted.

Figure 3 considers a global rate 4.5 (64QAM,  $R_c = 3/4$ ). The slope of the curves increases with  $i$ . When the channel is in deep fade, the error propagation of the hard decision feedback degrades BER performance. However, at high SNR, the degradation  $\beta$  gets down below 1 dB for  $\text{BER} \leq 10^{-5}$ . Our MLS3 solution with a filtering on only 3 subcarriers and 5 time coefficients presents good results, especially in terms of frame error rate (FER), where the degradation after 2 iterations is only 0.5 dB compared to PCE, and reduces to 0.2 dB with the “best-setup” curve. In contrast to the 4QAM case, the channel estimation error (CEE) for PACE at high  $E_{\text{bt}}/N_0$  is dominated by the interpolation error between the LEs in time direction. Thus, a good filtering in time and additional LEs using MLS reduces

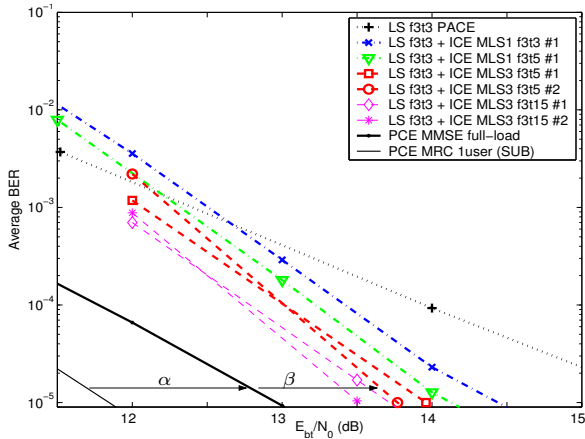

Figure 3: Performance of 64QAM,  $R_c = 3/4$ , 180 km/h.

the interpolation error in (9) and ICE outperforms PACE at the cost of increased complexity.

As a remark, CEE, BER and FER are not behaving the same way. In the configuration of Figure 3, while the gain from PACE to ICE is around 1 dB to obtain  $\text{BER} = 10^{-4}$  and is not increasing with iterations, the gain is superior to 2 dB for FER and increases with  $i$ . Iterations allow to gather packets of errors, and remove scattered errors. Thus, we propose as better measure of performance for packet-based transmissions the throughput versus SNR in Figure 4, computed from perfectly received frames [8]. At a given SNR, the data rate can nearly double using ICE MLS3 compared to PACE, especially for high data rate and high speed scenarios. For instance, at 18 dB, PACE can hardly provide 60 Mbit/s while ICE MLS1 provides 94 Mbit/s. MLS3 can offer 10 or 17 extra Mbit/s with 1 or 2 iterations respectively, and this difference can increase with speed.

## V. SUMMARY AND CONCLUSIONS

In this paper, we present a downlink MIMO MC-CDMA system with WH spreading codes and orthogonal STBCs using PACE and ICE at the receiver. Till moderate speeds (60 km/h), PACE with robust filtering results in less than 1 dB SNR loss and is a solution for most applications. At higher speeds, low data rate scenarios mainly require a good smoothing or averaging in frequency to decrease the noise on LEs while high data rate scenarios become very sensitive to channel variations. In addition to a good filtering in time, high modulations require channel tracking; then, ICE is the unique solution to get close to PCE at the cost of extra complexity. Since the superposition of WH spread data signals can result in zero-valued chips, we propose methods to use estimates of the transmitted data as reference signals for ICE without implying noise enhancement at each iteration. Our MLS3 solution combined with robust filtering presents better throughput performance than traditional LS or MMSE LEs without causing more complexity and avoids error propagation and noise enhancement. As a result, MLS3 shows a faster convergence than other MLS solutions. Moreover, this trade-off preserves the use of a simple robust Wiener filter optimized for unbiased LEs, allowing pre-computed co-

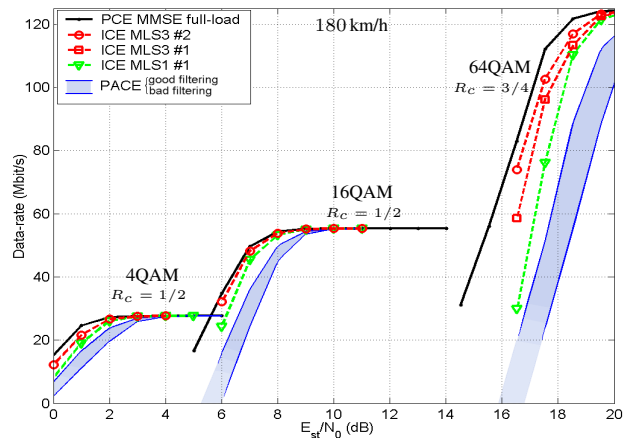

Figure 4: Throughput obtained for different CE and rates.

efficient. We do not need to optimize a threshold or measure precise channel parameters like noise or PSDs.

To conclude, this work is a first step towards high data rate solutions, and further optimizations can fill the gap to PCE. In particular, an adaptation of the filtering with iterations and soft decision feedback should reduce the effect of error propagation. Besides, the iterative receiver should benefit from using the soft decision feedback as a-priori information in the STBC detector and the demodulator.

## ACKNOWLEDGMENT

This research has been conducted within the Network of Excellence in Wireless Communications (NEWCOM) and 4MORE (4G MC-CDMA multiple antenna system On chip for Radio Enhancements). The authors would like to acknowledge the European Commission for this support.

## REFERENCES

- [1] K. Fazel and S. Kaiser, *Multi-Carrier and Spread Spectrum Systems*. John Wiley and Sons, 2003.
- [2] IST-MATRICE project [online] <http://www.ist-matrice.org>.
- [3] IST-4MORE project [online] <http://www.ist-4more.org>.
- [4] S. M. Alamouti, "A simple transmit diversity technique for wireless communications," *IEEE J. Select. Areas Commun.*, Oct. 1998.
- [5] V. Mignone and A. Morello, "CD3-OFDM: A novel demodulation scheme for fixed and mobile receivers," *IEEE Trans. Commun.*, pp. 1144–1151, Sept. 1996.
- [6] F. Sanzi, S. Jelting, and J. Speidel, "A comparative study of iterative channel estimators for mobile OFDM systems," *IEEE Trans. Wireless Commun.*, pp. 849–859, Sept. 2003.
- [7] S. Sand, R. Raulefs, and G. Auer, "Iterative channel estimation for high mobility broadband MC-CDMA systems," in *Proc. of IEEE ICC 2005, Seoul, Korea*, May 2005.
- [8] F. Portier, *et al.*, "Transmission techniques for downlink multi-antenna MC-CDMA systems in a Beyond-3G context," *Journal of Communications and Networks*, vol. 7, pp. 157–170, Jun. 2005.
- [9] 3GPP2 TR 25.996, "Network spatial channel model for multiple input multiple output simulations (release 6)," Apr. 2003.
- [10] ETSI, "Broadband Radio Access Networks (BRAN); HIPERLAN Type 2; Physical Layer," Dec. 2001.
- [11] F. Portier, J.-Y. Baudais, and J.-F. Héland, "Performance of STBC MC-CDMA systems over outdoor realistic MIMO channels," in *Proc. of IEEE VTC'04*, vol. 4, Los Angeles, USA, Sept. 2004.