

Solving two-point boundary value problems using generating functions: Theory and Applications to optimal control and the study of Hamiltonian dynamical systems*

V.M. Guibout[†] and D.J.Scheeres[‡]

University of Michigan, Ann Arbor, Michigan

Abstract

A methodology for solving two-point boundary value problems in phase space for Hamiltonian systems is presented. Using Hamilton-Jacobi theory in conjunction with the canonical transformation induced by the phase flow, we show that the generating functions for this transformation solve any two-point boundary value problem in phase space. Properties of the generating functions are exposed, we especially emphasize multiple solutions, singularities, relations with the state transition matrix and symmetries. Then, we show that using Hamilton's principal function we are also able to solve two-point boundary value problems, nevertheless both methodologies have fundamental differences that we explore. Finally, we present some applications of this theory. Using the generating functions for the phase flow canonical transformation we are able to solve the optimal control problem (without an initial guess), to study phase space structures in Hamiltonian dynamical systems (periodic orbits, equilibrium points) and classical targeting problems (this last topic finds its applications in the design of spacecraft formation trajectories, reconfiguration, formation keeping, etc...).

1 Introduction

One of the most famous two-point boundary value problems in astrodynamics is Lambert's problem, which consists of finding a trajectory in the two-body problem which goes through two

*Abbreviated title: Solving two-point boundary value problems.

[†]Graduate Research Assistant, PhD Candidate, Aerospace Engineering Department, FXB Building, 1320 Beal Avenue, Ann Arbor, MI 48109-2140, guibout@umich.edu

[‡]Associate Professor, Senior member AIAA, Aerospace Engineering Department, FXB Building, 1320 Beal Avenue, Ann Arbor, MI 48109-2140, scheeres@umich.edu

given points in a given lapse of time. Even though the two-body problem is integrable, no analytical solution has been found to this problem so far, and solving Lambert’s problem still requires one to solve Kepler’s equation, which has motivated many papers since 1650 [5]. For a general Hamiltonian dynamical system, a two-point boundary value problem is solved using shooting methods combined with Newton iteration. Though very systematic, this technique requires a “good” initial guess for convergence and is not appropriate when several boundary value problems need to be solved. In order to design a change of configuration of a formation of n spacecraft, $n!$ two-point boundary value problems need to be solved [18], hence for a large collection of spacecraft the shooting method is not efficient. In this paper we address a technique which allows us to solve m boundary value problems at the cost of m function evaluations once generating functions for the canonical transformation induced by the phase flow are known. These generating functions are solutions of the Hamilton-Jacobi equation and for a certain class of problem they can be found offline, that is during mission planning. Moreover, the theory we expose allows us to formally solve any kind of two-point boundary value problem, that is, given a n -dimensional Hamiltonian system and $2n$ coordinates among the $4n$ defining two points in the phase space, we find the other $2n$ coordinates. The Lambert problem is a particular case of this problem where the dynamics is Keplerian, the position of two points are given and the corresponding momenta need to be found. Another instance of such a problem is the search for trajectories which go through two given points in the momentum space (i.e., the conjugate of the Lambert problem). Properties of the solutions found are studied, such as multiple solutions, symmetries and relation to the state transition matrix for linear systems. Then, we expose another method to solve two-point boundary value problems based on Hamilton’s principal function and study how it compares to generating functions. Finally, we present direct applications of this theory through the optimal control problem and the study of some Hamiltonian dynamical systems. Solving the optimal control problem using generating functions was first introduced by Scheeres et al. [17], we will review their method in this paper and expand it to more general optimal control problems. Applications to Hamiltonian dynamical systems were first studied by Guibout and Scheeres [9, 10] for spacecraft formation flight design and for the computation of periodic orbits.

2 Solving a two-point boundary value problem

In this section, we recall the principle of least action for Hamiltonian systems and derive the Hamilton-Jacobi equation. Local existence of generating functions is proved. We underline that we do not study global properties. In general, we do not know a priori if the generating functions will

be defined for all time and in most of the cases we found that they develop singularities. We refer the reader to [1, 2, 7, 8, 9, 13, 14] for more details on local Hamilton-Jacobi theory, [1, 2, 14] for global theory and [6, 1, 2] and section 2.3.4 of this paper for a study of singularities.

2.1 The Hamilton-Jacobi theory

Let (P, ω, X_H) be a Hamiltonian system with n degrees of freedom, and $H : P \times \mathbb{R} \rightarrow \mathbb{R}$ the Hamiltonian function. In the extended phase space $P \times \mathbb{R}$, we consider an integral curve of the vector field X_H connecting the points (q_0, p_0, t_0) and (q_1, p_1, t_1) . The principle of least action reads:

Theorem 2.1. (*The principle of least action in phase space*) *The integral $\int_0^1 pdq - Hdt$ has an extremal in the class of curve γ whose ends lie in the n -dimensional subspaces $(t = t_0, q = q_0)$ and $(t = t_1, q = q_1)$ of extended phase space.*

Proof. We proceed to the computation of the variation.

$$\begin{aligned} \delta \int_{\gamma} (p\dot{q} - H)dt &= \int_{\gamma} \left(\dot{q}\delta p + p\delta\dot{q} - \frac{\partial H}{\partial q}\delta q - \frac{\partial H}{\partial p}\delta p \right) dt \\ &= [p\delta q]_0^1 + \int_{\gamma} \left[\left(\dot{q} - \frac{\partial H}{\partial p} \right) \delta p - \left(\dot{p} + \frac{\partial H}{\partial q} \right) \delta q \right] dt \end{aligned} \quad (2.1)$$

Therefore, since the variation vanishes at the end points, the integral curves of the Hamiltonian vector field are the only extremals. \square

Remark 2.1. The condition for a curve γ to be an extremal of a functional does not depend on the choice of coordinate system, therefore the principle of least action is coordinate invariant.

Now let (P_1, ω_1) and (P_2, ω_2) be symplectic manifolds,

Definition 2.1. A smooth map $f : P_1 \times \mathbb{R} \rightarrow P_2 \times \mathbb{R}$ is a canonical transformation if and only if

- (1)- f is a C^∞ -diffeomorphism,
- (2)- f preserves the time, i.e., there exists a function g_t such that $f(x, t) = (g_t(x), t)$,
- (3)- for each t , $g_t : P_1 \rightarrow P_2$ as defined above is a symplectic diffeomorphism and f preserves the canonical form of Hamilton's equations.

All three points in this definition are not independent but we mention them for sake of clarity. It can be proved [1] that if g_t is symplectic then f is a diffeomorphism. Moreover, the third point of the definition differs from book to book. We chose Abraham's definition [1] but very often the third item reduces to " f preserves Hamilton's equations" (Goldstein [7], Greenwood [8]). Arnold [2]

argues that this definition differs from the original definition, the third item should actually be “ g_t is symplectic” which implies, but is not equivalent to, “ f preserves the canonical form of Hamilton’s equations”.

Consider a canonical transformation $f : (q_i, p_i, t) \mapsto (Q_i, P_i, t)$. Since Hamilton’s equations are preserved, we have:

$$\begin{cases} \dot{Q}_i = \frac{\partial K}{\partial P_i} \\ \dot{P}_i = -\frac{\partial K}{\partial Q_i} \end{cases} \quad (2.2)$$

where $K = K(Q, P, t)$ is the Hamiltonian of the system in the new set of coordinates.

On the other hand, we have seen that the principle of least action is coordinate invariant. Hence:

$$\delta \int_{t_0}^{t_1} \left(\sum_{i=1}^n p_i \dot{q}_i - H(q, p, t) \right) dt = 0 \quad (2.3)$$

$$\delta \int_{t_0}^{t_1} \left(\sum_{i=1}^n P_i \dot{Q}_i - K(Q, P, t) \right) dt = 0 \quad (2.4)$$

From Eqns. 2.3 - 2.4, we conclude that the integrands of the two integrals differ at most by a total time derivative of an arbitrary function F :

$$\sum_{i=1}^n p_i dq_i - H dt = \sum_{j=1}^n P_j dQ_j - K dt + dF \quad (2.5)$$

Such a function is called a generating function for the canonical transformation f and is, *a priori*, a function of both the old and the new variables and time. The two sets of coordinates being connected by the $2n$ equations, namely, $f(q_1, \dots, q_n, p_1, \dots, p_n, t) = (Q_1, \dots, Q_n, P_1, \dots, P_n, t)$, F can be reduced to a function of $2n+1$ variables among the $4n+1$. Hence, we can define 4^n generating functions that have n variables in P_1 and n in P_2 . Among these are the four kinds defined by Goldstein [7], $F_1(q_1, \dots, q_n, Q_1, \dots, Q_n, t)$, $F_2(q_1, \dots, q_n, P_1, \dots, P_n, t)$, $F_3(p_1, \dots, p_n, Q_1, \dots, Q_n, t)$ and $F_4(p_1, \dots, p_n, P_1, \dots, P_n, t)$.

Let us first consider the generating function $F_1(q, Q, t)$. The total time derivative of F_1 reads:

$$dF_1(q, Q, t) = \sum_{i=1}^n \frac{\partial F_1}{\partial q_i} dq_i + \sum_{j=1}^n \frac{\partial F_1}{\partial Q_j} dQ_j + \frac{\partial F_1}{\partial t} dt \quad (2.6)$$

Hence Eq. 2.5 yields:

$$\sum_{i=1}^n (p_i - \frac{\partial F_1}{\partial q_i}) dq_i - H dt = \sum_{j=1}^n (P_j + \frac{\partial F_1}{\partial Q_j}) dQ_j - K dt + \frac{\partial F_1}{\partial t} dt \quad (2.7)$$

Assume that (q, Q, t) is a set of independent variables, then Eq. 2.7 is equivalent to:

$$p_i = \frac{\partial F_1}{\partial q_i}(q, Q, t) \quad (2.8)$$

$$P_i = -\frac{\partial F_1}{\partial Q_i}(q, Q, t) \quad (2.9)$$

$$K(Q, -\frac{\partial F_1}{\partial Q}, t) = H(q, \frac{\partial F_1}{\partial q}, t) + \frac{\partial F_1}{\partial t} \quad (2.10)$$

If (q, Q) is not a set of independent variables, we say that F_1 is singular.

Now let us consider more general generating functions. Let $(i_1, \dots, i_p)(i_{p+1}, \dots, i_n)$ and $(k_1, \dots, k_r)(k_{r+1}, \dots, k_n)$ be two partitions of the set $(1, \dots, n)$ into two non-intersecting parts such that $i_1 < \dots < i_p, i_{p+1} < \dots < i_n, k_1 < \dots < k_r$ and $k_{r+1} < \dots < k_n$ and define $I_p = (i_1, \dots, i_p)$, $\bar{I}_p = (i_{p+1}, \dots, i_n)$, $K_r = (k_1, \dots, k_r)$ and $\bar{K}_r = (k_{r+1}, \dots, k_n)$. If

$$(q_{I_p}, p_{\bar{I}_p}, Q_{K_r}, P_{\bar{K}_r}) = (q_{i_1}, \dots, q_{i_p}, p_{i_{p+1}}, \dots, p_{i_n}, Q_{k_1}, \dots, Q_{k_r}, P_{k_{r+1}}, \dots, P_{k_n})$$

are independent variables, then we can define the generating function F_{I_p, K_r} :

$$F_{I_p, K_r}(q_{I_p}, p_{\bar{I}_p}, Q_{K_r}, P_{\bar{K}_r}, t) = F(q_{i_1}, \dots, q_{i_p}, p_{i_{p+1}}, \dots, p_{i_n}, Q_{k_1}, \dots, Q_{k_r}, P_{k_{r+1}}, \dots, P_{k_n}, t) \quad (2.11)$$

Expanding dF_{I_p, K_r} yields:

$$dF_{I_p, K_r} = \sum_{a=1}^p \frac{\partial F_{I_p, K_r}}{\partial q_{i_a}} dq_{i_a} + \sum_{a=p+1}^n \frac{\partial F_{I_p, K_r}}{\partial p_{i_a}} dp_{i_a} + \sum_{a=1}^r \frac{\partial F_{I_p, K_r}}{\partial Q_{k_a}} dQ_{k_a} + \sum_{a=r+1}^n \frac{\partial F_{I_p, K_r}}{\partial P_{k_a}} dP_{k_a} + \frac{\partial F_{I_p, K_r}}{\partial t} dt \quad (2.12)$$

and rewriting Eq. 2.5 as a function of the linearly independent variables leads to:

$$\sum_{a=1}^p p_{i_a} dq_{i_a} - \sum_{a=p+1}^n q_{i_a} dp_{i_a} - H dt = \sum_{a=1}^r P_{k_a} dQ_{k_a} - \sum_{a=r+1}^n Q_{k_a} dP_{k_a} - K dt + dF_{I_p, K_r} \quad (2.13)$$

where $F_{I_p, K_r} = F_1 + \sum_{a=r+1}^n Q_{k_a} P_{k_a} - \sum_{a=p+1}^n q_{i_a} p_{i_a}$. This last relation defines the Legendre transformation, which allows one to transform one generating function into another.

Then Eq. 2.13 reads:

$$\begin{aligned} \sum_{a=1}^r (P_{k_a} + \frac{\partial F_{I_p, K_r}}{\partial Q_{k_a}}) dQ_{k_a} &- \sum_{a=r+1}^n (-Q_{k_a} + \frac{\partial F_{I_p, K_r}}{\partial P_{k_a}}) dP_{k_a} - K dt + \frac{\partial F_{I_p, K_r}}{\partial t} dt \\ &= \sum_{a=1}^p (p_{i_a} - \frac{\partial F_{I_p, K_r}}{\partial q_{i_a}}) dq_{i_a} \sum_{a=p+1}^n (-q_{i_a} - \frac{\partial F_{I_p, K_r}}{\partial p_{i_a}}) dp_{i_a} - H dt \end{aligned} \quad (2.14)$$

which is equivalent to:

$$p_{I_p} = \frac{\partial F_{I_p, K_r}}{\partial q_{I_p}}(q_{I_p}, p_{\bar{I}_p}, Q_{K_r}, P_{\bar{K}_r}, t) \quad (2.15)$$

$$q_{\bar{I}_p} = -\frac{\partial F_{I_p, K_r}}{\partial p_{\bar{I}_p}}(q_{I_p}, p_{\bar{I}_p}, Q_{K_r}, P_{\bar{K}_r}, t) \quad (2.16)$$

$$P_{K_r} = -\frac{\partial F_{I_p, K_r}}{\partial Q_{K_r}}(q_{I_p}, p_{\bar{I}_p}, Q_{K_r}, P_{\bar{K}_r}, t) \quad (2.17)$$

$$Q_{\bar{K}_r} = \frac{\partial F_{I_p, K_r}}{\partial P_{\bar{K}_r}}(q_{I_p}, p_{\bar{I}_p}, Q_{K_r}, P_{\bar{K}_r}, t) \quad (2.18)$$

$$K(Q_{K_r}, \frac{\partial F_{I_p, K_r}}{\partial P_{\bar{K}_r}}, -\frac{\partial F_{I_p, K_r}}{\partial Q_{K_r}}, P_{\bar{K}_r}, t) = H(q_{I_p}, -\frac{\partial F_{I_p, K_r}}{\partial p_{\bar{I}_p}}, \frac{\partial F_{I_p, K_r}}{\partial q_{I_p}}, p_{\bar{I}_p}, t) + \frac{\partial F_{I_p, K_r}}{\partial t} \quad (2.19)$$

For the case where the partitions are $(1, \dots, n)()$ and $()(1, \dots, n)$ (i.e., $p = n$ and $r = 0$), we recover the generating function F_2 , which verifies the following equations:

$$p_i = \frac{\partial F_2}{\partial q_i}(q, P, t) \quad (2.20)$$

$$Q_i = \frac{\partial F_2}{\partial P_i}(q, P, t) \quad (2.21)$$

$$K(\frac{\partial F_2}{\partial P}, P, t) = H(q, \frac{\partial F_2}{\partial q}, t) + \frac{\partial F_2}{\partial t} \quad (2.22)$$

The case $p = 0$ and $r = n$ corresponds to a generating function of the third kind, F_3 :

$$q_i = -\frac{\partial F_3}{\partial p_i}(p, Q, t) \quad (2.23)$$

$$P_i = -\frac{\partial F_3}{\partial Q_i}(p, Q, t) \quad (2.24)$$

$$K(Q, -\frac{\partial F_3}{\partial Q}, t) = H(-\frac{\partial F_3}{\partial p}, p, t) + \frac{\partial F_3}{\partial t} \quad (2.25)$$

Finally, if $p = 0$ and $r = 0$, we obtain F_4 :

$$q_i = \frac{\partial F_4}{\partial p_i}(p, P, t) \quad (2.26)$$

$$Q_i = -\frac{\partial F_4}{\partial P_i}(p, P, t) \quad (2.27)$$

$$K\left(-\frac{\partial F_4}{\partial P}, P, t\right) = H\left(\frac{\partial F_4}{\partial p}, p, t\right) + \frac{\partial F_4}{\partial t} \quad (2.28)$$

2.2 The phase flow is a canonical transformation

In the following we focus on a specific canonical transformation, the one induced by the phase flow. Let Φ_t be the flow of an Hamiltonian system:

$$\begin{aligned} \Phi_t : P &\rightarrow P \\ (q_0, p_0) &\mapsto (\Phi_t^1(q_0, p_0) = q(q_0, p_0, t), \Phi_t^2(q_0, p_0) = p(q_0, p_0, t)) \end{aligned} \quad (2.29)$$

Then, the phase flow induces a transformation ϕ on $P \times \mathbb{R}$ defined as follows:

$$\phi : (q_0, p_0, t) \mapsto (\Phi_t(q_0, p_0), t) \quad (2.30)$$

Theorem 2.2. *The transformation ϕ induced by the phase flow is canonical.*

Proof. The proof of this theorem can be found in Arnold [2], it is based on the integral invariant of Poincaré-Cartan. \square

For such a transformation, (Q, P) represents the initial conditions of the system (q_0, p_0) , the Hamiltonian function K is a constant that can be chosen to be 0 and the equations verified by the generating function F_{I_p, K_r} become:

$$p_{I_p} = \frac{\partial F_{I_p, K_r}}{\partial q_{I_p}}(q_{I_p}, p_{\bar{I}_p}, q_{0_{K_r}}, p_{0_{\bar{K}_r}}, t), t) \quad (2.31)$$

$$q_{\bar{I}_p} = -\frac{\partial F_{I_p, K_r}}{\partial p_{\bar{I}_p}}(q_{I_p}, p_{\bar{I}_p}, q_{0_{K_r}}, p_{0_{\bar{K}_r}}, t), t) \quad (2.32)$$

$$p_{0_{K_r}} = -\frac{\partial F_{I_p, K_r}}{\partial q_{0_{K_r}}}(q_{I_p}, p_{\bar{I}_p}, q_{0_{K_r}}, p_{0_{\bar{K}_r}}, t), t) \quad (2.33)$$

$$q_{0_{\bar{K}_r}} = \frac{\partial F_{I_p, K_r}}{\partial p_{0_{\bar{K}_r}}}(q_{I_p}, p_{\bar{I}_p}, q_{0_{K_r}}, p_{0_{\bar{K}_r}}, t), t) \quad (2.34)$$

$$0 = H\left(q_{I_p}, -\frac{\partial F_{I_p, K_r}}{\partial p_{\bar{I}_p}}, \frac{\partial F_{I_p, K_r}}{\partial q_{I_p}}, p_{\bar{I}_p}, t\right) + \frac{\partial F_{I_p, K_r}}{\partial t} \quad (2.35)$$

The last equation is often referred to as the Hamilton-Jacobi equation. To solve this equation, one needs boundary conditions. At the initial time, position and momentum (q, p) are equal to the initial conditions (q_0, p_0) . Hence, F_{I_p, K_r} must generate the identity transformation at the initial time.

2.3 Properties of the canonical transformation induced by the phase flow

In this section we study the properties of generating functions for the phase flow canonical transformation. First we show that they solve a two-point boundary value problem, and then we prove a few results on singularities, symmetries and differentiability. In particular, we relate the generating functions and the state transition matrix for a linear system.

2.3.1 Solving a two-point boundary value problem

Consider two points in phase space, $X_0 = (q_0, p_0)$ and $X_1 = (q, p)$, and two partitions of $(1, \dots, n)$ into two non-intersecting parts, $(i_1, \dots, i_p)(i_{p+1}, \dots, i_n)$ and $(k_1, \dots, k_r)(k_{r+1}, \dots, k_n)$. A two-point boundary value problem is formulated as follows:

Given $2n$ coordinates $(q_{i_1}, \dots, q_{i_p}, p_{i_{p+1}}, \dots, p_{i_n})$ and $(q_{0_{k_1}}, \dots, q_{0_{k_r}}, p_{0_{k_{r+1}}}, \dots, p_{0_{k_n}})$, find the remaining $2n$ variables such that a particle starting at X_0 will reach X_1 in T units of time.

From the relationship defined by Eqns. 2.15, 2.16, 2.17 and 2.18, we see that the generating function F_{I_p, K_r} solves this problem. Lambert's problem is a particular case of boundary value problem where the partitions of $(1, \dots, n)$ are $(1, \dots, n)()$ and $(1, \dots, n)()$. Though, given two positions q_f and q_0 and a transfer time T , the corresponding momentum vectors are found from the relationships verified by F_1 :

$$\begin{aligned} p_i &= \frac{\partial F_1}{\partial q_i}(q, q_0, T) \\ p_{0_i} &= -\frac{\partial F_1}{\partial q_{0_i}}(q, q_0, T) \end{aligned} \tag{2.36}$$

2.3.2 Existence and properties of the generating functions

In the first section we proved the existence of a generating function using the assumption that its variables are linearly independent. This is not always true at every instant. As an example let us look at the harmonic oscillator. The equations of motion are given by:

$$q(t) = q_0 \cos(\omega t) + p_0/\omega \sin(\omega t) \tag{2.37}$$

$$p(t) = -q_0\omega \sin(\omega t) + p_0 \cos(\omega t) \tag{2.38}$$

At $T = 2\pi/\omega + 2k\pi$, we have $q(T) = q_0$, that is (q, q_0) are not independent variables and the generating function F_1 is undefined at this instant. We say that F_1 is singular at T . We now prove that at least one of the generating functions is not singular at every instant.

Proposition 2.3. *Consider the flow Φ_t of an Hamiltonian system $\phi : (q_0, p_0, t) \mapsto (\Phi_t(q_0, p_0), t)$, where*

$$\Phi_t : (q_0, p_0) \mapsto (\Phi_t^1(q_0, p_0) = q(q_0, p_0, t), \Phi_t^2(q_0, p_0) = p(q_0, p_0, t))$$

For every t , there exists two subsets of cardinal n of the set $(1, \dots, 2n)$, I_n and K_n , such that

$$\det \left(\frac{\partial \tilde{\Phi}_{t_i}}{\partial z_j} \right)_{i \in I_n, j \in K_n} \neq 0 \quad (2.39)$$

where $\tilde{\Phi}_t(q, p, q_0, p_0) = (\tilde{\Phi}_t^1(q, q_0, p_0) = q - \Phi_t^1(q_0, p_0), \tilde{\Phi}_t^2(p, q_0, p_0) = p - \Phi_t^2(q_0, p_0))$ and $z = (q_0, p_0)$

Proof. To prove this property, we only need to notice that Φ_t is a diffeomorphism, i.e., $\tilde{\Phi}_{t_i \in I_n}$ is an injection, therefore, there exists at least one n -dimensional subspace on which the restriction of $\tilde{\Phi}_{t_i \in I_n}$ is a diffeomorphism. \square

Theorem 2.4. *At every instant, at least one generating function is well-defined. Moreover, when they exist, generating functions define local C^∞ -diffeomorphism.*

Proof. From the previous theorem, there exists I_n and K_n such that $\det \left(\frac{\partial \tilde{\Phi}_{t_i}}{\partial z_j} \right)_{i \in I_n, j \in K_n} \neq 0$. Without any loss of generality and for simplicity, let the partition be $I_n = (1, \dots, n) = K_n$, then we have:

$$\det \left(\frac{\partial \tilde{\Phi}_t^1(q, q_0, p_0)}{\partial q_0} \right) \neq 0 \quad (2.40)$$

Moreover, $\tilde{\Phi}_t^1$ verifies:

$$\tilde{\Phi}_t^1(q, q_0, p_0) = 0 \quad (2.41)$$

From the local inversion theorem there exists a local diffeomorphism f_1 in a neighborhood of (q_0, p_0) such that $q_0 = f_1(q, p_0)$. In addition, the flow defines p as a function of (q_0, p_0) , i.e., replacing q_0 by $f_1(q, p_0)$, we obtain $(q_0, p) = (f_1(q, p_0), f_2(q, p_0))$ where $f_2(q, p_0) = \Phi_t^2(f_1(q, p_0), p_0)$. This equation is equivalent to the two equations verified by F_2 , hence $f_1 = \frac{\partial F_2}{\partial p_0}$ and $f_2 = \frac{\partial F_2}{\partial q}$. This proves that F_2 exists and since Φ_t is C^∞ , F_2 defines a local C^∞ -diffeomorphism from (q, p_0) to (p, q_0) . \square

Remark 2.2. The theorem above can be stated for generating functions associated with an arbitrary canonical transformation, not only the one induced by the phase flow. To proceed the above proof

we only required that the flow defines a C^∞ -diffeomorphism, this property is shared by all canonical transformations.

Through the harmonic oscillator example, we saw that a generating function may become singular. We now characterize singularities and give a physical interpretation to them.

Proposition 2.5. *The generating function F_{I_p, K_r} is singular at time t if and only if*

$$\det \left(\frac{\partial \tilde{\Phi}_{t_i}}{\partial z_j} \right)_{i \in I, j \in J} = 0 \quad (2.42)$$

where $I = \{i \in I_p\} \cup \{n + i, i \in \bar{I}_p\}$ and $J = \{j \in \bar{K}_r\} \cup \{n + j, j \in K_r\}$.

Proof. The proof proceeds as the previous one, it is also based on local inversion theorem. \square

From the above theorem, we deduce that a generating function is singular when there exists multiple solutions to the boundary value problem. In the harmonic oscillator example, whatever the initial momentum is, the initial position and position at time $T = 2\pi/\omega + 2k\pi$ are equal.

Finally, if the Hamiltonian function is independent of time, the system is reversible and therefore the generating functions F_{I_p, K_r} and F_{K_r, I_p} are similar in the sense that there exists a diffeomorphism which transforms one into the other. In particular, they develop singularities at the same instant. If $p = n$ and $r = 0$, we obtain that F_2 and F_3 are similar.

2.3.3 Linear systems theory

In this section we particularize the theory developed above to linear systems. The following developments have implication in the study of relative motion and in optimal control theory as we will see later. Further, using linear systems theory, we are able to characterize singularities of generating functions using the state transition matrix.

Hamilton-Jacobi equation When studying the relative motion of two particles, one often linearizes the dynamics about the trajectory of one of the particles (called the nominal trajectory) and then uses a linear approximation of the dynamics to study the motion of the other particle relative to the nominal trajectory (perturbed trajectory). Thus, the study of relative motion reduces to the study of a time-dependent linear Hamiltonian system, i.e., a system with a quadratic Hamiltonian

function without any linear terms [9]:

$$H_h = \frac{1}{2} X_h^T \begin{pmatrix} H_{qq}(t) & H_{qp}(t) \\ H_{pq}(t) & H_{pp}(t) \end{pmatrix} X_h \quad (2.43)$$

where $X_h = \begin{pmatrix} \Delta q \\ \Delta p \end{pmatrix}$ is the relative state vector. Guibout and Scheeres [9] proved that the generating functions for the phase flow transformation must then be quadratic without any linear terms, that is, if we take F_2 for example:

$$F_2 = \frac{1}{2} Y^T \begin{pmatrix} F_{11}^2(t) & F_{12}^2(t) \\ F_{21}^2(t) & F_{22}^2(t) \end{pmatrix} Y \quad (2.44)$$

where $Y = \begin{pmatrix} \Delta q \\ \Delta p_0 \end{pmatrix}$ and $\begin{pmatrix} \Delta q_0 \\ \Delta p_0 \end{pmatrix}$ is the relative state vector at initial time. We also point out that both matrices defining H_h and F_2 are symmetric. Then Eq. 2.20 reads:

$$\begin{aligned} \Delta p &= \frac{\partial F_2}{\partial \Delta q} \\ &= \begin{pmatrix} F_{11}^2(t) & F_{12}^2(t) \end{pmatrix} Y \end{aligned} \quad (2.45)$$

Substituting into Eq. 2.22 yields¹:

$$0 = Y^T \left\{ \begin{pmatrix} \dot{F}_{11}^2(t) & \dot{F}_{12}^2(t) \\ \dot{F}_{12}^2(t)^T & \dot{F}_{22}^2(t) \end{pmatrix} + \begin{pmatrix} I & F_{11}^2(t)^T \\ 0 & F_{12}^2(t)^T \end{pmatrix} \begin{pmatrix} H_{qq}(t) & H_{qp}(t) \\ H_{pq}(t) & H_{pp}(t) \end{pmatrix} \begin{pmatrix} I & 0 \\ F_{11}^2(t) & F_{12}^2(t) \end{pmatrix} \right\} Y \quad (2.46)$$

Though the above equations have been derived using F_2 , they are also valid for F_1 (replacing $Y = \begin{pmatrix} \Delta q \\ \Delta p_0 \end{pmatrix}$ by $Y = \begin{pmatrix} \Delta q \\ \Delta q_0 \end{pmatrix}$) since F_1 and F_2 solve the same Hamilton-Jacobi equation (Eqns. 2.10,

¹For the canonical transformation induced by the phase flow, we have seen that $K = 0$

2.22). Equation 2.46 is equivalent to the following 4 matrix equations:

$$\begin{aligned}
\dot{F}_{11}^{1,2}(t) + H_{qq}(t) + H_{qp}(t)F_{11}^{1,2}(t) + F_{11}^{1,2}(t)H_{pq}(t) + F_{11}^{1,2}(t)H_{pp}(t)F_{11}^{1,2}(t) &= 0 \\
\dot{F}_{12}^{1,2}(t) + H_{qp}(t)F_{12}^{1,2}(t) + F_{11}^{1,2}(t)H_{pp}(t)F_{12}^{1,2}(t) &= 0 \\
\dot{F}_{21}^{1,2}(t) + F_{21}^{1,2}(t)H_{pq}(t) + F_{21}^{1,2}(t)H_{pp}(t)F_{11}^{1,2}(t) &= 0 \\
\dot{F}_{22}^{1,2}(t) + F_{21}^{1,2}(t)H_{pp}(t)F_{12}^{1,2}(t) &= 0
\end{aligned} \tag{2.47}$$

where we replaced F_{ij}^2 by $F_{ij}^{1,2}$ to signify that these equations are valid for both F_1 and F_2 and recall that $F_{21}^{1,2} = F_{12}^{1,2T}$. A similar set of equations can be derived for any generating function F_{I_p, K_r} , here we only give the equations verified by F_3 and F_4 :

$$\begin{aligned}
\dot{F}_{11}^{3,4}(t) + H_{pp}(t) - H_{pq}(t)F_{11}^{3,4}(t) - F_{11}^{3,4}(t)H_{qp}(t) + F_{11}^{3,4}(t)H_{qq}(t)F_{11}^{3,4}(t) &= 0 \\
\dot{F}_{12}^{3,4}(t) - H_{pq}(t)F_{12}^{3,4}(t) + F_{11}^{3,4}(t)H_{qq}(t)F_{12}^{3,4}(t) &= 0 \\
\dot{F}_{21}^{3,4}(t) - F_{21}^{3,4}(t)H_{qp}(t) + F_{21}^{3,4}(t)H_{qq}(t)F_{11}^{3,4}(t) &= 0 \\
\dot{F}_{22}^{3,4}(t) + F_{21}^{3,4}(t)H_{qq}(t)F_{12}^{3,4}(t) &= 0
\end{aligned} \tag{2.48}$$

The first equations of Eqns 2.47 and 2.48 are Ricatti equations, the second and third are non-homogeneous, time varying, linear equations and are equivalent to each other (i.e., transform into each other under transpose), and the last are just a quadrature.

Perturbation matrices Another approach to the study of relative motion of spacecraft is to use the state transition matrix. This method was developed by Battin [4] for the case of a spacecraft moving in a point mass gravity field. Let Φ be the state transition matrix which describes the relative motion:

$$\begin{pmatrix} \Delta q \\ \Delta p \end{pmatrix} = \Phi \begin{pmatrix} \Delta q_0 \\ \Delta p_0 \end{pmatrix} \tag{2.49}$$

where $\Phi = \begin{pmatrix} \Phi_{qq} & \Phi_{qp} \\ \Phi_{pq} & \Phi_{pp} \end{pmatrix}$.

From the state transition matrix, Battin [4] defines the fundamental perturbation matrices C and \tilde{C} as:

$$\begin{aligned}\tilde{C} &= \Phi_{pq}\Phi_{qq}^{-1} \\ C &= \Phi_{pp}\Phi_{qp}^{-1}\end{aligned}\tag{2.50}$$

That is, given $\Delta p_0 = 0$, $\tilde{C}\Delta q = \Delta p$ and given $\Delta q_0 = 0$, $C\Delta q = \Delta p$. He shows that for relative motion of a spacecraft in a point mass gravity field these matrices verify a Ricatti equation and are therefore symmetric. Using the generating functions for the canonical transformation induced by the phase flow, we immediately recover these properties and also show that they are verified for any relative motion of two particles in a Hamiltonian dynamical system.

From Eqns. 2.20 and 2.21:

$$\begin{aligned}\Delta p &= \frac{\partial F_2}{\partial \Delta p_0} \\ &= F_{11}^2 \Delta q + F_{12}^2 \Delta p_0\end{aligned}\tag{2.51}$$

$$\begin{aligned}\Delta q_0 &= \frac{\partial F_2}{\partial \Delta q} \\ &= F_{21}^2 \Delta q + F_{22}^2 \Delta p_0\end{aligned}\tag{2.52}$$

Solving for $(\Delta q, \Delta p)$ yields:

$$\Delta q = F_{21}^2{}^{-1} \Delta q_0 - F_{21}^2{}^{-1} F_{22}^2 \Delta p_0\tag{2.53}$$

$$\Delta p = F_{11}^2 F_{21}^2{}^{-1} \Delta q_0 + (F_{12}^2 - F_{11}^2 F_{21}^2{}^{-1} F_{22}^2) \Delta p_0\tag{2.54}$$

From the above equations we are able to link the state transition matrix to the generating function F_2 .

$$\left\{ \begin{array}{l} \Phi_{qp} = -F_{21}^2{}^{-1} F_{22}^2 \\ \Phi_{qq} = F_{21}^2{}^{-1} \\ \Phi_{pp} = F_{12}^2 - F_{11}^2 F_{21}^2{}^{-1} F_{22}^2 \\ \Phi_{pq} = F_{11}^2 F_{21}^2{}^{-1} \end{array} \right.$$

We conclude that

$$\tilde{C} = \Phi_{pq}\Phi_{qq}^{-1} = F_{11}^2\tag{2.55}$$

In the same manner, but using F_1 , we can show that:

$$C = \Phi_{pp}\Phi_{qp}^{-1} = F_{11}^1 \quad (2.56)$$

Thus, we have shown that C and \tilde{C} are symmetric by nature (as $F_{11}^{1,2}$ is symmetric by definition), and moreover that they verify the Ricatti equation given in Eq. 2.47.

Singularities of generating functions and state transition matrix From Eqns. 2.20, 2.21 and 2.44, we derive a relationship between terms of F_2 and some coefficients of the state transition matrix:

$$\begin{aligned} \Delta p &= \frac{\partial F_2}{\partial \Delta p} \\ &= F_{11}^2 \Delta q + F_{12}^2 \Delta p_0 \\ &\text{but we also have} \\ \Delta p &= \Phi_{pq}\Phi_{qq}^{-1}\Delta q + (\Phi_{pp} - \Phi_{pq}\Phi_{qq}^{-1}\Phi_{qp})\Delta p_0 \end{aligned} \quad (2.57)$$

$$\begin{aligned} \Delta q_0 &= \frac{\partial F_2}{\partial \Delta p_0} \\ &= F_{21}^2 \Delta q + F_{22}^2 \Delta p_0 \\ &\text{but we also have} \\ \Delta q_0 &= \Phi_{qq}^{-1}\Delta q - \Phi_{qq}^{-1}\Phi_{qp}\Delta p_0 \end{aligned} \quad (2.58)$$

Thus:

$$F_{11}^2 = \Phi_{pq}\Phi_{qq}^{-1} \quad (2.59)$$

$$F_{12}^2 = \Phi_{pp} - \Phi_{pq}\Phi_{qq}^{-1}\Phi_{qp} \quad (2.60)$$

$$F_{21}^2 = \Phi_{qq}^{-1} \quad (2.61)$$

$$F_{22}^2 = \Phi_{qq}^{-1}\Phi_{qp} \quad (2.62)$$

$$(2.63)$$

We conclude that if Φ_{qq} is singular, F_2 is also singular. The same analysis can be achieved for the other generating functions, and we find that:

- F_1 is singular when Φ_{qp} is singular,

- F_3 is singular when Φ_{pp} is singular,
- F_4 is singular when Φ_{pq} is singular.

These results can be extended to other generating functions, but requires us to work with another block decomposition of the state transition matrix.

2.3.4 On singularities of generating functions

We have proved local existence of generating functions and mentioned that they may not be globally defined for all time. Using linear system theory we were able to predict where the singularities are and to interpret their meaning as multiple solutions to the two-point boundary value problem. In this section we extend our study to singularities of nonlinear systems.

Lagrangian submanifold Consider an arbitrary generating function F_{I_p, K_r} . Then Eqns. 2.15-2.18 define a $2n$ -dimensional submanifold called a canonical relation [19] of the $4n$ -dimensional symplectic space $P_1 \times P_2$. In addition, since the new variables (Q, P) (or (q_0, p_0)) do not appear in the Hamilton-Jacobi equation 2.35 we may consider them as parameters. In that case Eqns. 2.15 and 2.16 define an n -dimensional submanifold of the symplectic space P_1 called a Lagrangian submanifold [19]. The study of singularities can be achieved using either canonical relations [1] or Lagrangian submanifolds [2, 14].

Theorem 2.6. *The generating function F_{I_p, K_r} is singular if and only if the local projection of the canonical relation \mathcal{L} defined by Eqns. 2.15-2.18 onto $(q_{I_p}, p_{\bar{I}_p}, Q_{K_r}, P_{\bar{K}_r})$ is not a local diffeomorphism.*

Moreover, the projection of such a singular point is called a caustic. If one works with Lagrangian submanifolds then the previous theorem becomes

Theorem 2.7. *The generating function² F_{I_p, K_r} is singular if the local projection of the Lagrangian submanifold defined by Eqns. 2.15 and 2.16 onto $(q_{I_p}, p_{\bar{I}_p})$ is not a local diffeomorphism.*

In light of these previous theorems, we can give a geometrical interpretation to theorem 2.4 on the existence of generating functions. Given a canonical relation \mathcal{L} (or a Lagrangian submanifold) defined by a canonical transformation, there exists a $2n$ -dimensional (or n -dimensional) submanifold \mathcal{M} of $P_1 \times P_2$ (or P_1) such that the local projection of \mathcal{L} onto \mathcal{M} is a local diffeomorphism.

²We consider here that the generating function is function of n variables only, and has n parameters.

Study of caustics To study caustics two approaches, at least, are possible depending on the problem. A good understanding of the physics may provide information very easily. For instance, consider the two body problem in dimension 2, and the problem of going from one point A to a point B , symmetric with respect to the central body, in a certain lapse of time. The trajectory that links A to B is an ellipse whose perigee and apogee are A and B . Therefore, there are two solutions to this problem depending upon which way the particle is going. In terms of generating functions, we deduce that F_3 is nonsingular (there is a unique solution once the final momentum is given) but F_1 is singular (existence of two solutions) and the caustic is a fold³. The other method to study caustics consists in using a known nonsingular generating function to define the Lagrangian submanifold \mathcal{L} and then study its projection. A very illustrative example is given by Ehlers and Newman [6], they treat the evolution of an ensemble of free particles whose initial momentum distribution is $p = \frac{1}{1+q^2}$ using the Hamilton-Jacobi equation and generating functions for the phase flow canonical transformation. They are able to solve the problem analytically, that is, identify a time at which F_1 is singular, find the equations defining the Lagrangian submanifold using F_3 and study its projection to eventually find two folds. Nevertheless, such an analysis is not always possible as solutions to the Hamilton-Jacobi equation are usually found numerically, not analytically. In the remainder of this section, we focus on a class of problem that can be solved numerically for which we are able to characterize the caustics.

Suppose we are interested in the relative motion of a particle, called the deputy, whose coordinates are (q, p) with respect to another one, called the chief, whose coordinates are (q^0, p^0) , both moving in an Hamiltonian field. If both particles stay “close” to each other, we can expand (q, p) as a Taylor series about the trajectory of the chief. The dynamics of the relative motion is described by the Hamiltonian function H_h [9]:

$$H^h(X^h, t) = \sum_{p=2}^{\infty} \sum_{\substack{i_1, \dots, i_{2n} = 0 \\ i_1 + \dots + i_{2n} = p}}^p \frac{1}{i_1! \dots i_{2n}!} \frac{\partial^p H}{\partial q_1^{i_1} \dots \partial q_n^{i_n} \partial p_1^{i_{n+1}} \dots \partial p_n^{i_{2n}}} (q^0, p^0, t) X_1^{h i_1} \dots X_{2n}^{h i_{2n}} \quad (2.64)$$

where $X^h = (\Delta q, \Delta p)$, $\Delta q = q - q^0$ and $\Delta p = p - p^0$. Since H_h has infinitely many terms, we are usually not able to solve the Hamilton-Jacobi equation but we can approximate the dynamics by truncating the series H_h in order to only keep finitely many terms. Suppose N terms are kept, then we say that we describe the relative motion using an approximation of order N . Clearly, the

³Maps from \mathbb{R}^2 into \mathbb{R}^2 have two types of stable singularities, folds and cusps. However, only folds have two antecedents, cusps have three.

greater N is, the better our approximation is to the nonlinear motion of a particle about the nominal trajectory. When an approximation of order N is used, we look for a generating function F_{I_p, K_r} as a polynomial of order N in its spatial variables with time dependent coefficients. The Hamilton-Jacobi equation reduces to a set of ordinary differential equations that we integrate numerically. Once F_{I_p, K_r} is known, we find the other generating functions from the Legendre transformation, at the cost of a series inversion. If a generating function is singular, the inversion does not have a unique solution, the number of solutions characterizes the caustic. To illustrate this method, let us consider the following example.

Motion about the Libration point L_2 in the Hill three-body problem Consider a spacecraft moving about and staying close to the Libration point L_2 in the Hill three-body problem (See the appendix for a description of the Hill three-body problem). Its relative motion with respect to L_2 is described by the Hamiltonian function H_h (Eq. 2.64) and approximated at order N by truncation of terms of order greater than N in the Taylor series defining H_h . Using the algorithm developed by Guibout and Scheeres [9] we find the generating functions for the canonical transformation induced by the approximation of the phase flow, that is, the Taylor series expansion up to order N of the exact generating function about the Libration point L_2 .

$$\begin{aligned}
F_2(q_x, q_y, p_{0_x}, p_{0_y}, t) = & f_{11}^2(t)q_x^2 + f_{12}^2(t)q_xq_y + f_{13}^2(t)q_xp_{0_x} + f_{14}^2(t)q_xp_{0_y} \\
& f_{22}^2(t)q_y^2 + f_{23}^2(t)q_y p_{0_x}(t) + f_{24}^2(t)q_y p_{0_y} \\
& f_{33}^2(t)p_{0_x}^2 + f_{34}^2(t)p_{0_x}p_{0_y} + f_{44}^2(t)p_{0_y}^2 + r(q_x, q_y, p_{0_x}, p_{0_y}, t) \quad (2.65)
\end{aligned}$$

where (q, p, q_0, p_0) are relative position and momenta of the spacecraft with respect to L_2 at t and at t_0 , the initial time, and r is a polynomial of degree N in its spatial variables with time dependent coefficients and without any quadratic terms. At $T = 1.6822$, F_1 is singular but F_2 is not. Eqns. 2.20 and 2.21 reads:

$$p_x = 2f_{11}^2(T)q_x + f_{12}^2(T)q_y + f_{13}^2(T)p_{0_x} + f_{14}^2(T)p_{0_y} + D_1r(q_x, q_y, p_{0_x}, p_{0_y}, T) \quad (2.66)$$

$$p_y = f_{12}^2(T)q_x + 2f_{22}^2(T)q_y + f_{23}^2(T)p_{0_x} + f_{24}^2(T)p_{0_y} + D_2r(q_x, q_y, p_{0_x}, p_{0_y}, T) \quad (2.67)$$

$$q_{0_x} = f_{13}^2(T)q_x + f_{23}^2(T)q_y + 2f_{33}^2(T)p_{0_x} + f_{34}^2(T)p_{0_y} + D_3r(q_x, q_y, p_{0_x}, p_{0_y}, T) \quad (2.68)$$

$$q_{0_y} = f_{14}^2(T)q_x + f_{24}^2(T)q_y + f_{34}^2(T)p_{0_x} + 2f_{44}^2(T)p_{0_y} + D_4r(q_x, q_y, p_{0_x}, p_{0_y}, T) \quad (2.69)$$

where $D_i r$ represents the derivative of r with respect to its i^{th} variable. Eqns. 2.66-2.69 define a canonical relation \mathcal{L} . By assumption F_1 is singular, therefore the projection of \mathcal{L} onto (q, q_0) is not a local diffeomorphism and there exists a caustic. The theory developed above provides a technique to study this caustic using F_2 . Eqns. 2.66-2.69 provide p and q_0 as a function of (q, p_0) , but to characterize the caustic we need p and p_0 as a function of (q, q_0) . F_1 being singular, there are multiple solutions to this problem, and one valuable piece of information is the number k of such solutions. To find p and p_0 as a function of (q, q_0) we can first invert equations 2.68 and 2.69 to express p_0 as a function of (q, q_0) and then plug this relation into Eqns. 2.66 and 2.67. The first step requires a series inversion that can be proceeded using the technique developed in [15] by Moulton. Let us rewrite Eqns. 2.68 and 2.69:

$$2f_{33}^2(T)p_{0x} + f_{34}^2(T)p_{0y} = q_{0x} - f_{13}^2(T)q_x - f_{23}^2(T)q_y - D_3 r(q_x, q_y, p_{0x}, p_{0y}, T) \quad (2.70)$$

$$f_{34}^2(T)p_{0x} + 2f_{44}^2(T)p_{0y} = q_{0y} - f_{14}^2(T)q_x - f_{24}^2(T)q_y - D_4 r(q_x, q_y, p_{0x}, p_{0y}, T) \quad (2.71)$$

The determinant of the coefficients of the linear terms on the left hand side is zero (otherwise there is a unique solution to the series inversion) but each of the coefficients is non zero, that is, we can solve for p_{0x} as a function of (p_{0y}, q_{0x}, q_{0y}) using equation 2.70. Then we plug this solution into Eq. 2.71 and we obtain an equation of the form

$$R(p_{0y}, q_{0x}, q_{0y}) = 0 \quad (2.72)$$

that contains no terms in p_{0y} alone of the first degree. In addition, R contains a non zero term of the form αp_{0y}^2 , where α is a real number. In this case, Weierstrass proved that there exist 2 solutions p_{0y}^1 and p_{0y}^2 to Eq. 2.72, that is, the caustic is a fold.

In the same way, we can study the singularity of F_1 at initial time. At $t = 0$, F_2 generates the identity transformation, hence $f_{33}^2(0) = f_{34}^2(0) = f_{43}^2(0) = f_{44}^2(0) = 0$. This time there is no nonzero first minor, and we find that there exists infinitely many solutions to the series inversion. Another way to see this is to use the Legendre transformation:

$$F_1(q, q_0, t) = F_2(q, p_0, t) - q_0 p_0 \quad (2.73)$$

As t tends toward 0, (q, p) goes to (q_0, p_0) and F_2 converges toward the identity transformation $q p_0 \rightarrow_{t \rightarrow 0} q_0 p_0$. Therefore, as t goes to 0, F_1 also goes to 0, i.e., the projection of \mathcal{L} onto (q, q_0)

reduces to a point.

There are many other results on caustics and Lagrangian submanifolds that go beyond the scope of this paper. Study of the Lagrangian submanifold at singularities is “the beginning of deep connections between symplectic geometry, geometric optics, partial differential equations, and Fourier integral operators.” (R. Abraham [1]), we refer to Abraham [1] and references given therein for more information on this subject. Let us now come back to two-point boundary value problems.

So far we have studied the generating functions associated with the canonical transformation induced by the phase flow and showed they formally solve any two-point boundary value problem. Nonetheless, for Hamiltonian dynamical systems there exists another function, called Hamilton’s principal function, that solves the same problem and thus for completeness we discuss it. In this section we introduce this function and show how it compares to the generating functions for the canonical transformation induced by the phase flow.

2.4 Hamilton’s principal function

Though generating functions are used in this paper to solve boundary value problems, they have been introduced by Jacobi and mostly used thereafter as fundamental functions which can yield all the equations of motion by simple differentiations and eliminations, without integration. Nevertheless, it was Hamilton who first hit upon the idea of finding such a fundamental function, he proved its existence in geometrical optics (i.e., for time independent Hamiltonian systems) in 1834 and called it characteristic function [11]. The year later, he published a second essay [12] on systems of attracting and repelling points in which he showed that the evolution of dynamical systems is characterized by a single function called Hamilton’s principal function: “The former Essay contained a general method for reducing all the most important problems of dynamics to the study of one characteristic function, one central or radical relation. It was remarked at the close of that Essay, that many eliminations required by this method in its first conception, might be avoided by a general transformation, introducing the time explicitly into a part S of the whole characteristic function V ; and it is now proposed to fix the attention chiefly on this part S, and to call it the Principal Function.” (William R. Hamilton, in the introductory remarks of “Second essay on a General Method in Dynamics” [12])

2.4.1 Hamilton's principal function to describe the phase flow

As with generating functions, Hamilton's principal function may be derived using the calculus of variations. Consider the extended action integral:

$$A = \int_{\tau_0}^{\tau_1} (pq' + p_t t') d\tau \quad (2.74)$$

under the auxiliary condition $K(q, t, p, p_t) = 0$, where $q' = dq/d\tau$, p_t is the momentum associated with the generalized coordinates t and $K = p_t + H$.

Define a line element⁴ $d\sigma$ for the extended configuration space (q, t) by

$$d\sigma = Ldt = Lt' d\tau \quad (2.75)$$

Then, we can connect two points (q_0, t_0) and (q_1, t_1) of the extended configuration space by a shortest line γ and measure its length from:

$$A = \int_{\gamma} d\sigma = \int_{\gamma} Lt' d\tau \quad (2.76)$$

The distance we obtain is function of the coordinates of the end-points and is called Hamilton's principal function: $W(q_0, t_0, q_1, t_1)$.

From calculus of variations [13] we know that the variation of the action A can be expressed as a function of the boundary terms if we vary the limits of the integral:

$$\delta A = p_0 \delta q_0 + p_{t_0} \delta t_0 - p_1 \delta q_1 - p_{t_1} \delta t_1 \quad (2.77)$$

On the other hand we have:

$$\delta A = \delta W(q_0, t_0, q_1, t_1) = \frac{\partial W}{\partial q_0} \delta q_0 + \frac{\partial W}{\partial t_0} \delta t_0 + \frac{\partial W}{\partial q_1} \delta q_1 + \frac{\partial W}{\partial t_1} \delta t_1 \quad (2.78)$$

that is:

$$p_0 = \frac{\partial W}{\partial q_0}(q_0, t_0, q_1, t_1) \quad (2.79)$$

$$p_1 = -\frac{\partial W}{\partial q_1}(q_0, t_0, q_1, t_1) \quad (2.80)$$

⁴Note that the geometry established by this line element is not Riemannian [13]

and

$$\frac{\partial W}{\partial t_0}(q_0, t_0, q_1, t_1) + H(q_0, \frac{\partial W}{\partial q_0}, t_0) = 0 \quad (2.81)$$

$$-\frac{\partial W}{\partial t_1}(q_0, t_0, q_1, t_1) + H(q_1, -\frac{\partial W}{\partial q_1}, t_1) = 0 \quad (2.82)$$

where K has been replaced by $p_t + H$. As with generating functions of the first kind, Hamilton's principal function solves boundary value problems of Lambert's type through Eqns. 2.79 and 2.80. To find W , however, we need to solve a system of two partial differential equations (Eqns. 2.81 and 2.82).

2.4.2 Hamilton's principal function and generating functions

In this section we highlight the main differences between generating functions for the canonical transformation induced by the phase flow and Hamilton's principal function. For sake of simplicity we compare $F_1(q, q_0, t)$ and $W(q, t, q_0, t_0)$.

Calculus of variation Even if both functions are derived from calculus of variations, there are fundamental differences between them. To derive generating functions we used the principle of least action with the time t as independent variables whereas we increase the dimensionality of the system by adding the time t to the generalized coordinates to derive Hamilton's principal function. As a consequence, generating functions generates a transformation between two points in the phase space, i.e., they act without passage of time whereas Hamilton's principal function generates a transformation between two points in the extended phase space, i.e., between two points in the phase space with different times. This difference may be viewed as follows: Generating functions allow to characterize the phase flow given an initial time, t_0 (i.e., to characterize all trajectories whose initial conditions are specified at t_0), whereas Hamilton's principal function does not impose any constraint on the initial time. The counterpart being that Hamilton's principal function must satisfy two partial differential equations (Eq. 2.81 defines W as a function of t_0 and Eq. 2.82 defines W as a function of t_1) whereas generating functions satisfy only one.

Moreover, to derive the generating functions fixed endpoints are imposed, that is we impose the trajectory in both sets of variables to verify the principle of least action. On the other hand, the variation used to derive Hamilton's principal function involves moving endpoints and an energy constraint. This difference may be interpreted as follows: Hamilton's principal function generates a transformation which maps a point of a given energy surface to another point on the same energy

surface and is not defined for points that do not lie on this surface. As a consequence of the energy constraint we have:

$$\left| \frac{\partial^2 W}{\partial q_0 \partial q_1} \right| = 0 \quad (2.83)$$

As noticed by Lanczos [13], “this is a characteristic property of the W -function which has no equivalent in Jacobi’s theory”. On the other hand, generating functions map any point of the phase space into another one, the only constraint is imposed through the principle of least action (or equivalently by the definition of canonical transformation): we impose the trajectory in both sets of coordinates to be Hamiltonian with Hamiltonian function H and K respectively.

Fixed initial time In the derivation of Hamilton’s principal function dt_0 may be chosen to be zero, that is, the initial time is imposed. Hamilton’s principal function loses its dependence with respect to t_0 , Eq. 2.81 is trivially verified and Eq. 2.83 does not hold anymore, W and F_1 become equivalent.

Finally, in [12] Hamilton also derives another principal function $Q(p_0, t_0, p_1, t_1)$ which compares to W as F_4 compares to F_1 , the derivation being the same we will not go through it.

To conclude, Hamilton’s principal function appears to be more general than the generating functions for the canonical transformation induced by the phase flow. On the other hand, to solve a two-point boundary value problem, initial and final times are specified and therefore, any of these functions will identically solve the problem. To find Hamilton’s principal function, we need to solve two partial differential equations whereas only one need to be solved to find the generating functions. For this reason, generating functions will be used in the following examples.

3 Applications

3.1 Solving the optimal control problem using the generating functions

The use of the generating functions to solve an optimal control problem has first been addressed by Scheeres, Guibout and Park [17]. They suggested an indirect approach for evaluating the initial adjoints without initial guess. In the present paper, we review their approach and generalize it to a wider class of problem.

Problem formulation Assume a dynamical system described by:

$$\dot{x} = f(x, u, t) \quad (3.1)$$

$$x(t=0) = x_0 \quad (3.2)$$

where u is the control variable, $x \in \mathbb{R}^n$ and $u \in \mathbb{R}^m$. An optimal control problem is formulated as follows:

$$\min_u K(x(t_f)) + \int_{t_0}^{t_f} L(x, u, t) dt \quad (3.3)$$

where t_f is the known final time. This formulation is called the Bolza formulation. Other formulations are possible and completely equivalent

$$\min_u \tilde{K}(x(t_f)) \quad \text{Mayer formulation} \quad (3.4)$$

$$\min_u \int_{t_0}^{t_f} \tilde{L}(x, u, t) dt \quad \text{Lagrange formulation} \quad (3.5)$$

Further, some final conditions may be specified. For instance, suppose that k final conditions are given for the final state, i.e.,

$$\psi_j(x(t_f), t_f) = 0 \quad j \in (1 \cdots k) \quad (3.6)$$

Necessary conditions Define the Hamiltonian function H :

$$H(x, p, u, t) = p^T \dot{x} + L(x, u, t) \quad (3.7)$$

where $p \in \mathbb{R}^n$ is the costate vector. Applying the Pontryagin principle allows one to find the optimal control:

$$\bar{u} = \arg \min_u H(x, p, u, t) \quad (3.8)$$

Then the necessary conditions for optimality are given by:

$$\dot{x} = \frac{\partial H}{\partial p}(x, p, \bar{u}, t) \quad (3.9)$$

$$\dot{p} = -\frac{\partial H}{\partial x}(x, p, \bar{u}, t) \quad (3.10)$$

To integrate these $2n$ differential equations we need $2n$ boundary conditions: $n + k$ are specified in the problem statement, the other $n - k$ are given by the transversality conditions:

$$p(t_f) - \frac{\partial K}{\partial x}(t_f) = \nu^T \frac{\partial \psi}{\partial x}(x(t_f)) \quad (3.11)$$

where ν is a k -dimensional vector.

Solving the optimal control using the generating functions In the following, we are making two assumptions which may be relaxed in future research.

1. One can solve for u as a function of (x, p) using Eq. 3.8, that is, we can define a new Hamiltonian function $\bar{H}(x, p, t) = H(x, p, \bar{u}(x, p, t), t)$.
2. One can eliminate the ν 's in Eq. 3.11, so that Eq. 3.11 becomes

$$p_i(t_f) = p_{f_i} \quad \forall i \in (k, n) \quad (3.12)$$

and transform Eq. 3.6 into:

$$x_j(t_f) = x_{f_j} \quad j \in (1 \cdots k) \quad (3.13)$$

Then, solving the optimal control problem is equivalent to find the solutions (x, p) satisfying:

$$\dot{x} = \frac{\partial \bar{H}}{\partial p}(x, p, t) \quad (3.14)$$

$$\dot{p} = -\frac{\partial \bar{H}}{\partial x}(x, p, t) \quad (3.15)$$

with boundary conditions

$$\begin{aligned} x(t=0) &= x_0 \\ x_i(t_f) &= x_{f_i} \quad \forall i \in (1, \dots, k) \\ p_i(t_f) &= p_{f_i} \quad \forall i \in (k, \dots, n) \end{aligned} \quad (3.16)$$

These equations define a two-point boundary value problem and hence are usually difficult to solve because they generally require an estimate of the initial (or final) state, which usually has no physical interpretation. An indirect approach can be developed to solve this problem, namely, the use of the generating function $F_{L_n, K_k}(x_{0_1}, \dots, x_{0_n}, x_{f_1}, \dots, x_{f_k}, p_{f_{k+1}}, \dots, p_{f_n})$. Eqns. 2.15, 2.16

and 2.17 solves the boundary value problem and hence the optimal control problem:

$$p_{0_i} = -\frac{\partial F_{I_n, K_k}}{\partial x_{0_i}} \quad (3.17)$$

$$x_{f_i} = -\frac{\partial F_{I_n, K_k}}{\partial p_{f_i}} \quad (3.18)$$

$$p_{f_i} = \frac{\partial F_{I_n, K_k}}{\partial x_{f_i}} \quad (3.19)$$

In the case where $k = n$, that is initial and final states of the system are specified, the generating function that must be used to solve the boundary value problem is F_1 . In that case, Park and Scheeres [16] showed that F_1 satisfies the Hamilton-Jacobi-Bellmann equation.

Particular case: The linear quadratic problem Assume the dynamics of the system is linear:

$$\dot{x}(t) = A(t)x(t) + B(t)u(t) \quad (3.20)$$

and the cost function J is quadratic:

$$J = \frac{1}{2}[Mx(t_f) - m_f]^T Q_f [Mx(t_f) - m_f] + \frac{1}{2} \int_{t_0}^{t_f} \begin{pmatrix} x^T & u^T \end{pmatrix} \begin{pmatrix} Q & N \\ N^T & R \end{pmatrix} \begin{pmatrix} x \\ u \end{pmatrix} \quad (3.21)$$

and Q is symmetric positive semi-definite, R and Q_f are symmetric positive definite. Moreover, define L to be $L = \frac{1}{2} \begin{pmatrix} x^T & u^T \end{pmatrix} \begin{pmatrix} Q & N \\ N^T & R \end{pmatrix} \begin{pmatrix} x \\ u \end{pmatrix}$

Using previous notations, we define the Hamiltonian function H :

$$H(x, p, u) = p^T \dot{x} + L(x, u) \quad (3.22)$$

From equation 3.8, we get

$$\bar{u} = -R^{-1}B^T p - R^{-1}N^T x \quad (3.23)$$

Substituting \bar{u} in Eqns. 3.9 and 3.10 yields:

$$\bar{H}(x, p) = H(x, p, -R^{-1}B^T p - R^{-1}N^T x) \quad (3.24)$$

and

$$\dot{x} = Ax + B(-R^{-1}B^T p - R^{-1}N^T x) \quad (3.25)$$

$$\dot{p} = -(A^T p + Qx + N(-R^{-T}B^T p - R^{-1}N^T x)) \quad (3.26)$$

Boundary conditions for this problem are still given by equations 3.16. Since the Hamiltonian function defining this system is quadratic, this problem is often solved using the state transition matrix. We have seen previously that, in linear systems theory, both generating functions and the state transition matrix are equivalent. Moreover, to compute the generating function or the state transition matrix, four matrix equations of dimension n need to be solved. Therefore, both methods are exactly equivalent for the linear quadratic problem. Finally, another method to solve the linear quadratic problem is to apply Ricatti transformation to reduce the problem to two matrix ordinary differential equations, a Ricatti equation and a time-varying linear equation. An analogy can be drawn between these two equations and the ones verified by the generating function.

3.2 Finding periodic orbits using the generating functions

Another application of the generating functions for the canonical transformation induced by the phase flow is to search for periodic orbits. This application was first presented by Guibout and Scheeres [10], we review their methodology in this paper and refer to [10] for more details and additional examples.

3.2.1 The search for periodic orbits: a two-point boundary value problem

The main idea is to transform the search for periodic orbits into a two-point boundary value problem that can be handled using generating functions. For a periodic orbit of period T , both position and momentum take the same values at t and at $t + kT$, $k \in \mathbb{Z}$. In terms of initial conditions, this reads:

$$q(T) = q_0 \quad (3.27)$$

$$p(T) = p_0 \quad (3.28)$$

For a dynamical system with n degrees of freedom Eqns. 3.27 and 3.28 can be viewed as $2n$ equations of $2n + 1$ variables, the initial conditions (q_0, p_0) and the period T . To solve such a problem, for each trial (q_0, p_0, T) one needs to integrate the equations of motion and check if the

$2n$ equations are verified, and if they are not try again. On the other hand, Eqns. 3.27 and 3.28 can also be viewed as a two-point boundary value problem. Suppose the initial momentum p_0 and the position at time T , q , are given, then Eqns. 3.27 and 3.28 define $2n$ equations with $2n + 1$ variables, the initial position q_0 , the momentum at time T , p , and the time period T . Solutions to these equations characterize all periodic orbits. The idea now is to use the generating functions for the phase flow transformation to solve this problem. Depending on the two-point boundary value problem we choose to characterize periodic orbits, different generating functions can be used. In the following we will only deal with generating functions of the first and second kind, but this theory can be readily generalized to any kind of generating functions.

3.2.2 Solving the two-point boundary value problem

Generating functions of the first kind The generating function F_1 allows us to solve a two-point boundary value problem for which initial position and position at time T are given. The solution to this problem is found using Eqns. 2.8 and 2.9.

$$p = \frac{\partial F_1}{\partial q}(q, q_0, T) \quad (3.29)$$

$$p_0 = -\frac{\partial F_1}{\partial q_0}(q, q_0, T) \quad (3.30)$$

On the other hand, the boundary value problem that characterizes periodic orbits is defined by equations 3.27 and 3.28. Hence, combining these four equations yields:

$$p_0 = -\frac{\partial F_1}{\partial q_0}(q = q_0, q_0, T) \quad (3.31)$$

$$p(T) = \frac{\partial F_1}{\partial q}(q = q_0, q_0, T) \quad (3.32)$$

That is, since $p(T) = p_0$:

$$\frac{\partial F_1}{\partial q}(q = q_0, q_0, T) + \frac{\partial F_1}{\partial q_0}(q = q_0, q_0, T) = 0 \quad (3.33)$$

Eq. 3.33 defines n equations with $n + 1$ variables, (q_0, T) , it is an under-determined system, and hence we often focus on one of the two following problems:

1. *Search in time domain*: Given a point in the position space q_0 , find all periodic orbits going through this point and their associated momentum. Eq. 3.33 defines n equations of a single

variable T . Taking the norm of the left hand side yields:

$$\left\| \frac{\partial F_1}{\partial q}(q = q_0, q_0, T) + \frac{\partial F_1}{\partial q_0}(q = q_0, q_0, T) \right\| = 0 \quad (3.34)$$

Eq. 3.34 is a single equation of one variable that can be solved graphically. To find the corresponding momentum, we can use either Eq. 2.20 or Eq. 2.21:

$$p_0 = -\frac{\partial F_1}{\partial q_0}(q = q_0, q_0, T) \quad (3.35)$$

$$p = \frac{\partial F_1}{\partial q}(q = q_0, q_0, T) \quad (3.36)$$

Both equations provide the same momentum since Eq. 3.34 is equivalent to $\|p - p_0\| = 0$ and is satisfied.

2. *Search in position space:* Find all periodic orbits of a given period. Eq. 3.33 reduces to a system of n equations with n unknowns, q_0 . For dynamical systems with n degrees of freedom the solution may be represented on a n -dimensional plot. In practice, solving this problem graphically is efficient only for systems with at most 3 degrees of freedom. For Hamiltonian systems with more than 3 degrees of freedom, Newton iteration or an equivalent method can be used. When a solution to Eq. 3.33 is obtained, then we use Eq. 2.8 or 2.9 to find the corresponding momentum:

$$p_0 = -\frac{\partial F_1}{\partial q_0}(q = q_0, q_0, T) \quad (3.37)$$

$$p = \frac{\partial F_1}{\partial q}(q = q_0, q_0, T) \quad (3.38)$$

Generating function of the second kind The search for periodic orbits can also be solved using a generating function of the second kind. The main difference with the use of F_1 is that the system of equations we need to solve does not reduce to a system of n equations and n functions evaluations (we must solve $2n$ equations).

The generating function F_2 allows us to solve a two-point boundary value problem for which the initial momentum and the position at time T are given. The solution to this problem is found using

Eqns. 2.20 and 2.21.

$$p = \frac{\partial F_2}{\partial q}(q, p_0, T) \quad (3.39)$$

$$q_0 = \frac{\partial F_2}{\partial p_0}(q, p_0, T) \quad (3.40)$$

On the other hand, the boundary value problem is defined by equations 3.27 and 3.28. Combining these four equations yields:

$$\begin{aligned} p_0 &= p(T) \\ &= \frac{\partial F_2}{\partial q}(q, p_0, T) \end{aligned} \quad (3.41)$$

$$\begin{aligned} q(T) &= q_0 \\ &= \frac{\partial F_2}{\partial p_0}(q, p_0, T) \end{aligned} \quad (3.42)$$

The system of equations 3.41 and 3.42 contains $2n$ equations with $2n + 1$ variables, and therefore is under-determined. As with F_1 , we consider two main problems, we either set the time period or n coordinates of the point in the phase space.

3.2.3 Examples

To illustrate the theory developed above, let us consider the Hill three-body problem and let us find periodic orbits about the Libration point L_2 using the generating function of the first kind F_1 . To compute F_1 , we use the algorithm developed by Guibout and Scheeres [9] that computes the Taylor series expansion of the generating functions about a given trajectory, called the reference trajectory. In this example the reference trajectory is the equilibrium point L_2 and we compute the Taylor series up to order 6. Since we are working with series expansion, we will only find periodic orbits that stay within the radius of convergence of the series, not all periodic orbits.

Search in time domain: Find all periodic orbits going through the point⁵ $(0.01, 0)$. We have seen that this problem can be handled using Eq. 3.34 which is one equation with one variable, T . In Figure 1 we have plotted the left-hand side of Eq. 3.34 as a function of time, we obtain a continuous curve whose points have a particular significance. Let x be a point on that curve whose coordinates are $x = (t_x, \Delta p)$. The trajectory whose initial conditions are $q_0 = (0.01, 0)$, $p_0 = -\frac{\partial F_1}{\partial q_0}(q_0, q_0, t_x)$ comes back to its initial position after a time t_x but the norm of the difference between its initial

⁵We use normalized units, for the Sun-Earth-spacecraft system 0.01 units of length represents about 21,500km

momentum and its momentum at time t_x is Δp . Hence, any point on the curve whose coordinates are $(t_x, 0)$ represents a periodic orbit (not only the trajectory comes back to its initial position at t_x but the norm of the difference between the momenta at initial time and at t_x is zero, i.e., the trajectory comes back to its initial state at t_x). In figure 1, we observe that there exists a periodic orbit of period $T = 3.03353$ going through the point $(0.01, 0)$. The corresponding momenta is found using either Eq. 2.20 or Eq. 2.21 and is $p_0 = p = (0, -0.0573157)$.

Search in position space: Find all periodic orbits of period $T = 3.0345$. To solve this problem we use Eq. 3.33, which is a system of two equations with two variables (q_{0_x}, q_{0_y}) . In Fig. 2 we plot solutions to each of these two equations and then superimpose them to find their intersection, which is the solution to Eq. 3.33. The solution is a closed curve, i.e., a periodic orbit of the given period. By plotting the solutions to Eq. 3.33 for different periods, we generate a map of a family of periodic orbits around the Libration point. In Figure 3 we plot the solutions to Eq. 3.33 for $t = 3.033 + 0.0005n$, $n \in \{0, \dots, 9\}$.

3.3 Study of equilibrium points

The generating functions can also be used to study properties of equilibrium points of an Hamiltonian dynamical system. First, we have proved the equivalence between the state transition matrix and the generating functions describing relative motion in linear system theory, therefore, linear terms in the Taylor series expansion of the generating functions about the equilibrium point provide information on the characteristic time and stability as does the state transition matrix. The other terms can be used to study the geometry of center, stable and unstable manifolds far from the equilibrium points where the linear approximation does not hold anymore (but within the radius of convergence of the Taylor series). The study of center manifolds is a direct application of the previous section as is readily seen from the example we provided. To find stable and unstable manifolds we propose a technique that uses generating functions to solve initial value problems, not two-point boundary value problems. Historically, generating functions were introduced by Jacobi and used thereafter to solve initial value problems, hence the following technique is not new. We mention it to show that one is able to fully describe an equilibrium point with only knowledge of the generating functions.

The idea is to propagate the trajectory of a point that is “close” to the equilibrium point and on the linear approximation of the stable (unstable) manifold. Even though this method to find unstable and stable manifolds is not exact, it is fairly accurate and often used. We then reduce the

search for hyperbolic manifolds to an initial value problem that can be solved using any generating functions. For simplicity let us consider F_2 . At the linear level, a point on the unstable (stable) manifold has coordinates $(q_0, p_0) = (\alpha\hat{u}, \alpha\lambda\hat{u})$ where $\alpha \ll 1$, λ is the characteristic exponent and \hat{u} is the eigenvector defining the unstable (stable) manifold. Eq. 2.21 defines $q(t)$ implicitly:

$$\alpha\hat{u} = q_0 = \frac{\partial F_2}{\partial p_0}(q, \alpha\lambda\hat{u}, t)$$

Once $q(t)$ is found, we find $p(t)$ from Eq. 2.20. As t varies, $(q(t), p(t))$ describes the hyperbolic manifolds.

3.4 Design of spacecraft formation trajectories

The last application we present concerns the design of a formation of spacecraft. This is again a direct application of the theory developed in this paper, first introduced by Guibout and Scheeres [9]. This application relies on the fact that the relative dynamics of two particles evolving in a Hamiltonian dynamical system is Hamiltonian, hence the Hamilton-Jacobi theory is applicable. To illustrate the use of generating functions, let us study an example. We consider a constellation of spacecraft located at the Libration point L_2 of Hill's three-body problem. At a later time $t = t_f$, we want the spacecraft to lie on a circle surrounding the libration point at a distance of 108,000km. What initial velocity is required to transfer to this circle in time t_f , and what will the final velocity be once we arrive at the circle? The answer will depend, of course, on where we arrive on the circle. In general, this problem must be solved repeatedly for each point on the circle we wish to transfer to and each transfer time. In our example we only need to compute the generating functions F_1 to be able to compute the answer as an analytic function of the final location. The method to solve this problem proceeds as follows: We first compute F_1 then we compute the solution to the problem of transferring from L_2 to a point on the final circle where 2 parameters may vary, the transfer time and the location on the circle. Then we look at solutions which minimize the total fuel cost of the maneuver, that is, which minimize the sum of the norm of the initial momentum and the norm of the final momentum, $\sqrt{|\Delta p_0|^2 + |\Delta p|^2}$. We assume zero momentum in the Hill's rotating frame at the beginning and end of the maneuver. While not a realistic maneuver, we can use it to exhibit the applicability of our approach.

Figures 4, 5 and 6 show the value of $\sqrt{|\Delta p_0|^2 + |\Delta p|^2}$ as a function of position in the final formation at different times ⁶. We notice three tendencies:

⁶Define the final position of the spacecraft as $\Delta q = \Delta q \hat{q}$ where $\Delta q = 108,000km$ and \hat{q} is the unit vector pointing

1. For t less than the characteristic time, no matter which direction the spacecraft leaves L_2 , it costs essentially the same amount of fuel to reach the final position and stop (figure 4).
2. For t larger than the characteristic time, but less than 47 days the curve describing $\sqrt{|\Delta p_0|^2 + |\Delta p|^2}$ shrinks along a direction 80° from the x -direction. Thus, placing a spacecraft on the final circle at an angle of 80° or 260° from the x -axis provides the lowest cost in fuel (figure 5).
3. For t larger than 47 days, the curve describing $\sqrt{|\Delta p_0|^2 + |\Delta p|^2}$ shrinks along a direction perpendicular to the previous one, at an angle of $\sim 170^\circ$ with the x -axis and expands along the 80° direction. Thus, there exists an epoch for which placing a spacecraft on the final circle at an angle of 170° or 350° from the x -axis provides the lowest final cost, this happens for $t = 88$ days (figures 5 and 6).

To conclude, we see the optimal transfer time to the final circle changes as a function of location on the circle. While this is to be expected, our results provide direct solutions for this non-linear boundary value problem.

We now make a few additional remarks to emphasize the advantage of our method. First, additional spacecraft do not require any additional computations. Hence, our method to design optimal reconfiguration is valid for infinitely many spacecraft in formation. Second, now that we have computed the generating functions around the libration point, we are able to analyze any reconfiguration around the libration point at the cost of evaluating a polynomial function⁷. Finally, if the formation of spacecraft is evolving around a base which is on a given trajectory, we can linearize about this trajectory, and then proceed as in the above examples to study the reconfiguration problem.

Conclusions

This paper describes a novel application of Hamilton-Jacobi theory. We are able to formally solve any nonlinear two-point boundary value problem using generating functions for the canonical transformation induced by the phase flow. Many applications of this method are possible, and we have introduced a few of them, and implemented them successfully. Nevertheless, the method we

towards the location of the final circle. Then, figures 4-6 represent $\sqrt{|\Delta p_0|^2 + |\Delta p|^2} \hat{q}$

⁷This is especially valuable for missions involving spacecraft that stay close to L_2 since the generating functions in this region can be computed during mission planning. Then any targeting problem or reconfiguration design can be achieved at the cost of a function evaluation

propose is based on our ability to obtain generating functions, that is to solve the Hamilton-Jacobi equation. In general such a solution cannot be found, but for a certain class of problem an algorithm has been developed [9] that converges locally in phase space. A typical use of this algorithm would be to study the optimal control problem about a known trajectory, to find families of periodic orbits about an equilibrium point or in the vicinity of another periodic orbit, and to study spacecraft formation trajectories.

Appendix I: The circular restricted three-body problem and Hill's three-body problem

The circular restricted three-body problem is a three-body problem where the second body is in circular orbit about the first one and the third body has negligible mass [3]. The coordinate system is centered at the center of mass of the two bodies with mass and the Hamiltonian function describing the dynamics of the third body is:

$$H(q_x, q_y, p_x, p_y) = \frac{1}{2}(p_x^2 + p_y^2) + p_x q_y - q_x p_y - \frac{1-\mu}{\sqrt{(q_x + \mu)^2 + q_y^2}} - \frac{\mu}{\sqrt{(q_x - 1 + \mu)^2 + q_y^2}} \quad (3.43)$$

where $q_x = x$, $q_y = y$, $p_x = \dot{x} - y$ and $p_y = \dot{y} + x$. Equations of motion for the third body can be found from Hamilton's equations:

$$\ddot{x} - 2\dot{y} = x - (1-\mu) \frac{x + \mu}{((q_x + \mu)^2 + q_y^2)^{3/2}} - \mu \frac{x - 1 + \mu}{((q_x - 1 + \mu)^2 + q_y^2)^{3/2}} \quad (3.44)$$

$$\ddot{y} + 2\dot{x} = y - (1-\mu) \frac{y}{((q_x + \mu)^2 + q_y^2)^{3/2}} - \mu \frac{y}{((q_x - 1 + \mu)^2 + q_y^2)^{3/2}} \quad (3.45)$$

There are five equilibrium points for this system, called the Libration points. L_2 is the one whose coordinates are $(1.01007, 0)$ for a value of $\mu = 3.03591 \cdot 10^{-6}$.

If the first body has a larger mass than the second one we can expand the equations of motion about $\mu = 0$. Then, shifting the coordinate system so that its center is the second body yields Hill's

formulation of the three-body problem. The equations are motion are:

$$\ddot{x} - 2\dot{y} = -\frac{x}{r^3} + 3x \quad (3.46)$$

$$\ddot{y} + 2\dot{x} = -\frac{y}{r^3} \quad (3.47)$$

$$(3.48)$$

where $r^2 = x^2 + y^2$.

The Lagrangian then reads:

$$L(q, \dot{q}, t) = \frac{1}{2}(\dot{q}_x^2 + \dot{q}_y^2) + \frac{1}{\sqrt{q_x^2 + q_y^2}} + \frac{3}{2}q_x^2 - (\dot{q}_x q_y - \dot{q}_y q_x) \quad (3.49)$$

Hence,

$$\begin{aligned} p_x &= \frac{\partial L}{\partial \dot{q}_x} \\ &= \dot{q}_x - q_y \end{aligned} \quad (3.50)$$

$$\begin{aligned} p_y &= \frac{\partial L}{\partial \dot{q}_y} \\ &= \dot{q}_y + q_x \end{aligned} \quad (3.51)$$

From Eqns. 3.49, 3.50 and 3.51 we obtain the Hamiltonian function H :

$$\begin{aligned} H(q, p) &= p_x \dot{q}_x + p_y \dot{q}_y - L \\ &= \frac{1}{2}(p_x^2 + p_y^2) + (q_y p_x - q_x p_y) - \frac{1}{\sqrt{q_x^2 + q_y^2}} + \frac{1}{2}(q_y^2 - 2q_x^2) \end{aligned} \quad (3.52)$$

There are two equilibrium points for this system, called libration points. Their coordinates are $L_1(-(\frac{1}{3})^{1/3}, 0)$ and $L_2((\frac{1}{3})^{1/3}, 0)$

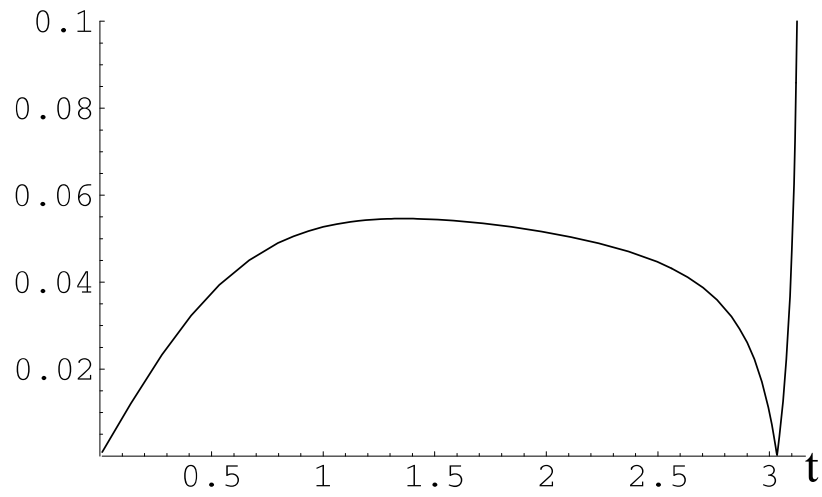
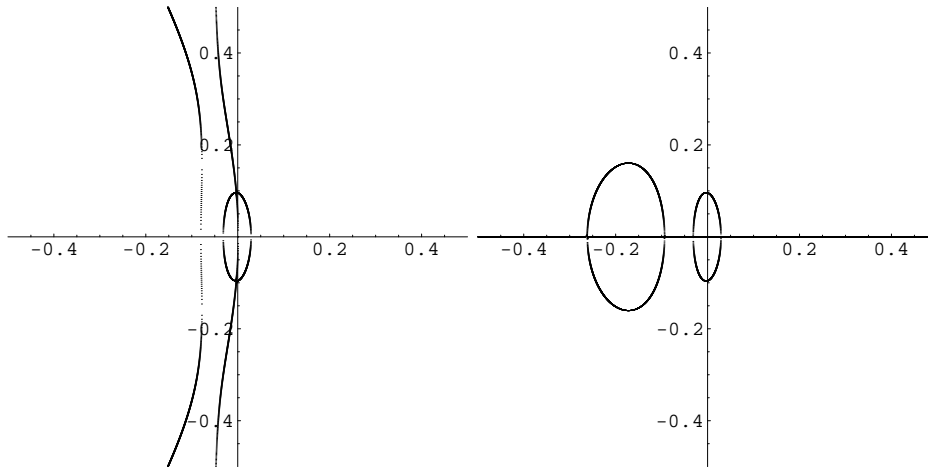
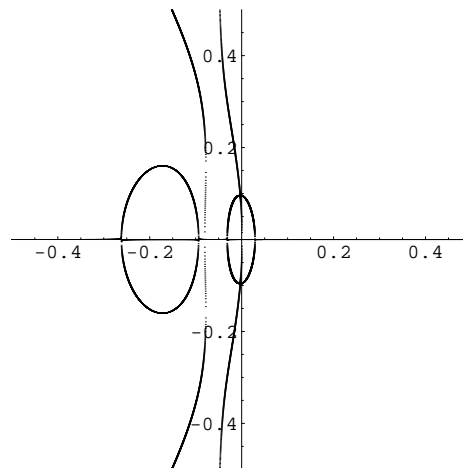

Figure 1: Plot of $\|\frac{\partial F_1}{\partial q}(q = q_0, q_0, T) + \frac{\partial F_1}{\partial q_0}(q = q_0, q_0, T)\|$ where $q_0 = (0.01, 0)$



(a) Plot of the solution to the first equation defined by Eq. 3.33

(b) Plot of the solution to the second equation defined by Eq. 3.33



(c) Superposition of the two sets of solutions

Figure 2: Periodic orbits for the nonlinear motion about a Libration point

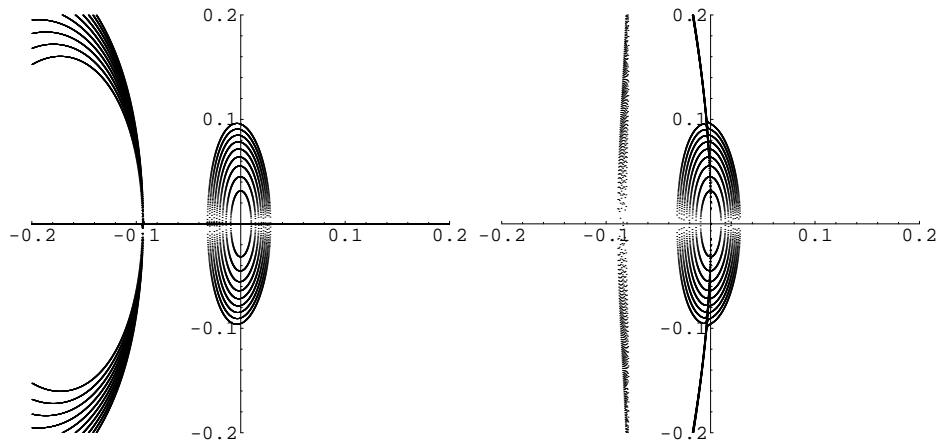

(a) Plot of the solution to the first equation defined by Eq. 3.33 for $t = 3.033 + 0.0005n$ $n \in \{1 \cdots 10\}$

(b) Plot of the solution to the second equation defined by Eq. 3.33 for $t = 3.033 + 0.0005n$ $n \in \{1 \cdots 10\}$

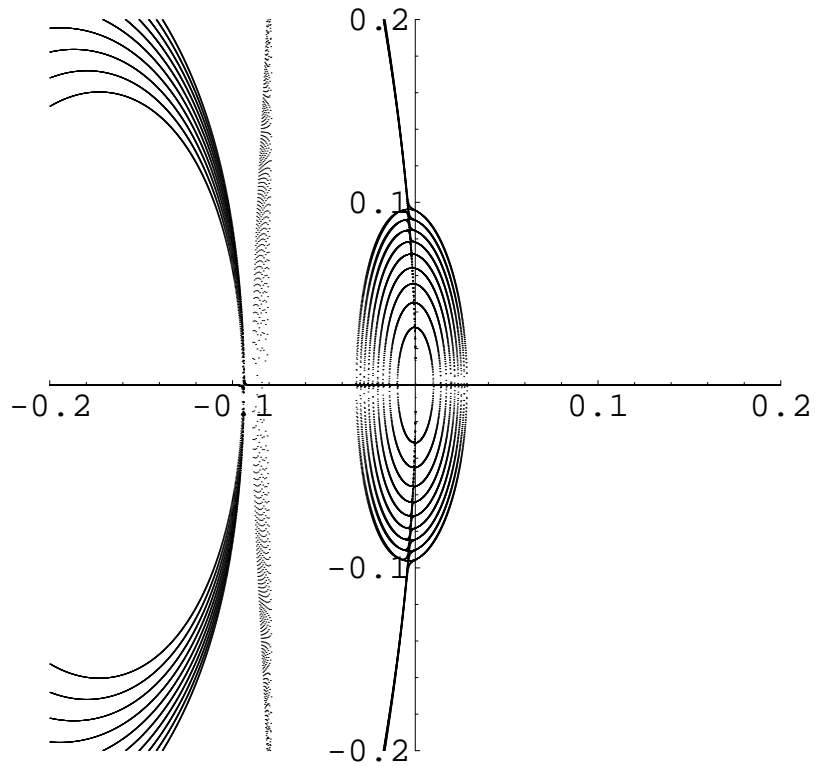

(c) Superposition of the two sets of solutions for $t = 3.033 + 0.0005n$ $n \in \{1 \cdots 10\}$

Figure 3: Periodic orbits for the nonlinear motion about a Libration point

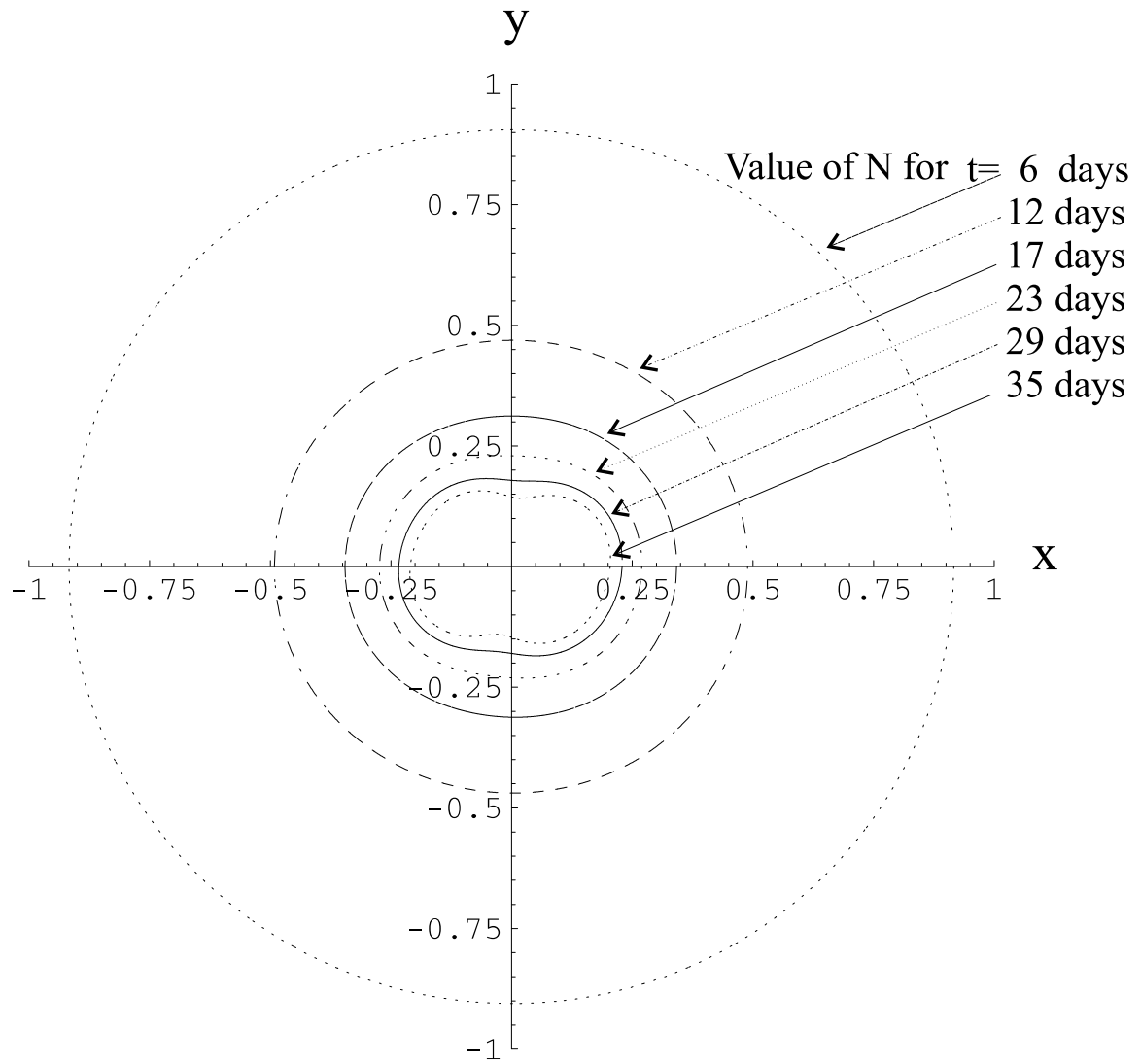

Figure 4: $\sqrt{|\Delta p_0|^2 + |\Delta p|^2} \hat{q}$ for $t \in [6days, 35days]$
 $1unit \longleftrightarrow 432m.s^{-1}$

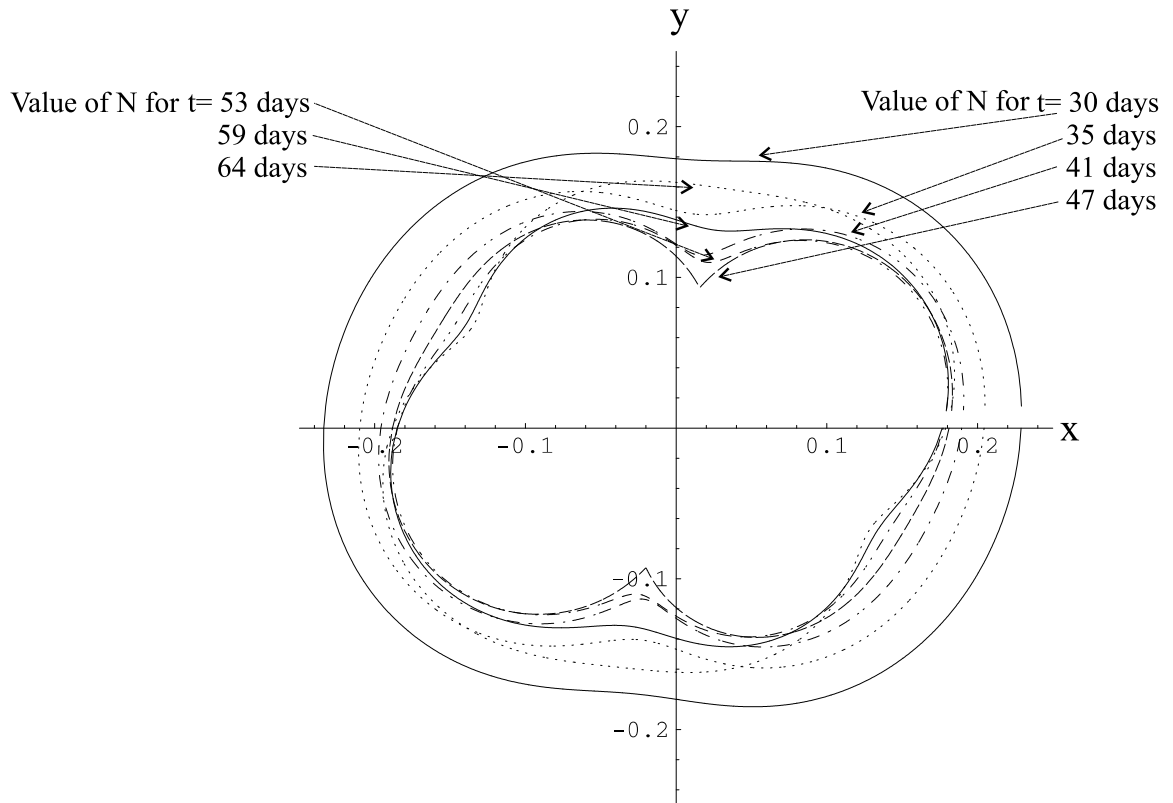

Figure 5: $\sqrt{|\Delta p_0|^2 + |\Delta p|^2} \hat{q}$ for $t \in [30 \text{ days}, 64 \text{ days}]$
 $1 \text{ unit} \longleftrightarrow 432 \text{ m.s}^{-1}$

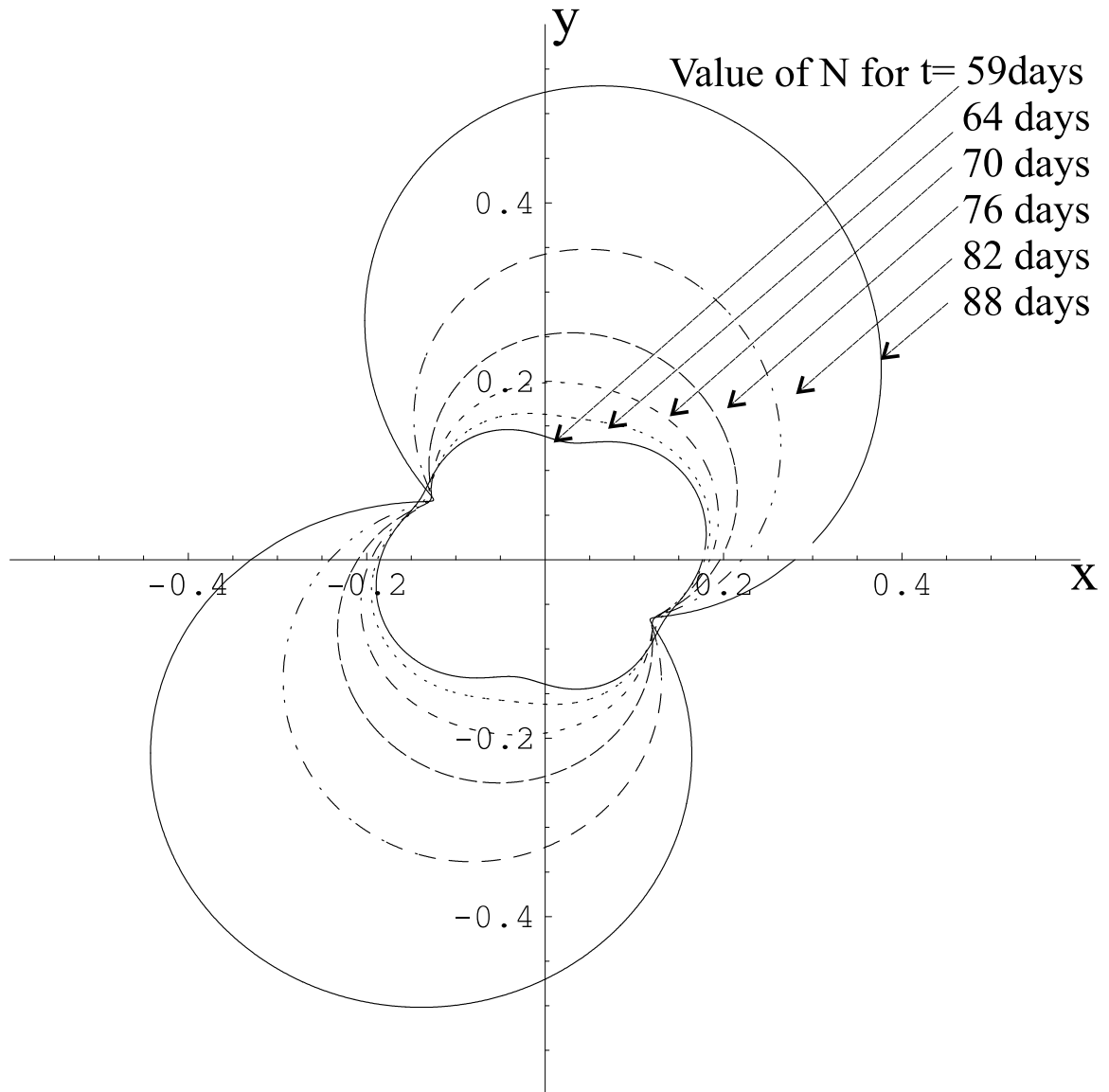

Figure 6: $\sqrt{|\Delta p_0|^2 + |\Delta p|^2} \hat{q}$ for $t \in [59days, 88days]$
 $1unit \longleftrightarrow 432m.s^{-1}$

References

- [1] Ralph Abraham and Jerrold E. Marsden. *Foundations of mechanics*. W. A. Benjamin, 2nd edition, 1978.
- [2] Vladimir I. Arnold. *Mathematical Methods of Classical Mechanics*. Springer-Verlag, 2nd edition, 1988.
- [3] Vladimir I. Arnold, V. V. Kozlov, and A. I. Neishtadt. *Mathematical Aspects of Classical and Celestial Mechanics, Dynamical Systems III*. Springer-Verlag, 1988.
- [4] Richard H. Battin. *An Introduction to the Mathematics and Methods of Astrodynamics*. American Institute of Aeronautics and Astronautics, revised edition, 1999.
- [5] Peter Colwell. *Solving Kepler's equation over three centuries*. Richmond, Va. : Willmann-Bell, 1993.
- [6] Juergen Ehlers and Ezra T. Newman. The theory of caustics and wavefront singularities with physical applications. *Journal of Mathematical Physics A*, 41(6):3344–3378, 2000.
- [7] Herbert Goldstein. *Classical Mechanics*. Addison-Wesley, 1965.
- [8] Donald T Greenwood. *Classical Dynamics*. Prentice-Hall, 1977.
- [9] Vincent M. Guibout and Daniel J. Scheeres. Formation flight with generating functions: Solving the relative boundary value problem. In *AIAA/AAS Astrodynamics Specialist Conference and Exhibit, Monterey, California. Paper AIAA 2002-4639*. AIAA, 2002.
- [10] Vincent M. Guibout and Daniel J. Scheeres. Periodic orbits from generating functions. In *AAS/AIAA Astrodynamics Specialist Conference and Exhibit, Big Sky, Montana. Paper AAS 03-566*. AAS, 2003.
- [11] William Rowan Hamilton. On a general method in dynamics. *Philosophical Transactions of the Royal Society, Part II*, pages 247–308, 1834.
- [12] William Rowan Hamilton. Second essay on a general method in dynamics. *Philosophical Transactions of the Royal Society, Part I*, pages 95–144, 1835.
- [13] Cornelius Lanczos. *The variational principles of mechanics*. University of Toronto Press, 4th edition, 1977.

- [14] Jerrold E. Marsden and Tudor S. Ratiu. *Introduction to mechanics and symmetry : a basic exposition of classical mechanical systems*. Springer-Verlag, 2nd edition, 1998.
- [15] Forest R. Moulton. *Differential equations*. The Macmillan company, 1930.
- [16] C. Park and Daniel J. Scheeres. Indirect solutions of the optimal feedback control using hamiltonian dynamics and generating functions. In *Proceedings of the 2003 IEEE conference on Decision and Control, accepted, 2003. Maui, Hawaii*. IEEE, 2003.
- [17] Daniel J. Scheeres, Vincent M. Guibout, and C. Park. Solving optimal control problems with generating functions. In *AAS/AIAA Astrodynamics Specialist Conference and Exhibit, Big Sky, Montana. Paper AAS 03-575*. AAS, 2003.
- [18] P. K. C. Wang and F. Y. Hadaegh. Minimum-fuel formation reconfiguration of multiple free-flying spacecraft. *The Journal of the Astronautical Sciences*, 47(1-2):77–102, 1999.
- [19] Alain Weinstein. Lectures on symplectic manifolds. *Regional conference series in mathematics*, 29, 1977.